

MANAGEMENT OF COMBINED SEWER OVERFLOWS

Rob Baker

Abstract

Combined sewer overflow (CSO) events are an unintended consequence that pollutes surface receiving waters in the United States with excess and unnatural amounts of BOD, suspended solids, sediments, pathogens, and toxic substances. Many techniques to minimize, and in many cases eliminate, CSO volumes from being released to surface water outfalls have been implemented. Those discussed in this paper include sewer separation, storage and slow release of storm water volumes into combined sewers, minimizing the flow and solids entering the combined sewers during storm events, and the use of wet weather treatment facilities. No single solution is the answer for all communities with combined sewers, but there is no reason why CSO events cannot be minimized given the options available.

Keywords: Combined sewer systems, combined sewer overflow (CSO), sewer separation, flow redirection, flow slipping, retention basins, infiltration sumps, vortex or swirl technology, wet weather treatment facilities.

Introduction

Combined sewer systems carry both storm water and sanitary sewage in one pipe. Most of the systems in the United States were built many decades ago and when the intent was to save money and material by serving two conveyance needs with one set of pipes. These systems are common in the Northeast and Great Lakes Regions, but are not exclusive to those areas as Atlanta, Georgia and Portland, Oregon have them as well. According to the Environmental Protection Agency (EPA), over 1000 exist in the United States (EPA 832-F-99-041, 1999). However, as cities expanded with more infrastructure, the good intentions of combined sewer design produced serious concerns to surface water quality.

The bad consequence of combined sewer systems is the combined sewer overflow (CSO). The combined sewer systems were designed to serve the average daily and peak sanitary flows and moderate rainfall events. If the pipes were big enough to handle the largest rainfall on record, then the pipes would be too big to adequately convey the sanitary flows during periods of no rain unless high slopes were involved. The particulate solids from normal to low sanitary flows would not be carried to the municipal wastewater treatment plant because they would settle and remain at the bottom of the oversized pipes. Pipes that are

not fully flushed develop slime layers of bacteria around the sides that lead to reduced efficiency and anaerobic conditions. These conditions contribute to hydrogen sulfide production in the pipes (Maier et al., 2000). On the other hand, if the pipes were designed for sanitary flows only, many rainfall events would overflow the system. During the early days of these systems, the result of a CSO would cause untreated sewage and storm water to back up into resident's basements and onto to streets from manholes and drains.

The initial solution to the problem of overflow into resident's basements and onto their streets was to redirect the untreated sewage and storm water to a combined sewer outfall – a location that would not bother any of the city's residents. As long as the problem was out of sight for the majority of the residents, it was not a problem. Additional support came from the thinking that the large volume of storm water would dilute the sanitary sewage to a great extent and no significant pollution problems would result. This thinking was prior to the enactment of legislation like the Clean Water Act of 1972 and the Resource Conservation and Recovery Act of 1976. Afterwards, release of untreated wastewater and hazardous substances, diluted or not, was no longer acceptable under the law.

The combined systems serving cities like Minneapolis, Boston, Portland, and Atlanta had grown to serve bigger populations, more residences, and more streets so the volume of wastewater released became bigger as well. The wastewater may be diluted with storm water, but it still has pollutants in it. A CSO event releases the following constituents of concern to the surface water environment:

- Pathogens
- Heavy metals
- Sediment from the streets
- Suspended solids from sanitary flows
- BOD
- Nutrients (nitrogen and phosphorus compounds)
- Oils and grease
- Floating debris
- Pesticides and herbicides from lawn and horticultural activities

These constituents would normally be treated to an acceptable level by a wastewater treatment plant if the overflow event did not occur. When it does, the release of these constituents does not promote a natural environment for aquatic species and fauna to live in and may present a risk to human activities in the water body. This unnatural situation violates the Clean Water Act. In addition, aesthetic issues resulting from bad smells and unnatural looking surface bodies result at a CSO outfall as well. As will be shown in this paper, significant action and monetary resources were needed to minimize and eliminate CSO events from occurring for many cities in the U.S.

The EPA and State Departments of Natural Resources levy fines and other penalties to those municipalities that are not in compliance with the regulations. The ideal solution is to remove the combined sewer systems and replace them with separate systems – one for sanitary flows and one for storm water flows. In theory, this solution gets to the very root of the design problem. However, it has also proven to be the most expensive and the most difficult to implement. Other solutions that fall short of total separation and replacement have been implemented and prevented CSO events from occurring. Combinations of these options provide good alternatives for those cities where residents will not approve a municipal bond measure to spend millions on sewer separation. Many residents favor spending money and effort on more budget items that they can see the direct results of - like reducing crime, improving schools, repaving roads, building community centers, and hosting festivals. Rebuilding a sewer system that is more responsible to the environment and to the neighboring towns downstream of their outfalls is a difficult sell.

This paper seeks to describe and discuss the solutions being implemented in the United States to prevent CSO events. The first solution is sewer separation. Facts from case studies of cities that implemented this solution as a whole or in part will be presented. Next, the improvement of existing combined sewer systems with innovative technologies will be discussed. No one solution is the best for all cities. Criteria such as cost, compatibility with the available technology, and tolerance of the community for aesthetic problems will be applied to the solutions. No one solution applies to every city, but combinations of solutions often prevent future CSO events from occurring.

Combined Sewer Separation

Given a large enough rainfall event, all combined sewers will lead to CSO problems because the system possesses a flaw in design from the start. The best solution for stopping CSO events from occurring is by sewer separation. If all of the sanitary flows reach the wastewater treatment plant, then the pollutant sources coming from the sanitary flows will not be present in the storm water. A storm water system that does not have to treat sanitary pollutants can be more efficiently designed and operated. Storm water volumes can be stored longer before becoming septic. Manholes, flow control devices, and retention basins require much less maintenance with less solids load going into them. With regard to the sanitary system, when contaminant concentrations in the sanitary flow are consistent (not being diluted during storm events), the biological treatment processes at the wastewater treatment plants can be optimized more effectively. So why is it that all cities don't employ sewer separation?

Of all the solutions discussed in this review, sewer separation is the costliest, requires the most construction, and creates the most inconvenience for the affected city residents. In a sewer separation project in St. Paul, Minnesota, workers installed 189 miles of storm sewers and 11.9 miles of sanitary sewers

covering a drainage area of 21,000 acres by 1996 (EPA 832-F-99-041, 1999). The costs ranged from \$8350 to \$43,060 per acre, but averaged \$15,400 per acre (1984 dollars). One of the main reasons for the variability in cost was that the sewer separation was combined with other infrastructure improvements like pavement replacement, repair and replacement of water and natural gas lines, sidewalk installation, and street lights replacement. The issues prior to sewer separation were sanitary sewage back-ups in homes, street flooding and sorely needed replacement of existing sewer lines. The City of Portland, Oregon completed a sewer replacement at \$18,000 an acre and the unit cost for Detroit, Michigan was \$67,800 per acre. (The reference, EPA 832-F-99-041, was not clear on when the projects Detroit and Portland projects occurred).

The EPA fact sheet on sewer separation points out some significant disadvantages to sewer separation. First, installing new sewer lines is a major endeavor in construction. Many combined sewer lines lay below streets within the right-of-way of the road. Heavy equipment required for sewer pipe excavation and installation will delay, redirect, and stop street traffic. Construction sites become dirty and dusty and impact the property owners and users of the street. In addition, businesses may be adversely impacted by a prolonged construction site at their front door. In addition, alternative routing of storm and sanitary flows around the construction site needs to be done. Environmental mitigations for the construction will need to be implemented. Due to these challenges, residents and businesses may push for solutions other than sewer separation.

Sewer separation has been implemented by using the existing combined sewer lines for sanitary purposes since these pipes are already connected to residences and commercial buildings. Next to the existing line, a storm line is installed. The EPA fact sheet went on to discuss that the combined sewer lines many not be sized ideally for the sanitary flow only. It may be sized too large to allow for frequent flushing of sediment and scouring of slime layers – a function routinely performed by storm flows. Pipe size can be one factor in the ability of a sewer to flush though. Another factor may involve a higher slope that causes a greater fluid velocity through the pipe. In this case, a large pipe may not be a concern with flushing sediment and biomass. Therefore, the suitability of the combined system's pipes for sanitary flow only is affected by topography and size.

A reality of any sewer improvement project is the requirement to have accurate information regarding the location of sewer lines, the slopes, the pipe sizes, locations of lift stations (in needed), location and sizing of pipe junctions, and maintenance records. The “reality” can be harsh since some municipalities do not maintain this information through the decades. The knowledge of the essential facts to sewer improvement lies with the municipal personnel who were present during the construction of the system or that perform the maintenance. When these key resources retire or move to another community, the knowledge

goes with them. Public works departments often have layouts showing this information, but the plans are not always accurate. Hence the reason why there are specialists employed to locate utility infrastructure every time earth is excavated within a city's limits.

The effectiveness of sewer separation has been documented. In the St. Paul, Minnesota project, water quality monitoring of the watershed previously affected CSO events from 1976 to 1997 indicated that there was a 70% reduction in fecal coliform levels (EPA 832-F-99-041, 1999). However, the effectiveness of sewer separation can be overshadowed by unanticipated problems with release of storm water to surface waters on a regular basis. In Atlanta, release of separated storm water directly to surface water outfalls was predicted to decrease the water quality of local creeks (EPA 832-F-99-041, 1999). Prior to separation, storm water was carried to wastewater treatment plants and treated prior to release. Places such as Juneau, Alaska had clean storm water in comparison. The reasons given were due to the large amount of infiltration of groundwater into the storm sewer collection system which diluted storm flows and due to the high quality of the ground water that was infiltrating the system (EPA 832-F-99-041, 1999).

In spite of the costs and effort required to separate a sewer, separation is the most effective approach to CSO prevention. The combined sewer system is an outdated solution based on assumptions that are no longer valid. Regulations prohibit the release of sanitary flows to surface waters whether the flow is diluted with storm water or not. The future will likely present two realities: first, the overall population of cities will continue to increase and thus, the sanitary flows will only increase; second, the standards set by regulatory agencies will only become more restrictive. Sewer separation is the only method that directly addresses both realities. Other methods will only minimize the negative effects of combined systems.

The general case may not apply to every city's combined system. In some cases the combined systems may serve a city with a population that is declining and may only have a few isolated CSO events per year. Isolated CSO events may be a result of a small part of the system becoming overloaded and one outfall producing a CSO event. The cost and difficult construction associated with separation may not be the only way to prevent CSO events from occurring for decades. Other solutions have been used successfully.

Storage and Slow Release of Storm Water Volumes

Underground Storage and Retention Basins

One effective solution used by cities like Richmond, Virginia and Grand Rapids, Michigan was storing peak storm flows temporarily so that the peak flow could be spread out over a longer period. The problems of storing or retaining storm flow

volume are that the solids settle in the retention basin, and if the sewage is stored long enough without aeration, it will become septic. The settled solids create more maintenance for the retention basin, and the septic conditions may create problem in the retention basin or at the wastewater treatment plant once it arrives. Table 1 shows a summary of some places that have built large retention basin facilities to handle CSO events.

One site in Grand Rapids Michigan employs a 30.5 million gallon offline retention basin and wet weather treatment facility (see Figure 1). This system captures the CSO prior to it reaching the outfall. First, the captured flows passes through a mechanical bar screen and stays in an initial basin for primary settling. Following the primary sedimentation in the first basin, the overflow continues to a second retention basin. This basin is large enough to store most of the storm water event. If its volume is exceeded, then the overflow spills over into a series of disinfection contact chambers where sodium hypochlorite is dosed prior to discharge the overflow to the Grand River. The basins are equipped with a floor wash system that sweeps settled sludge to collection troughs for return to the sewer system (EPA 832-F-99-042). This storage facility is actually a combination of two CSO prevention solutions. The retention basin stores the peak storm volume to ensure a realistic load on the combined sewer system and wastewater treatment plant, and it has the capability of being a wet weather treatment facility. The wet weather treatment facility solution will be discussed in more detail later.

Another case of a large retention basin used to store CSO is in Richmond, Virginia. Richmond employs a system of retention basins that can handle a 36-million gallon storage capacity. While in storage, the untreated sewage is aerated with aeration jets and momentum headers to maintain oxygen requirements and prevent solids from settling. This keeps the volume aerated and suspended until it can be taken by the combined sewer system to the wastewater treatment plants. The basins are designed to hold the CSO volume for a period of 48 hours. (EPA 832-F-99-042).

A second example of underground storage for combined sewer systems was a 14-foot diameter, 600-ft long tunnel in Richmond, Virginia. Figure 2 shows the plan and profile views of the facility. It was the storage and conveyance structure serving two combined sewer systems that formerly had outfalls into the James River. Richmond is near some falls and rapids on the James River and these locations are ideal for recreational use. The tunnel, drilled into granite bedrock 70 ft below the grade of the combined sewer, was chosen over a rectangular retention basin because it was covered and did not cause aesthetic annoyances to the public. In addition, the tunnel construction methods used caused minimal disruption of activities to adjacent properties. Figures 3 and 4 show tunnel construction photos. During its first year of service, all CSO flows during storm events made it to the wastewater treatment plant as planned, the tunnel provided 7 million gallons of storage, and it was estimated that it only allowed 40 gallons per minute of infiltration (Chandler et al., 2003).

Table 1. U. S. Cities Using Large Storage Basins to Control CSO Events (EPA 832-F-99-042).

City	Basin Name	Year Built	Volume, MG	Covered ?	Capital Cost, \$	O&M Cost, \$	Design Criteria	Capability
Grand Rapids MI	Market Avenue	1992	30.5	Both	30M	40K	10-yr, 1hr storm	store, screen, disinfect
Richmond VA	Shockhoe	1988	41	Covered Uncovered	1.08M 344K	500K	1-month storm 7500 cfs 1st flush	store settle return
Oakland County MI	Acacia Park	1997	4.5	Covered	13.9M	207K	30-min detention for 1-yr /1-hr storm	settle disinfect
	Birmingham		9.6	Covered	35.6M	370K		
	Bloomfield Village		10.2	Covered	28.9M	500K		
San Francisco, CA	North Shore	1984	24	Covered	69M	Not Avail.	4 CSO/yr	store skim settle return
	Mariposa	1992	0.7	Covered	10.17M		10 CSO/yr	
	Sunnydale	1991	6.2	Covered	19.29M		1 CSO/yr	
	Yosemite	1989	11.5	Covered	19.16M			

The Richmond project also has some interesting engineering associated with it. First, a vortex drop structure was constructed on the McCloy end of the tunnel to help dissipate the energy of the flow over the 70 ft drop and to manage the airflow associated with displacement in the tunnel. The shaft that houses the pump station was incorporated within the vortex structure to save the money and effort of constructing two parallel shafts. Next, the tunnel holds wastewater for up to 48-hours until the wastewater treatment plant capacity becomes available. Unfortunately, this gives the solids in the wastewater time to settle in the tunnel. Water from a nearby canal is dropped into the high end of the tunnel via the vortex shaft. As the tunnels fills, sufficient scouring velocity results to flush out solids. Appendix A gives a graphical presentation of the flushing event. Finally, when the tunnel is subjected to a flow greater that the peak it was designed for, the entire facility can be isolated from the flood flow by closing only two gates.

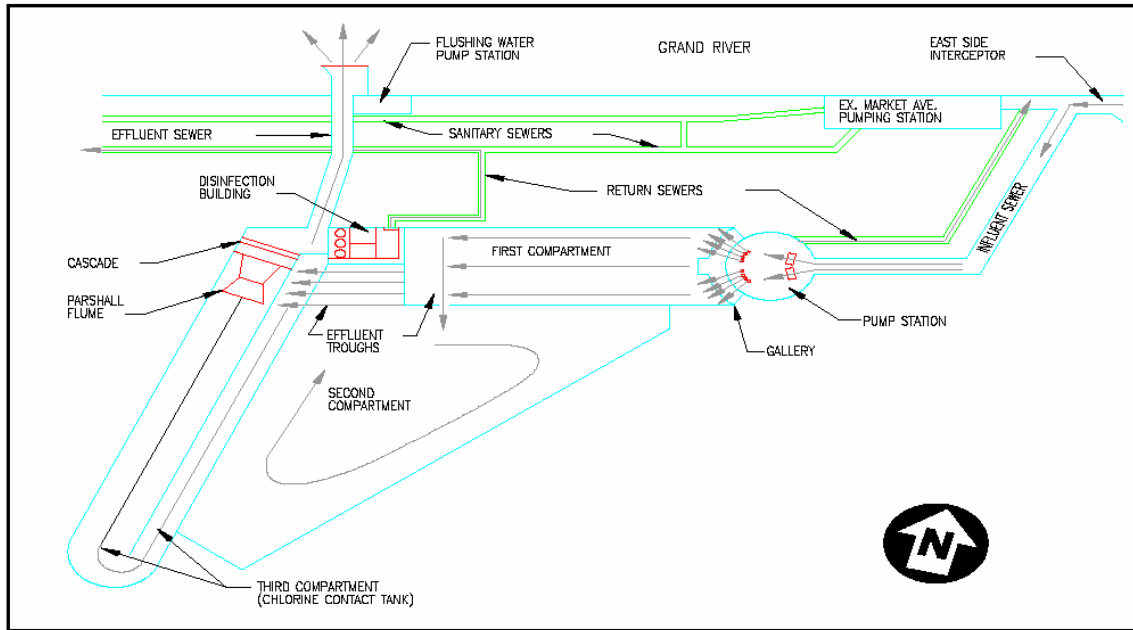

Source: City of Grand Rapids, Michigan, 1992.

Figure 1. Market Avenue Retention Basin.

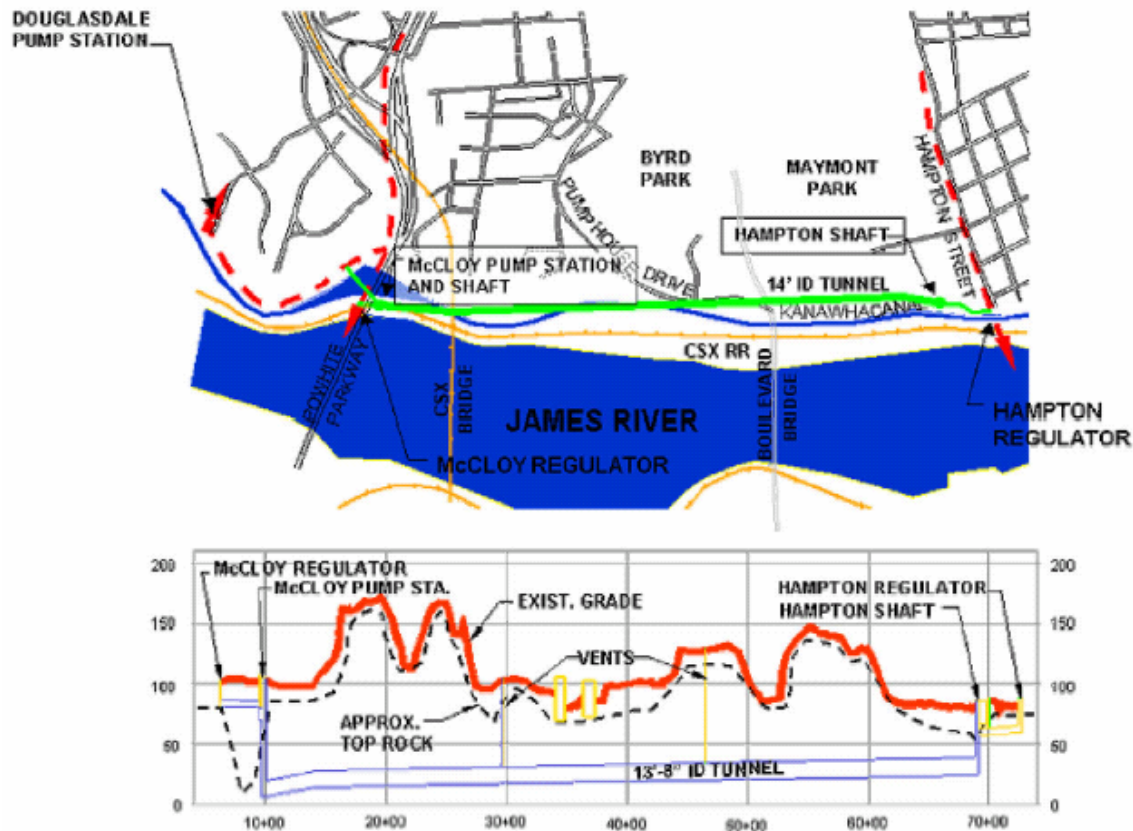

Figure 2. Plan and Section Views of the Deep Tunnel for Richmond CSO 4 and CSO 5 (Chandler et al., 2003).



Figure 3. Starter Shaft for Deep Tunnel Construction between Richmond CSO 4 and CSO 5 (Chandler et al., 2003).



Figure 4. Rock conditions in the Tunnel Shaft between Richmond CSO 4 and CSO 5 (Chandler et al., 2003).

Street Surface Storage and Flow Control

Sixty percent of the 1000 communities that have combined sewer systems in the U. S. serve populations of less than 10,000 (Dwyer, 1998). For these small combined sewer systems, the solutions used by large cities with big budgets such as those in St. Paul, Grand Rapids, San Francisco, Portland, and Richmond will not be applicable to a city with a population of less than 10,000.

Small-scale solutions on limited budgets need to be devised as well. In a combined sewer that serves 8.6 square miles in Skokie, Illinois, flow restriction devices and roadside berms were installed to limit the flow entering the combined sewer (Carr et al., 2001). The desired result was to temporarily store the storm water volume on the streets until the wastewater treatment plant capacity could be made available. Figure 5 shows the concept.

Flow regulators devices were installed in 2900 catch basins and 871 berms were constructed on streets ((EPA 832-F-99-035, 1999). As an example of an integrated solution, all roof drains were disconnected from this system as well. Figure 6 shows a profile drawing of how a catch basin equipped with a flow regulator works with berms above ground to accomplish surface storage and steady flow into the combined sewer. Figure 7 shows pictures of surface storage in action during a storm event. Carr et al. (2001) were careful to note that the ponding was shallow enough not to prevent vehicular traffic flow and was contained within the street's right-of-way. Other storage solutions were used for major arterial streets where ponding was not acceptable.

As with many solutions for combined sewers the surface storage solutions in Skokie and Wilmette required management of public perception. Involving the residents (termed "stakeholders" by the project leadership) in the solution made the difference in this case. Here is a list of what was done for the Skokie and Wilmette projects:

- Articles in community newsletters.
- Cable television programs.
- Surveys of residents; Wilmette had an excellent response on its survey of residents in the CSS.
- Letters to residents.
- Public meetings, which were usually held in public places. In a spirit of outreach, Wilmette conducted some meetings in residents' homes.
- Use of a committee of senior personnel, such as Skokie's Flood Task Committee, to monitor and guide the engineering consultant's efforts.
- Physical models, like an operating tabletop device created under the Skokie project to illustrate surface and subsurface storage.
- Assigning one public-works person to answer telephone inquiries
- Special brochures.
- Conduct of high-visibility field pilot studies that included the construction of berms, so that citizens could drive over and experience them, and the temporary flooding of streets so that citizens could observe the depth and lateral extent of ponding.
- The videotaping, for subsequent informational use, of facilities under construction, ponding on streets, and vehicles driving over berms.
- Brief discussions of the evolving street storage system as part of new resident receptions; this approach was used in Wilmette.

Once implemented, street storage accounted for half of the overall storage capacity of the collection system in Skokie. The rest was accomplished through underground basins and off-street storage. All of the storage is street storage in

Wilmette. The total construction cost of implementing the storage solutions in Skokie was \$70 million – of which only 9% was associated with the requirement for street storage. The overall construction cost was estimated to be 38% of the cost of sewer separation. In Wilmette, the total construction cost was \$35 million. This was a mere 43% of the cost of the next best option (additional combined sewers installation).

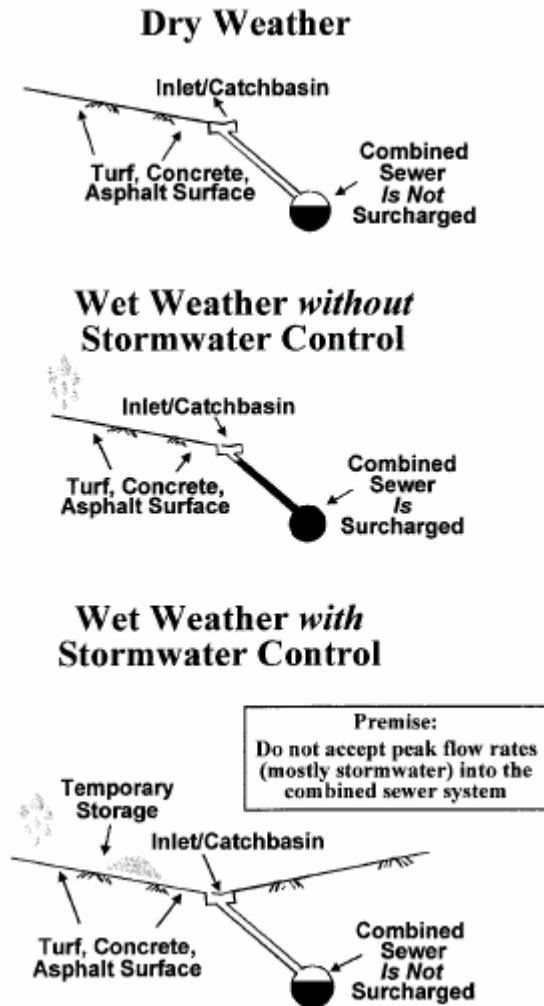

Figure 5. Concept of Street Storage of Storm Water to Minimize Peak Flows Entering the Combined Sewer (Carr et al., 2001)

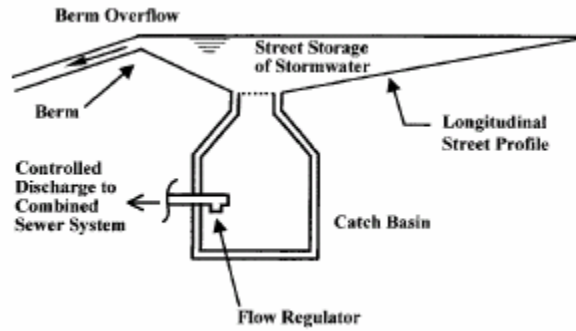

Figure 6. Using a Retention Basin with Flow Regulator and Berms to accomplished Surface Storage (Carr et al., 2001)

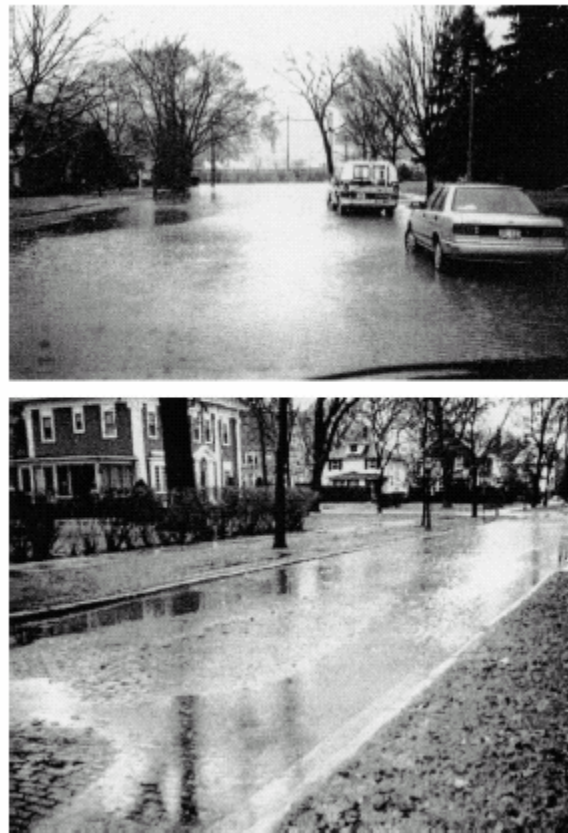

Figure 7. Pictures of Ponding in Skokie (top) and Wilmette (bottom), IL (Carr et al., 2001).

A separate study of the Skokie and Wilmette improvements (Walesh, 2000) analyzed the effectiveness of the improvements and found many positive results. Major reductions in basement flooding were accomplished, no damage to pavements, no problems with icing during the colder months, and no interference with the emergency vehicles. In addition, public acceptance was verified by the existence of no litigation resulting from damages caused by the improvements.

Control of Flow and Solids During Storm Events

The solutions discussed in this section include redirecting storm flow from residences away from combined sewer systems, flow restriction devices to promote surface storage, stream diversion, and wet weather treatment facilities. All three displace the problem of the peak flow from a storm event from the combined sewer either by location or by time. Reducing the peak level to a more manageable level for the collection system and spreading the volume over a longer period is displacing the peak flow by time. Reducing the flow going into the combined sewer altogether is displacement by location, and this approach assumes the nature of the storm water is appropriate for the alternate location.

Part of the sewer separation project done in St. Paul, Minnesota involved disconnecting roof drains from the combined sewer system. It was estimated that up to 20% of CSO volume during a storm event was coming from roof drains (EPA 832-F-99-035, 1999). For the Minnesotans, redirection of a roof drain was a task performed by residents and did not require skilled workers. The drains were re-directed to natural drainage paths and away from basements. Financial incentives were the motivation for the residents of 18,000 homes in St. Paul to redirect their roof drains. The incentive was about \$40 per residence, paid as a rebate, and was communicated by community outreach information campaigns. By 1999, 99% of the residences concerned had disconnected their roof drains.

While roof drains may occur in every residence, not every residence needs a basement sump. To quantify the number and impact of basement sumps on the CSO volume, house-to-house surveys need to be done. A visual survey in South Portland, Maine found that 300 sump pumps and 380 roof drains emptied their flows into the municipal combined sewer system (EPA 832-F-99-035, 1999). Through a monetary compensation campaign, the city was able to redirect almost all roof drains and sump pumps away from the combined sewer. The city paid \$75 for each redirected roof drain and \$400 for each redirected sump pump. This effort reduced the flow handled by the combined sewer by an estimated 58 million gallons of water per year. Their work was not complete though – the wastewater treatment plant's overall total inflow was only reduced by 2% as a result of the residential redirection campaign.

The intent behind using devices that delay or redirect storm surface flows is so that a maximum flow rate going through the combined sewer system will not be exceeded. The action of delaying the delivery of storm water to the combined sewer is referred to as flow braking. This solution may not help the wastewater treatment plant since it still produces sanitary flow diluted with storm water, but will prevent problems associated with urban runoff. The activity of redirecting the storm runoff to a location other than the combined sewer is referred to as flow slipping. This may provide relief for the combined sewer and may be better for the biological processes at the wastewater treatment plant, but it also displaces

large runoff volumes to another location. This increases the challenge of managing urban runoff.

Vortex or swirl technologies employ the said named flow in a small cylindrical basin to quickly separate the solids from the storm flow through centrifugal forces. A models that employs vortex or swirl flow pattern that was reviewed by Field and O’Conner are shown in Figure 8. The effectiveness of using a swirl technology is compared to some other known methods in Table 2.

This technology requires an accurate collection of the flow rates and anticipated solid sizes and densities in order to achieve its best efficiency. The advantages of the technology are that it has no moving parts, it handles high flow rates in a small space, and it is a flow control device. The solids are separated via a dilute underflow after the swirl flow and are delivered to the sanitary sewer. The overflow can be delivered to a storm water outfall or storage basin for subsequent treatment (Field, O’Conner, 1996).

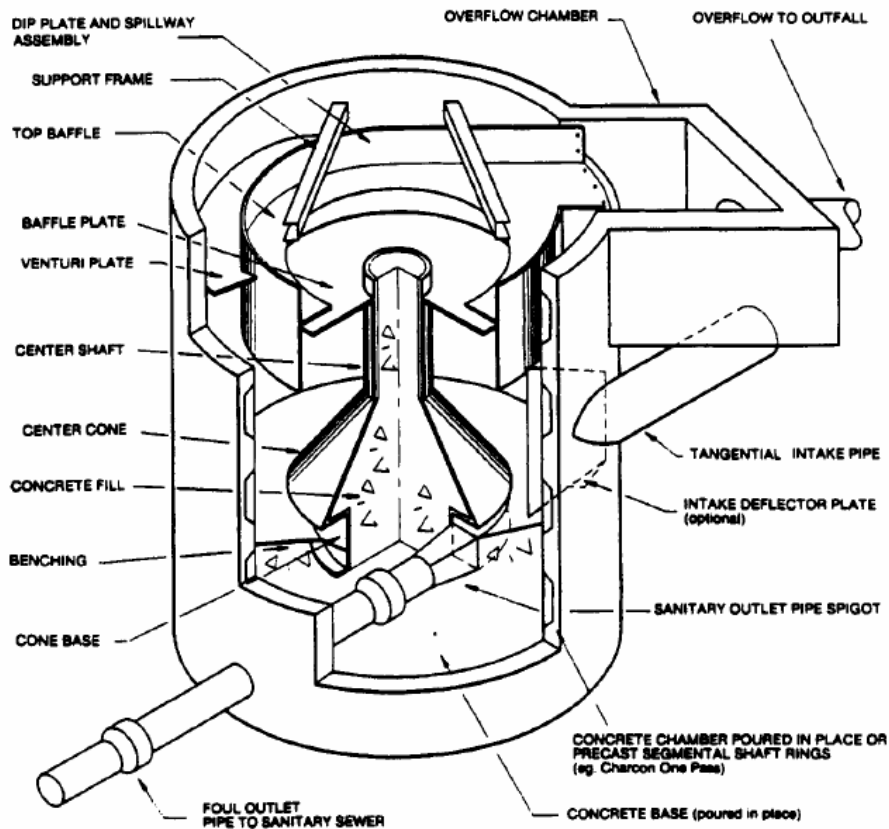

Figure 8. A Device that Employs Swirl Technology to Separate Settleable Solids (H.I.L. Technology, 1991).

Figure 9 shows an infiltration sump, in which a manhole overflows to a perforated dry well. The manhole serves as a primary sedimentation chamber for grit and

solids. The perforated sump stores the supernatant from the manhole until it can infiltrate into the ground soil. If the storm flow overwhelms both chambers, the surface storage results, but the flow entering the combined sewer remains the same. Much like a septic tank, the outflow from an infiltration sump needs sufficiently permeable soils (sandy or gravelly) above the water table to work as intended. Over 4000 of these devices were installed in Portland, Oregon between 1994 and 1998 to reduce the flow into the combined sewer. The sump chambers were typically 20 to 35 feet deep (EPA 832-F-99-035, 1999).

Table 2. Comparison of CSO Treatment Methods (Field, 1996).

Process	Hydraulic Loading, m/min	SS Removal, %	BOD ₅ Removal %	Reference
Swirl	2.4	40-60	25-60	Boner et al., 1995; Moffa (1990); Field, (1996)
Microscreen	0.81	50-95	10 to 50	Moffa (1990)
High-rate/dual-media filtration	0.98	90	*	Field, (1996)
Dissolved air flotation	0.1	80	*	
Sedimentation	0.02	20-65	30	Michelback and Gebard (1996); Moffa (1990); Field (1996)
Sedimentation with coagulant	*	50-95	65	Averill et al., (1997), Brouwer (2001)

* Indicates no data available

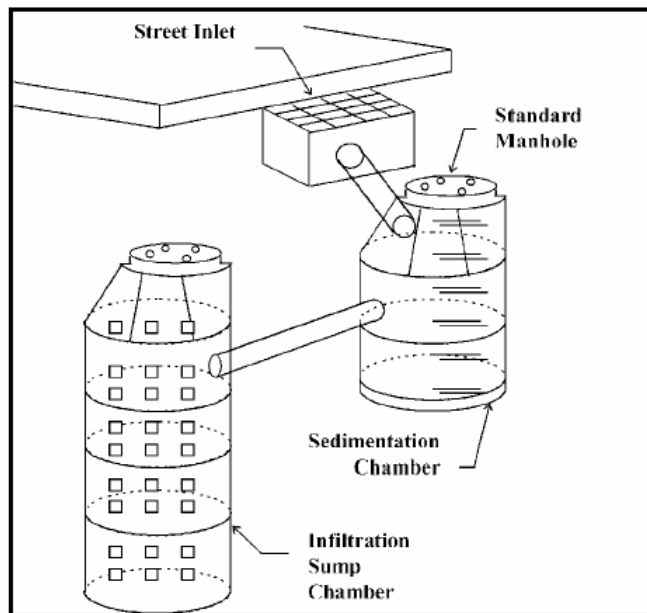

Figure 9. Infiltration Sump (EPA 832-F-99-035, 1999).

Infiltration sumps are not good solutions for systems collecting runoff containing dissolved pollutants. In addition, the manhole chambers will require regular maintenance to clean out the solids that settled during retention. This may be

done manually by municipal workers or occur through the use of a basin flusher (see Figure 10). The amount of solids can be reduced through other maintenance programs such as street cleaning.

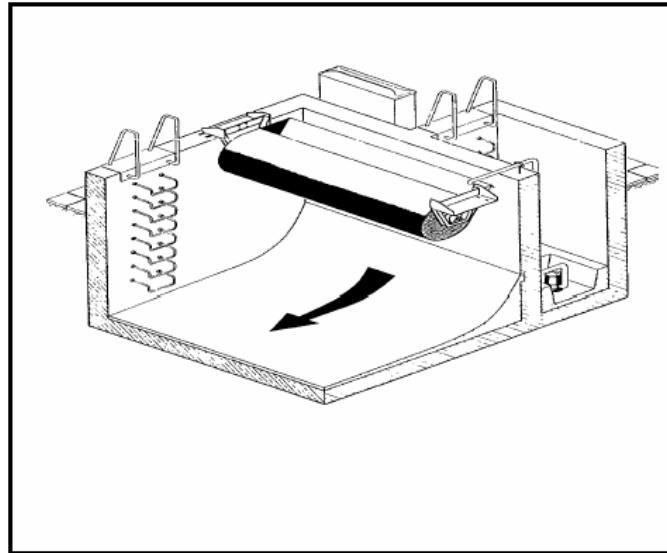

Figure 10. Use of a Tipping Flusher to Clean Basins (EPA 832-F-99-042, 1999).

The flow slipping concept was implemented in South Portland, Maine. The community eliminated 30 of 750 storm water catch basins and redirected storm flow to natural drainage or separate storm sewers. The elimination of catch basins by placing a manhole cover without holes over them reduced the volume of storm water entering the sewers by 12 million gallons per year. A careful study was completed prior to capping the catch basins in South Portland. The study confirmed that capping the catch basins would not cause adverse safety or flood damages. The communities of Skokie and Wilmette, as discussed earlier, also applied flow slipping since some of the storm flows were redirected to natural drainage paths.

In some communities, streams carrying natural flows or man-made urban runoff, provide substantial inflow to a combined sewer system. As with any large-scale solution, this will require public acceptance and involvement. Redirecting streams away from combined sewers may also require installation of new pipes and conveyance structures to include open channels. Portland, Oregon successfully diverted a stream to a wetland. The wetland treats the runoff and then discharges it to a natural water feature. This stream redirection project was the first of six planned and involves the community. For example, programs were implemented to bring in student field trips to plant wetland plants and use the wetland treatment area as an outdoor nature classroom (EPA 832-F-99-035, 1999).

The inflow reduction solutions were implemented as a part of an integrated solution for many of communities that made combined sewer system improvements in the area of inflow reduction. Table 3 provides a cost summary of many of the options discussed in this section. These costs are capital costs, but maintenance of flow control structures is important as well. Proper maintenance, such as street and basin cleaning affects the amount of solids loads going into catch basins and is street cleaning.

New York City actively works to prevent sediment and trash from ending up in its storm sewer system. Here, over 50% of the city's 18,800 curb kilometers is swept with street cleaners one to three times per week (EPA 832-F-99-038, 1999). Property owners are required to regularly sweep sidewalks and gutters daily or risk being fined. South Portland, Maine sweeps about 160 kilometers of curb and collects 1500 cubic meters of material annually. It is very likely that much of this material would enter the collection system if not periodically removed from the street surface. On average, street sweeping costs \$62 per curb kilometer (as of the 1999 EPA report cited, which is likely to vary with the fluctuating cost of fuel). Total amounts were not determined for the City of New York.

Municipal programs that seem to have nothing to do with combined sewers, like management of household hazardous waste, can help prevent pollution from CSO events. Jefferson County, Kentucky collected 68,000 kg of household hazardous wastes from 2080 households and 85% were recycled (EPA 832-F-99-038, 1999). Programs such as these are important for pollution prevention since many people may dispose of unwanted excess household hazardous wastes by pouring them down the drain. Hazardous wastes poured down the drain could be released directly to the environment in a CSO event.

Table 3. Costs of Inflow Reduction Activities (EPA 832-F-99-035, 1999)

Technology	Cost	Comments
Roof Drain Redirection	Costs range from \$45-\$75 for individual homeowners to disconnect	Rebates for individual homeowners to disconnect
Basement Sump Pump Redirection	Disconnection costs approximately \$300-\$500 per home	Incentive programs usually used to reimburse homeowners
Flow Restriction and Flow Slipping	Flow restrictors can cost between \$500 and \$1,200; covers for catch basins to encourage flow slipping can cost as little as \$100	Indirect additional costs may be incurred because of additional water pooling on surface streets
Storm Water Infiltration Sumps	\$2-\$8 per 1,000 gallons inflow Removed	Costs are closely related to the type of soil, the density of the sumps, and the desired amount of inflow reduction
Stream Diversion	\$17.4 million for 29.75 acre stream diversion into a created wetland in Portland, OR	Costs included land acquisition, storm sewer separation and new trunk lines, and wetland design and construction.

Water conservation has an obvious effect on the how much sanitary flow enters the combined sewer system. The City of Seattle has saved 1.7 million gallons per day from entering the sewer collection system through water conservation programs in 1997. Seattle spent \$1.4 million on the replacement of over 8000 toilet fixtures in residences and \$1.2 million on water conservation technology upgrades in commercial properties to accomplish their water savings (EPA 832-F-99-038, 1999). Water conservation not only conserves drinking water resources and saves consumers money through the purchase of less drinking water, but also works toward preventing pollution from CSO events.

Wet Weather Treatment Facilities

The Muddy Creek Wet Weather Treatment Facility is not a wastewater treatment plant, but it is essential to controlling CSO events from polluting the Ohio River near Cincinnati (Szabo et al., 2005). It has the ability to allow all flow to bypass it to the combined sewer, or to take flow offline to be screen, settled, and stored until the combined sewer can take the underflow to the wastewater treatment plant. A stoplog weir is used to take the flow offline and into the facility during wet weather events. A storm event is stated to be “contained” when all of the bypassed flow does not exceed the volume of tanks 1 and 2 (see Figure 11). However, once the tanks 1 and 2 are filled, the clarified effluent “spills” over, and is released to Muddy Creek (referred to as “fill and spill”). The maximum flow that the trunk sewer can deliver is $52 \text{ m}^3/\text{s}$ and the maximum underflow that the sedimentation tanks can deliver to the wastewater treatment plant is $3.2 \text{ m}^3/\text{s}$. Therefore, when the tanks reach their maximum capacity and can no longer receive flow, they are bypassed and the center path on Figure 11 is taken. The bending weir equipped with fine screens lowers when the flow reaches a height corresponding to $3.2 \text{ m}^3/\text{s}$. Figure 12 shows how the overflow from the flow regulator is routed through the fine screen on the bending weir and out to Muddy Creek. The underflow from the flow regulator is sent to the wastewater treatment plant. If the flow in the trunk sewer exceeds a height corresponding to $6.9 \text{ m}^3/\text{s}$, then it overtops the stoplog weir and goes untreated to Muddy Creek.

First flush is a concept that does not apply to all watersheds and its existence in some form is debated. The concept describes what happens at the beginning of a storm event when the peak flow begins to enter the combined sewer system. It is thought by many to flush out accumulated sediment, slime, and solids that were not carried to the wastewater treatment plant under the velocity of normal or low flows. The first flush volume is considered to be heavily laden with solids and BOD and is the cause of the negative effects of CSO events. The first flush concept has not been proven to occur in each system, but the authors in the Cincinnati Case Study (Szabo et al., 2005) proved that a first flush did exist in the Muddy Creek catchment by characterizing a high pollutant load early in the runoff event. See Figure 13.

Ten storm events were used to evaluate the efficacy of the facility. Five events were completely contained and five were not. Two storm events exceeded the capacity of the facility (flow overtopped the stoplog weir). When the facility was storing the storm flow and then releasing it slowly to the wastewater treatment plant, then removal of 75% of BOD and 85% total suspended solids (TSS) resulted (“contained” event). When the facility was mostly settling solids and no flow is bypassing tanks 1 and 2, a 50% BOD removal and 50-70% TSS removal resulted (“fill and spill” event). When the facility was mostly settling solids and some flow was going to the bypass line (after first flush), then 20% BOD removal and 25% TSS removal resulted. Even when the overall facility’s capacity is exceeded and some flow bypasses it, capturing the first flush still resulted in 20% BOD removal and 25% TSS removal. Capturing and storing first flush was key to the best pollutant removal.

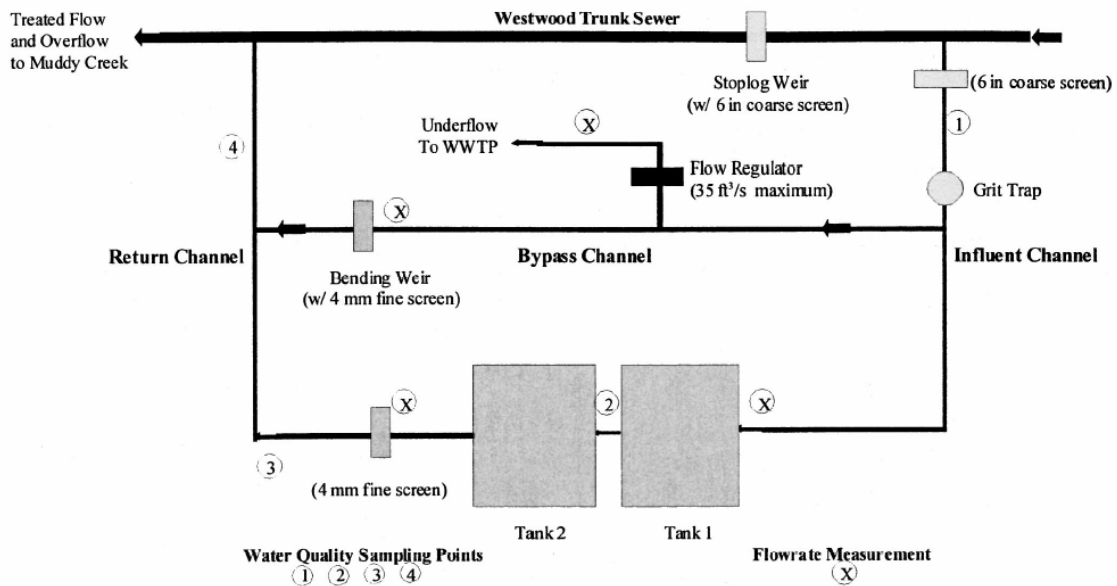

Figure 11. Muddy Creek Wet Weather Treatment Facility (Szabo et al., 2005).

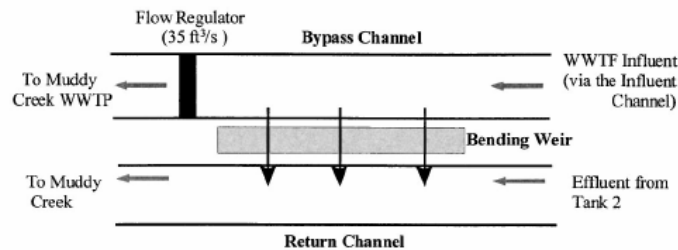

Figure 12. Plan View of the Bending Weir (Szabo et al., 2005).

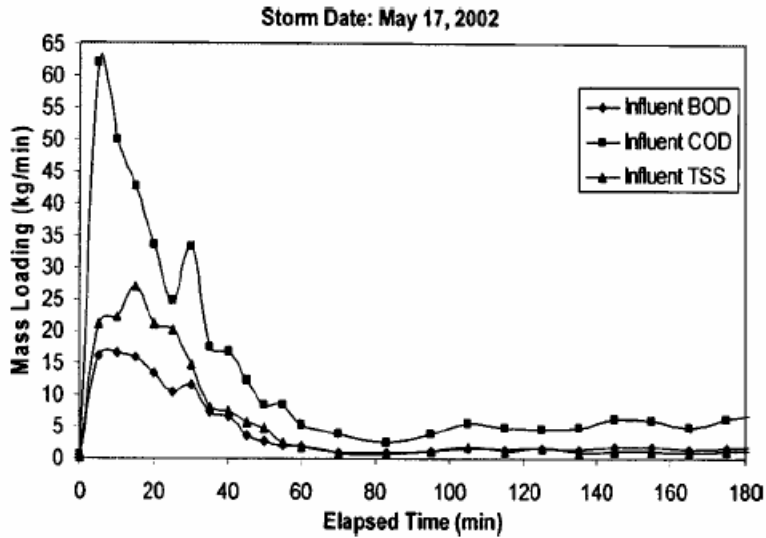

Figure 13. First Flush Mass Loading in the Muddy Creek Catchment (Szabo et al., 2005).

Conclusions

Many options for prevention of pollution from CSO events have been presented. Solutions such as sewer separation are very expensive and exhaustive. Others required minor modifications of existing combined sewer catch basins to accomplish surface storage. Solutions ranged from serving major cities to small ones, and to preventing the activation of one to several CSO outfalls. The following conclusions can be drawn:

- Separating sewers is the only way to totally prevent sanitary flows from contaminating the storm flow. It is also the most difficult option to construct and the generally the most expensive.
- Retention basins have proven effective in storing storm flows until the capacity at the wastewater treatment plant becomes available. This is a good solution for a combined system with many CSO outfalls, relatively short storm events and infrequent floods, and for a community that desires to have construction and structures out of sight.
- Surface storage of storm flows can be a relatively inexpensive and good solution for a small community of flat topography. Since the solution is not out of sight, public acceptance is vital.
- Several flow control devices such as weirs, infiltration sumps, and vortex/swirl chambers help to implement surface storage and to prevent overloading of combined sewers.
- Efforts to reduce the amount of water and solids entering combined always contribute to prevention of CSO events. These include redirection of the flow from roof drains and basement sump pumps away from the combined sewer, stream diversion, water conservation, street cleaning, and hazardous waste management.

- Like retention basins, wet weather treatment facilities work best for those systems that reduce all of the collected flows into one trunk line prior to an outfall to a surface water body.
- Wet weather treatment facilities have the most flexibility to handle variances in storm flow volumes and rates, solids loading, and organic oxygen demand.

References

Averill, D., Mack-Mumford, D., Marsalek, J., Andoh, R., and Weatherbe, D. (1997). "Field Facility for Research and Demonstration of CSO Treatment Technologies." *Water Science and Technology*, 36:8–9:391–396.

Boner, M. C., Ghosh, D. R., Harper, S. R., and Turner, B. G. (1995) "Modified vortex and UV disinfection for combined sewer overflow treatment." *Water Science and Technology*, 31:3–4:263–274.

Brouwer, G. (2001) "Storm Water: Stand-alone Wet-Weather Facility will Treat CSOs." *Civil Engineering, New York*, 71:11:14–15.

Carr, R. W., Esposito, C., Walesch, S. G. (2001) "Street-Surface Storage For Control Of Combined Sewer Surcharge," *Journal of Water Resources Planning and Management*, 127:162.

Chandler, K., Duval, G., Stone, R., Maisch, F. E., Gerulat, E. M., Cronin, E. J., Fee, D. F. (2003) "Innovative Design And Operational Features For A CSO Tunnel: Spiral Drop, Hydraulic Transient Control, And Operating Modes," *WEFTEC 2003 Proceedings*.

Dwyer, T. (1998). "Overview of the CSO policy and guidance documents." *Proceedings of Small Communities Combined Sewer Overflow Workshop*, Indianapolis, February 24–25.

EPA (1999) "Combined Sewer Overflow Management Fact Sheet: Pollution Prevention," *EPA 832-F-99-038*, Office of Water, Washington, DC.

EPA (1999) "Combined Sewer Overflow Management Fact Sheet: Sewer Separation," *EPA 832-F-99-041*, Office of Water, Washington, DC.

EPA (1999) "Combined Sewer Overflow Technology Fact Sheet: Retention Basins," *EPA 832-F-99-042* Office of Water, Washington, DC.

EPA (1999) "Combined Sewer Overflow Technology Fact Sheet: Inflow Reduction," *EPA 832-F-99-035* Office of Water, Washington, DC.

Field, R., O'Conner, T. P. (1996) "Swirl Technology: Enhancement of Design, Evaluation, and Application." *Journal of Environmental Engineering*, 122:8:741.

Maier, R. M., Pepper, I. L., Gerba, C. P. (2000) *Environmental Microbiology*, Academic Press, San Diego, California, U.S.A., Ch 15.

Michelbach, S., and Gebhard, J. W. (1996). "Settleable Sewer Solids at Stormwater Tanks with Clarifier for Combined Sewage." *Water Science and Technology*. 33:9, 261–267.

Moffa, P. E. (1990). *Control and Treatment of Combined Sewer Overflows*, Van Nostrand Reinhold, New York, 1–226.

Szabo, J. B., Buchberger, S. G., Bishop, P. L. (2005) "Performance of Wet Weather Treatment Facility for Control of Combined Sewer Overflows: Case Study in Cincinnati, Ohio," *Journal of Environmental Engineering*, 131:175.

Walesh, S. G. (2000). "Street storage system for control of combined sewer surcharge." *EPA/600/R-00/065*, U.S. Environmental Protection Agency, Washington, D.C.

Appendix A. Additional details from the Richmond Deep Tunnel Project.

Hydraulic Loading of Tunnel as a function of time during a storm event.

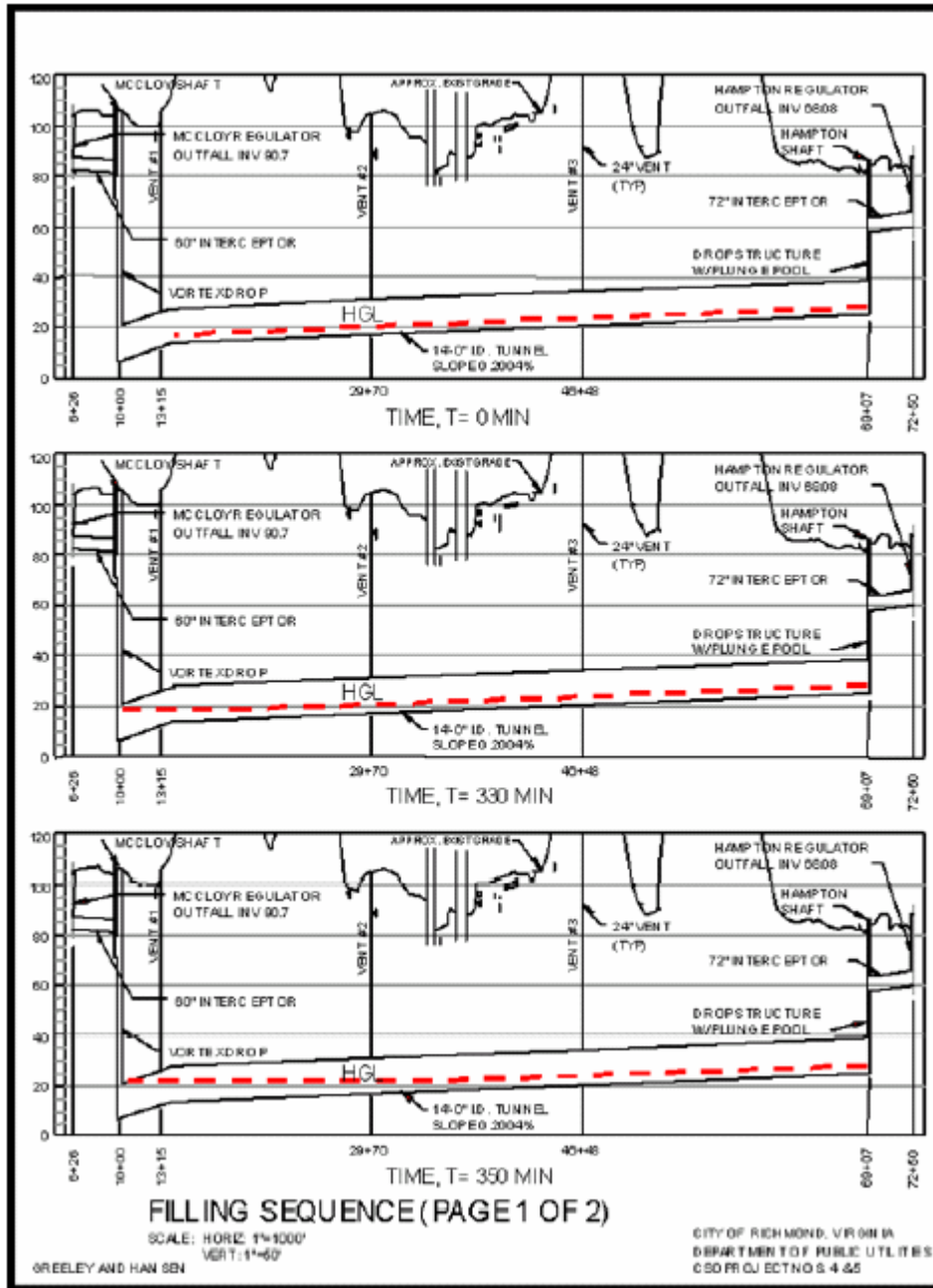

APPENDIX A. Additional details from the Richmond Deep Tunnel Project.

Hydraulic Loading of Tunnel as a function of time during a storm event (continued).

