

# Concrete Towers for Onshore and Offshore Wind Farms

CONCEPTUAL DESIGN STUDIES

## PROFILES OF THE CONCRETE CENTRE AND GIFFORD



### The Concrete Centre™

The Concrete Centre is dedicated to helping architects, designers, engineers, constructors, developers and clients get the best out of concrete and hence improve their own efficiency.

With a remit to technically develop and promote appropriate concrete solutions, the Centre provides a focal point for innovation, research, development and technical excellence. This is achieved by developing design guidance on a wide range of topics such as structural design, fire, sustainability, acoustics, thermal properties and durability, and providing a comprehensive education and training programme to provide in-depth knowledge and examination of concrete issues and developments.

The use of concrete in the UK wind energy sector to date has been limited predominantly to onshore foundation applications. This contradicts experience from elsewhere, where application of concrete for pylons and offshore applications, such as foundations, is commonplace. As such, The Concrete Centre is committed to challenging the UK wind industry's current thinking on wind tower design and to illustrate how the benefits of concrete construction can be realised more fully.

For more information on the use of concrete in wind tower applications and the services that the Centre offers, including publications, seminars and technical support and advice from our regional teams, please visit [www.concretecentre.com](http://www.concretecentre.com)

### Gifford



Gifford is a leading engineering design consultancy with over 50 years experience of strategic planning, design development and construction design of major projects for the built and natural environment.

Project experience covers: highways, rail and marine transport infrastructure; industrial and commercial facilities including shipyards, and production plants; energy infrastructure for storage facilities, power stations and wind farms; buildings of all kinds; urban regeneration; environmental management, mitigation and restoration; resources management including waste management.

Founded on the basis of invention of new prestressing systems for concrete and on the innovative design of prestressed concrete structures, the firm has maintained a tradition of innovation in emerging materials, technologies and fields of engineering. These have included pre-fabricated building systems, hovercraft, wave energy systems, wind turbine blades, strengthening techniques for structures and low energy buildings.

Resources include a network of UK and overseas offices with over 600 staff covering disciplines and specialisms relating to civil, structural, building and environmental engineering and science, analysis and modelling, project information production and project management.

## PREFACE

Considered opinion supporting concrete as an efficient high performance structural material, in the rapidly growing UK programme for wind energy generation, recently led to the need for verification of this potential. In 2003, The Concrete Centre commissioned Gifford to undertake conceptual design studies of concrete towers for wind energy converters. Studies were subsequently undertaken in two stages during a 15 month period between early 2004 and May 2005.

As offshore sites were perceived to present the greatest opportunities for the UK, initial research focused on this field of study. It is appreciated that, while many common issues exist between onshore and offshore wind tower structures, there are also many important differences that could significantly influence design concepts and feasibility.

This document draws together the results presented in the onshore and offshore research into one publication. It presents ideas and issues on the design and deployment of concrete towers and associated structures, and points to a real opportunity for the substantial and economic use of concrete tower structures in future wind energy developments. We trust that it will help to raise awareness of this important potential.

Alan Bromage  
*The Concrete Centre*

Alan Tricklebank  
*Gifford*

---

Prepared by: A H Tricklebank  
BSc Eng(Hons) CEng FStructE FICE FCIWEM  
*Gifford and Partners Ltd*

P H Halberstadt  
MEng(Hons) ACGI Civil Eng  
*Gifford and Partners Ltd*

B J Magee  
BEng Phd CEng MICE MICT  
*The Concrete Centre*

With advice and  
assistance from: A Bromage  
BSc CEng MICE MCIM  
*The Concrete Centre*

# CONTENTS

## PROFILES OF THE CONCRETE CENTRE AND GIFFORD

### PREFACE

#### 1 INTRODUCTION

- 1.1 Background
- 1.2 Looking to the future
- 1.3 The role of concrete
- 1.4 Current applications of concrete in the wind energy sector
- 1.5 Background design considerations
- 1.6 Towards more competitive concrete design solutions
- 1.7 Aim of this document

## STUDY OF CONCRETE TOWERS FOR ONSHORE WIND FARMS

#### 2 DESIGN PHILOSOPHY

- 2.1 General approach and configuration
- 2.2 Design for construction
- 2.3 Design concepts

#### 3 DESIGN

- 3.1 Indicative designs
- 3.2 Foundations
- 3.3 Tower elements
  - 3.3.1 Base zone
  - 3.3.2 Middle zone
  - 3.3.3 Upper zone
- 3.4 Prestressing of the tower
- 3.5 Thin walled shell units
- 3.6 Joints
- 3.7 Construction sequence
- 3.8 In-situ slipform construction
- 3.9 Cranage and lifting
- 3.10 Structural analysis

#### 4 QUANTITIES AND COSTS

#### 5 CONCLUSIONS

#### 6 FIGURES

# STUDY OF CONCRETE TOWERS FOR OFFSHORE WIND FARMS

## 7 DESIGN PHILOSOPHY

- 7.1 Design drivers and approach
- 7.2 Design scenarios and criteria

## 8 DESIGN

- 8.1 Tower configuration
- 8.2 Pylon
- 8.3 Foundation and substructure
- 8.4 Structural design methodology
- 8.5 Commentary on life cycle issues
- 8.6 Description of outline designs
  - 8.6.1 Continuous taper design
  - 8.6.2 Necked stem design
  - 8.6.3 Concrete pylon with concrete gravity foundation
  - 8.6.4 Concrete pylon on steel monopile
- 8.7 Pylon fabrication and erection
  - 8.7.1 Precast concrete method
  - 8.7.2 Slipforming the tower
  - 8.7.3 Prestressing techniques and details
  - 8.7.4 Ancillary details
  - 8.7.5 Formwork for precast units
  - 8.7.6 Joint details
- 8.8 Construction and installation of the foundation and tower
  - 8.8.1 Current installation methods for steel towers
  - 8.8.2 Installation of gravity foundations
  - 8.8.3 Alternative proposals for caisson and tower construction and installation
- 8.9 Versatility of the concrete tower concept
- 8.10 Standardisation of pylon geometry
- 8.11 Prototype and demonstration designs

## 9 QUANTITIES AND COSTS

## 10 COMPARISON OF STEEL AND CONCRETE TOWERS

- 10.1 Comparison of the dynamics of steel and concrete towers
- 10.2 Comparison table of offshore tower structures' characteristics

## 11 CONCLUSIONS

## 12 FIGURES

## 13 GENERAL CONCLUSIONS

## 14 REFERENCES

## A1 APPENDIX A

- Embodied CO<sub>2</sub> estimates for wind towers

## LIST OF FIGURES

### STUDY OF ONSHORE WIND TOWERS

Figure No.

- 1.1 70m CONCRETE TOWER - Outline and indicative dimensions
- 1.2 100m CONCRETE TOWER - Outline and indicative dimensions
- 1.3 HYBRID TOWER - Arrangement with steel upper section
- 1.4 70m CONCRETE TOWER - Assembly from precast concrete units
- 1.5 100m CONCRETE TOWER - Assembly from precast concrete units
- 1.6 TOWER CONSTRUCTION SEQUENCE
- 1.7 ASSEMBLY OF RING UNITS INTO TOWER SECTIONS
- 1.8 TOWER SECTION JOINTS - Anchorage section and plain joints
- 1.9 RING UNITS - Reinforcement and segment joints
- 1.10 TENDON RESTRAINTS - Yokes to plain units

### STUDY OF OFFSHORE WIND TOWERS

Figure No.

- 2.1 GENERAL STUDY SCENARIO
- 2.2 CONCRETE TOWER - Continuous taper design
- 2.3 CONCRETE TOWER - Necked stem design
- 2.4 CONCRETE FOUNDATION - Gravity base solution
- 2.5 CONCRETE PYLON - With steel monopile substructure
- 2.6 PRODUCTION PROCESS - Concrete pylon
- 2.7 TOWER SECTIONS - For offshore erection
- 2.8 TOWER SECTIONS - Showing build-up from precast concrete ring units
- 2.9 PRECAST CONCRETE RING UNITS - Outline details
- 2.10 JOINT BETWEEN TOWER SECTIONS - Internal prestress arrangement
- 2.11 COMPOSITE/HYBRID ARRANGEMENTS FOR WIND TOWER STRUCTURE - Flexibility of solution
- 2.12 INSTALLATION OF CONCRETE TOWER AND GRAVITY FOUNDATION - Methods 1& 2 (Pylon construction offshore)
- 2.13 INSTALLATION OF CONCRETE TOWER AND GRAVITY FOUNDATION - Method 3 (Pylon construction inshore)
- 2.14 DYNAMIC RESPONSES OF VARIOUS TOWER DESIGNS

# 1 INTRODUCTION

## 1.1 Background

Harnessing wind energy is one of the most commercially developed and rapidly growing renewable energy technologies, both in the UK and worldwide. In 1991, the first UK wind farm deployed ten 400kW turbines. Just 14 years later, turbines capable of generating ten times that energy output are in use. Energy generation sophistication has evolved through achievements in engineering design, aerodynamics, advanced materials, control systems and production engineering. Rotor diameters have grown from 30m to over 80m, with diameters of up to 120m now being trialled. Tower heights have risen from 40m to over 100m, and power outputs from 200kW up to 5MW. These dimensions and ratings are set to grow even further.

Looking to the future, the UK is committed to working towards a 60% reduction in CO<sub>2</sub> emissions by 2050. A core part of achieving this aim is the development of renewable energy technologies such as wind. The UK's wind resources are the best and most geographically diverse in Europe, more than enough to meet the target of generating 10% of UK electricity from renewable energy sources by 2010, with an aspirational target of 20% plus by 2020.

The current UK consumption of electricity supplied by the grid is about 35TWh (Terawatt hours) or 35,000GWh (1 Gigawatt hr = 10<sup>6</sup> KW hours). The target of 10% therefore represents delivery of 3.5TWh.

In its recent report *Offshore Wind at the Crossroads* <sup>[1]</sup>, the British Wind Energy Association (BWEA) concludes that, with modest additional government support, offshore wind capacity could rise to 8GW by 2015. By then, Rounds 1 & 2 would be completed and a new Round 3 would have started, taking installed capacity to 10.5GW by 2017. Annual growth rates of installed capacity could be expected to be 1.2GW per year early in the next decade. Other scenarios see this increasing to 2GW per year by 2015 <sup>[2]</sup>.

The table below sets out the effects of this scenario for offshore capacity, combined with current predictions for onshore capacity growth. Capacity utilisation factors for offshore wind of about 36% are assumed, currently growing to 38% over time for new capacity. For onshore wind a utilisation factor remaining at about 30% is assumed.

*[The link between rated capacity output is easily calculated, for example as follows:*

*Current Onshore Rated capacity = 1.0GW Output = 1.0GW x 0.30 x 365 x 24 = 2628 GWh]*

	2006 Capacity GW	2006 Annual Output TWh	% of Total UK Output	2024 Capacity GW	2024 Annual Output TWh	% of Total UK Output
Offshore	0.2	0.7	0.3%	28.3	94.0	26.2%
Onshore	1.0	2.6	0.7%	10.0	26.0	7.2%
Total	1.2	3.3	1.0%	38.3	120.0	33.4%

At the time of writing this report, the rate of installation of offshore capacity is below expectation due to technical, cost and financial issues. It is believed that these issues are likely to be resolved during the next two years, and that actual installation will trend back towards target over the next four to five years. Given the benefits of construction, installation cost and risk reduction, improved turbine reliability and suitable adjustments to the financial support mechanisms, all of which can be reasonably expected, there are good grounds for thinking that UK offshore and onshore wind can contribute some 33% of the required electrical power output by 2024.

## 1.2 Looking to the future

At present, most recently installed onshore UK wind towers typically have a rotor diameter of 40m, tower height of 70m and power outputs between 1.0 and 2.75MW. The largest individual turbines currently installed offshore (at Arklow Bank) are rated at 3.6MW, with a rotor diameter of 111m and a hub height of 74m. However, even larger machines are likely to be installed over the next few years as various manufacturers release new generation turbines in the output range of 4.5 to 5MW with machines of up to 7MW currently under consideration.

Although these larger generating units are primarily aimed at the offshore industry, experience with some larger onshore prototypes demonstrates the potential viability of onshore exploitation where the constraints of transportation of components can be removed or overcome. To date, a 4.5MW turbine has been installed as a prototype on an onshore wind farm near Magdeburg, Germany. Onshore turbines of this size will require blades in the region of 60m long. They must be supported on taller, stronger towers that stand up to and beyond 100m tall.

Onshore sites generally require taller towers than offshore sites for a given power output. The principal onshore factors include a lower blade tip speed to limit noise generation, leading to relatively larger rotor diameters. The rotor is set at a greater height above ground to overcome greater surface friction effects on the wind speed profile. Onshore towers are currently frequently limited in height by local government planning restrictions to around 100m at the tip of the rotor.

In view of the limited number of available onshore sites with suitable wind climate, location and access, it will become increasingly important to make best use of principal sites by harvesting the optimum proportion of resource available, using the best technologies available. This will put great emphasis on using towers in the range of 100m plus, exceeding existing heights currently used on most UK onshore sites.

In summary, the future trend for UK wind farms is that they are likely to require taller towers, supporting higher powered, longer bladed turbines, many of which may be located at remote or less accessible sites.

### 1.3 The role of concrete

The consequence of taller wind towers is the need to increase the structural strength and stiffness required to carry both increased turbine weight and bending forces under wind action on the rotors and the tower, and to avoid damaging resonance from excitation by forcing frequencies associated with the rotor and blades passing the tower. In turn this will require larger cross sectional diameters, which may introduce significant transportation problems, bearing in mind that 4.5m is the practical limit for the diameter of complete ring sections that can be transported along the public highway. It is clearly shown in this report that concrete towers can accommodate these requirements and also offer a range of associated benefits.

Concrete is a versatile material and can be used structurally in many different ways. Structural concrete may be **reinforced** (with steel bar or other suitable materials), **prestressed** (with pre- or post-tensioned steel bars or strands, or other suitable materials) or **mass** (with no reinforcement). Concrete used for structures should be regarded as a high performance material. Its properties (particularly, but not only, strength), can be tuned by design over a wide range from normal structural grade to very high performance grades. Mass concrete has a very long history as a construction material. In the modern era, reinforced concrete has been used for at least 100 years and prestressed concrete for over 70 years. Some key benefits of the material are summarised here:

- **Low maintenance** – Concrete is an inherently durable material. When designed and constructed properly, concrete is capable of maintaining its desired engineering properties under extreme exposure conditions.
- **Cost-competitive and economical** – Concrete solutions can combine low first cost with significantly enhanced life cycle value. Concrete's constituent materials are relatively low cost. The work processes for concrete production are not inherently expensive and are routinely engineered and mechanised to a high level for similar production situations. The potential requirement for the production of significant numbers of similar structures with some commonality of elements also provides a major opportunity for a highly production-oriented design, thereby adding significantly to the potential overall economy.

For tall wind towers, in particular those standing in excess of around 90m, concrete can deliver cost-effective, long-life solutions. Solutions with a practical design life of 40 to 60 years plus are feasible. This opens up the possibility of significant life cycle cost savings on towers and foundations if coupled with a turbine re-fit philosophy. It may be anticipated that improved technology turbines would be installed at each re-fit.

Large diameter structures can easily be constructed in concrete without disproportionate increases in cost. In addition to potentially lower relative grid-connection and operational costs, taller more durable towers can generate increased levels of power and deliver lower payback times.

- **Design and construction flexibility** – Concrete's versatility enables design solutions with no restriction on height or size to meet challenges influenced by site conditions and accessibility. Designs can be adapted to both in-situ and precast construction methods and offer a wide range of construction flexibility to suit site conditions, availability of specialised plant and labour and other local or market circumstances.
- **Mix design flexibility** – Concrete is an adaptable construction material that can be finely tuned through alterations in mixture design to optimise key parameters such as strength, stiffness and density.
- **Excellent dynamic performance** – Concrete has good material damping properties. In particular, prestressed concrete has a high fatigue resistance, providing more tolerance and less risk from dynamic failure. By delivering improved levels of damping to vibrations and also noise, concrete designs may play a central role in gaining public acceptance in environmentally sensitive areas.
- **Low environmental impact** – Not only is reinforced concrete 100% recyclable, but its embodied CO<sub>2</sub> and energy content can be much lower than that of other construction materials. For instance, for a typical 70m high onshore wind tower configuration, relative to tubular steel, the embodied CO<sub>2</sub> content of a prestressed concrete design option is approximately 64% lower. In addition, a concrete wind tower has the ability to consume CO<sub>2</sub> from the atmosphere both during and after its service life (see Appendix A for further detail).



## 1.4 Current applications of concrete in the wind energy sector

The use of concrete in the wind energy sector has so far been predominantly in foundation applications, either to form gravity foundations or pile caps. There have been at least two major projects offshore, at Middle Grunden and Rødsand wind farms, which both use gravity foundations with 'ice cream cone' stems to suit the particular conditions of the Baltic Sea. The associated Danish energy production and distribution company ENERGI E2 have declared significant cost savings through the use of concrete gravity foundations for offshore wind farms and reportedly intend to exploit this potential for future sites such as London Array<sup>[3]</sup>.

In terms of pylon applications, concrete solutions are being exploited onshore by at least three turbine manufacturers: Enercon, GE Wind and Nordex.

Enercon<sup>[4]</sup> has progressed furthest with the development of concrete pylons, with a prototype precast concrete solution now having moved into full scale commercial production. Enercon now offers the option of a concrete tower solution for turbines with hub heights of 75m and above. For hub heights of up to 113m, reinforced precast concrete rings of around 3.8m high with wall thickness of around 350mm are used. The rings range from between 2.3m and 7.5m in diameter, with the larger lower rings split in half vertically to simplify transportation. Once assembled, the concrete rings are post-tensioned vertically. Enercon has recently opened a dedicated plant to produce these precast concrete segments in Magdeburg, Germany. Enercon proposes an in-situ concrete solution for towers standing above 113m high, although no information on this is available at the time of publication.

GE Wind<sup>[5]</sup> is currently investigating the viability of hybrid concrete and steel pylons. A 100m tall prototype constructed in Barrax, Spain, features in-situ, post-tensioned concrete rings for the bottom 70m and a steel tube for the top section. The concrete section, which uses diameters up to 12m, is post-tensioned vertically with the cables running inside the tower, but external to the concrete wall. Again, a conventionally reinforced section with wall thicknesses of 350mm is used. The steel section is split into five sections, each weighing a maximum of 70 tonnes, with a maximum diameter of 5.7m.

A joint venture between the two Dutch companies Mecal and Hurks Beton<sup>[6]</sup> has produced a design for a 100-120m concrete-steel hybrid tower which is the subject matter of several written papers. The solution is similar to the GE Wind hybrid tower, in that it uses post-tensioned concrete, with the tendons inside the tower but external to the concrete section for the lower concrete section and a steel tube for the top section. However, the design makes use of long and narrow precast concrete elements rather than in-situ rings. Again, these elements are conventionally reinforced, with wall thicknesses of 250-350mm.

Clearly, Enercon believes that the precast ring segment solution is economically viable for heavier turbines for large towers. Indeed, the company has invested heavily in a production plant and is producing a stock of segments. Mecal and Hurks Beton<sup>[7]</sup> also believe that a concrete/steel hybrid tower is economically viable, focusing on whole-life costing for a wind farm and suggesting that although the initial investment in the hybrid tower will be greater than a steel tower, the returns will be greater because the tower is taller and generates more power.

As of August 2006, Nordex is offering concrete/steel hybrid towers for hub heights of 120m. Previously, it used solely steel towers but has recognised that concrete offers a relatively inexpensive alternative<sup>[8]</sup>. The solution comprises a 60m length of modular steel in three sections on top of a concrete tower produced in different lengths to provide hub heights between 100m and 120m. This involves the use of locally supplied materials and ensures an optimum turbine height to make the most of prevailing conditions. Nordex also recognize that this approach offers logistic advantages as the restrictive steel diameters normally applicable during transportation do not apply.

## 1.5 Background design considerations

Design concepts have been developed involving the use of concrete for wind towers, with the aim of achieving cost competitive and practical solutions for UK conditions. During the evolution of these concepts, information has been published on a number of other European designs that are currently available or under development. In the structural concepts set out here there are, unsurprisingly, some features shared with these other designs. The process has been to develop a synthesis of ideas and concepts arising from a fundamental consideration of the requirements and opportunities by the study team. It is hoped that this will point to some new directions and, at the very least, confirm and highlight important existing solutions which are worthy of greater consideration and application in UK practice.

Design solutions for offshore and onshore wind pylons have many similarities. Whilst some of the design and production thinking and subsequent development experience could be interchangeable, there are nevertheless some profound differences (see Section 7). One obvious difference is that offshore structures are subjected to additional loadings from waves and currents and to generally more aggressive conditions. Furthermore the construction and operating regime offshore is considerably more severe and hazardous. Specialist heavy plant needed for work offshore is subject to serious and, to some extent unpredictable, disruption from bad weather.

Early wind farms and turbine technologies were developed in the more benign conditions prevailing onshore. To date, concrete has been used much more widely in onshore wind energy structures than in offshore wind farms. Foundations for onshore wind towers are already predominately constructed using reinforced concrete, either as gravity bases or for

caps over piles. Only a limited number of wind pylons worldwide have so far been constructed using concrete, and these have been onshore. In the UK, examples of any size are restricted to one or two large towers for early prototypes.

The overwhelming majority of wind towers constructed to date have been built using tapered steel tubes formed from seam welded rolled plates with flanged bolted connections at the terminations. Taller towers were built up from separate lengths determined by transport and lifting constraints. For the larger towers specialist transporters are required to carry the tower sections from the fabrication yard and maximize the ruling diameter of the tube within the highways loading gauge. This has generally limited maximum steel tower diameters to 4.5m. However, it is understood that work is underway to develop segmented designs to overcome this limitation. This will require the introduction of costly bolted joints into the thickest and most heavily loaded sections of the tower.

Tall concrete towers and chimneys have a long and successful history and, whilst there are good reasons why steel towers have been the dominant solution to date, issues associated with increasing height, diameter and loading tend to point towards the use of concrete tower designs providing alternative, and potentially more competitive, solutions for future wind farms.

It would seem that the onshore industry is moving to a position where there could be substantial progress on the widespread use of concrete towers. Since in situ concreting is currently utilised for all onshore sites, logistically it would not be a big step to use slipforming. This is a particular in-situ technique which is entirely crane-independent. It can be used in conjunction with precast concrete or steel elements prefabricated off-site, to provide an efficient way of overcoming transportation limitations that would otherwise arise with the very largest elements such as structural towers. Slipforming can be used to construct tapering towers of any height desired.

The outcome is that the introduction of concrete-related construction techniques into the pylon element of towers, either in lower pylon sections or over their entire height, is a relatively simple and logical design step.

## 1.6 Towards more competitive concrete design solutions

Concrete wind tower solutions must be cost competitive with alternative and existing design options. For typical wind tower heights of 60-80m constructed to date, it is difficult to achieve designs and construction approaches where the lower specific cost of concrete as a material offsets the required increase in material quantity and weight. Even by adopting radical design approaches to minimise the thickness, and therefore the weight, of concrete towers, this approach is still likely to be significantly heavier overall than a steel design. As construction of next-generation wind farms with towers up to and beyond 100m high comes into closer focus, and given an expanding programme of construction, a number of factors make concrete an attractive design option for delivering large diameter pylons at acceptable cost.

An increase in tower weight may cause a number of significant effects. Beneficially, the inherent weight and stiffness of concrete towers can offer improved fatigue and dynamic performance levels and may also improve the efficiency of the foundation in resisting overturning forces. By careful attention to the distribution of weight over the height of the tower, the potentially adverse effects of this weight on the dynamic characteristics (natural frequency) of the tower can be minimised. The ability to tune the stiffness relatively easily by adjustment of the lower profile and thickness of the tower shell can more than offset any disadvantages.

Adversely, there may be a need to use larger, more powerful plant both for transportation and for construction, both of which are less readily available and more expensive. Ideally the optimum size of crane for erection should be determined by the nacelle weight (typically in the range of 70-150Te depending on the turbine rating). These issues may be more easily resolved by using in-situ concrete techniques (including those mentioned above) or precast concrete solutions that lend themselves to being split into a greater number of segments, or combinations of the two. While an increased number of segments might result in an increased number of transport movements and some increase in construction time, this approach may offer a cost-effective solution to site constraint challenges.

Fundamental characteristics of concrete in its freshly produced state are its plasticity (mouldability) and relative tolerance of handling. These make it extremely adaptable to a wide range of construction methods and to the production of complex or curved shapes. A variety of in-situ methods are available in addition to precast solutions. If hybrid concrete solutions (the combined use of precast and in-situ concrete) are considered, the adaptability of solutions increases even more.

The characteristics of concrete as a high performance structural material are of course well demonstrated in the huge inventory of major and complex structures around the world, both onshore and offshore. Given that the broad material factors are favourable to durable and economic structures, there is still clearly a need to consider carefully all the details affecting the key life cycle stages, in order to ensure the realisation of maximum economy and competitiveness with alternative materials.

## 1.7 Aim of this document

The aim of this study is to encourage the development of concrete wind tower solutions and to illustrate how the benefits of concrete construction can be realised more fully by the wind industry. By focusing on key issues pertaining to wind tower fabrication, the intention of the document is not to propose definitive solutions, but rather to highlight practical methods and technologies that, through optimisation, could lead to competitive solutions.

Conceptual configurations are presented for both onshore and offshore facilities, along with design philosophies and construction methodologies for concrete wind tower solutions. These concepts have been arrived at independently by the authors of the report and, perhaps not surprisingly, there are some similarities with the thinking of others working in this field. Whole life issues are accounted for, including fabrication, transportation, installation, maintenance, decommissioning, removal and disposal. Outline solutions for both concrete and steel are used for the assessment of their relative merits and viability.

# STUDY OF CONCRETE TOWERS FOR ONSHORE WIND FARMS

The onshore study was undertaken subsequent to the work on offshore wind farms. Some of the concepts touched on in the offshore study have been developed in more detail. There is inevitably some repetition between the studies, readers are advised to read both in order to get the fullest information from this report.

## 2 DESIGN PHILOSOPHY

### 2.1 General approach and configuration

The overall structural form selected for this study is a tapered tube, which has become the predominant form for wind towers over the past decade. This might be more fully characterised as a smoothly tapering, solid walled, circular section tube which can provide the following properties easily by virtue of its form:

- The weight and strength profiles of the cross-section follow the general pattern of that required by the function. Due to the taper, the weight per metre height reduces with increasing height, giving more favourable dynamic characteristics, as does cross-sectional strength, which matches the general pattern of overturning and shear forces.
- The circular form is efficient for a structure which can generally be loaded fully from any compass direction.
- Good appearance (particularly with careful attention to taper and proportions).
- Good aerodynamics.
- Provides sheltered internal space for vertical access for maintenance and cabling.
- Minimises surface area and edges open to aggressive weathering and corrosion.
- Is very well suited to concrete technology.

The choice of form may seem obvious but it is perhaps worth recalling that there is a long history of tall lattice towers for various purposes, including the traditional agricultural wind pump. In recent years lattice towers have been used in China for modern wind turbines. Some early consideration has been given to lattice or perforated tube structures in these studies as they might conceivably offer some benefits, particularly in the upper middle and top zones of the tower. However these have not been explored further.

Within the general constraints of the selected tapered tubular form, the key area of the design philosophy is flexibility of the solution. Each wind farm site is different and each project will have its own set of constraints and problems. Flexibility is thus needed at various levels of design, from overall configuration through to main strength and stiffness design, right down to key details.

At the global structural level, flexibility can be provided by a framework of related and alternative structural configurations. By fitting into the overall outline envelope of the tower, this will allow individual project designs to be more closely tailored to the circumstances of the project and thereby facilitate more cost-effective outcomes.

As shown in Figures 1.1 to 1.4, the approach involves notionally splitting the tower into three broad zones:

- Upper zone
- Middle zone
- Base zone

These are chosen to mirror different zones of design and construction constraints over the height of the tower. The extent of the zones is not fixed, so that the design concept has a sufficient degree of flexibility to cope with the changing constraints and design drivers of future wind farms.

One or more construction types for each of the zones are considered (in the following sections). Typically these are:

- The upper zone – *Precast concrete rings capped by a steel fabrication comprising the turbine yaw ring/nacelle bearing platform within a tapered steel tubular section*
- The middle zone – *Precast concrete segmented or monolithic rings*
- The base zone – *In-situ concrete or precast concrete segmented rings*

Alternatively, for in-situ slipform construction over the full height of the tower, the zoning has less apparent significance, but may still provide a useful way of characterising the different blends of design drivers over the height of the tower.

This framework is intended to facilitate practical conceptual design strategies. It may also point towards a structured approach to maintaining significant flexibility through the project preparation and procurement process for specific wind farm developments. The aim is to allow major component parts of the design to be readily adjusted during the project development programme to meet the changing market conditions. These take account of such factors as availability of materials, construction plant, fabrication facilities, contractors' preferences and risk perceptions, and possibly fine tuning to emerging load information relating to adjustments in turbine specification.

Given the major programme of wind farm development projected for the next decade and the implied steep rise in demand for fabrication and installation resources, flexibility is a desirable characteristic.

## 2.2 Design for construction

This section might also be called 'design for production', where construction or production encompasses fabrication, assembly and erection. The concept implies a design approach that involves significantly greater than normal attention being given to shaping the design of the final product to take account of these aspects of the construction process. It also implies that some design of the construction process itself is also involved. It is meant to put emphasis on an approach that can achieve significant process improvement and overall economy, particularly where there are potential economies of scale in terms of the numbers of units to be produced within particular projects or in the market at large. This opportunity is surely there, given that many currently planned wind farms may contain 30 to 150 units and the total future market implies the construction of many hundreds of units. It is perhaps helpful to draw attention to this concept for the general construction industry, where so many projects are essentially prototypical, although paradoxically by the nature of its business the precast concrete industry is very used to the mass production of standardised components.

In its broadest sense the concept involves an interactive and challenging approach to the values put on other design criteria. For instance, in relation to particular functional performance, it might involve critical examination of the trade-off of some loss of performance against production economy. Such an approach can usually often lead to better outcomes all round, particularly if it is applied to all levels of the design, from the overall configuration of the tower and major component segments through to all the key details.

## 2.3 Design concepts

The various overall configurations and design concepts for towers and details illustrated in this report have been developed in the light of the above design philosophy. They are discussed further in Section 3. Illustrations shown are indicative only and would require significant further engineering attention for realisation.

# 3 DESIGN

## 3.1 Indicative designs

Indicative designs and details for onshore concrete towers are illustrated in Figures 1.1 to 1.10. The two configurations selected for this study as representative of current and near-future scenarios are:

- 70m high tower; 2MW Turbine; 39m blades/80m rotor – Figure 1.1
- 100m high tower; 4.5MW Turbine; 58.5m blades/120m rotor – Figure 1.2

The near-future scenario is intended to cover the trend towards taller towers and/or larger turbines already well underway on some European onshore sites, where towers of 100m plus are considered to be cost-effective because of the better wind climate and therefore productivity. Interestingly the transition in height between current and future scenarios appears to require a step-change for steel towers in fabrication method and technology, and approach to transportation. Overcoming these constraints implies some relative increase in the cost of steel towers against concrete towers and therefore appears to shift in favour of concrete towers.

The figures indicate the type of concrete construction that is considered to be most appropriate for the different zones. These are:

- Upper and middle zone: Precast prestressed concrete
- Base zone: In-situ concrete, precast concrete or hybrid of the two
- Foundation zone: In-situ concrete

There is also a strong case for in-situ construction of the whole tower using the slipform method. Slipform is a continuous casting technique in which formwork is steadily moved upwards on screw jacks at a rate which allows the concrete placed in the top of the form to set sufficiently to support itself before emerging from the bottom of the rising form.

The overall design approach is to achieve best overall economy by matching construction process carefully to the particular needs and characteristics of each zone.

The taper profile of the tower is kept simple. For the 70m tower a uniform taper has been considered; for the 100m tower a bi-linear taper, with a more marked taper in the base zone giving a better fit to the strength and stiffness requirements. It is possible to achieve an even better fit by using a multi-linear taper, which does not necessarily introduce significantly greater production complexity if the taper within the height of the individual precast units is kept uniform.

A 'zonal' definition of the tower structure is given earlier in Section 2. From this perspective the idea of matching the type of construction to different zones points to the possible use of other materials for certain zones, in conjunction with concrete for others. One such hybrid configuration is shown in Figure 1.3 where the combination includes:

- Foundation, base and middle zones – *concrete*
- Upper zone – *steel*

The rationale for this configuration might be that, in the circumstances where a full concrete tower was competitive, it could provide a cost-effective way of tuning the dynamics of the tower (where weight reduction at the upper level is likely to prove beneficial in this respect). It might also provide a way of utilising available fabrication and erection resources to best effect, particularly for a major wind farm development where the pressure on a particular resource might become critical to construction programming.

Additionally this configuration provides a possible way of extending the height of present steel tower designs, without incurring the greater fabrication and transportation difficulties that are likely to arise from an all-steel tower design.

## 3.2 Foundations

Foundations for onshore wind towers will generally involve the use of a significant amount of reinforced concrete. Typical foundation arrangements for different soil conditions are shown below.

SOIL CONDITIONS	FOUNDATION TYPE
Good rock close to ground surface	Reinforced concrete (RC) base with rock anchors or bolts
Firm ground and underlying soils	a) RC gravity base acting as a spread footing
	b) RC base with piles/tension anchors
Weak or loose soils to depth	RC base with piles

Bases will generally be circular or polygonal (hexagonal/octagonal) in plan shape. Piles may be steel or concrete. The stiffness and dynamic behaviour of the foundation system is likely to be of concern, particularly in weak and loose soils.

Indicative weights of tower and nacelle in relation to the foundations are shown below.

WEIGHT in Tonnes	CONCRETE TOWER		STEEL TOWER	
	70m High 2MW	100m High 4.5MW	70m High 2MW	100m High 4.5MW
Tower Head Mass (THM) Inc. Rotor, Nacelle –gear box, generator etc.	105	220	105	220
Tower stem	450	1050	135	240
Foundation Allowance for base and piles	1400	3000	1500	3100
TOTAL WEIGHT	1955	4270	1740	3560

These figures are approximate and can be influenced by many variables between sites and systems. Foundation design is strongly driven by the large overturning forces that are fundamental to this type of Wind Energy Converter (WEC) system. In this respect the additional dead weight of a concrete tower as compared to a steel tower is likely to prove beneficial for foundation design in counteracting the vertical tension resultant.

### 3.3 Tower elements

The tower shaft may be split into a number of different sections for the purposes of strength and stiffness design, fabrication and erection. The possible types of construction featured in this study and their likely zonal application have been indicated in Section 3.1. This shows how various combinations of in-situ, precast, and hybrid concrete/steel construction might be applied, thereby allowing optimisation for different physical and development circumstances.

The use of precast concrete units for all three zones of the main shaft is an important option. A possible outline arrangement for such units is shown in Figures 1.4 and 1.5 for 70m and 100m high towers respectively.

The units may comprise a number of segments (2, 3 or more) to complete a ring, or whole ring units (cast as one unit) according to the ring section diameter and to the weight of individual units, all to take account of ease of transportation and handling. The wall thickness of units/ring sections may be varied between different zones and possibly within the separate zones. Similarly, concrete strength may be varied to achieve an optimum balance between the various cost drivers and physical constraints.

The construction sequence for an all-precast tower as shown in Figure 1.6 is described further in Section 3.7.

#### 3.3.1 Base zone

Generally in-situ concrete is required for foundation construction (Section 3.2). The construction of the base zone of the tower using in-situ concrete would not require the deployment of substantially different resources, apart from the particular formwork system for the base zone of the tower shell. Wall thicknesses typically in the range of 350-400mm plus would be vertically prestressed. This wall thickness is needed for strength. Thickening the wall even further in this zone may provide an efficient way of tuning up the overall tower stiffness since, amongst other things, the additional mass here has very little effect on the natural frequency of the structure and can in fact provide a useful added compressive load on the foundation.

Prestressing tendons could be accommodated within the wall thickness if desired and as such could be either bonded or unbonded. The overall construction operations have quite similar logistics and do not incur heavy additional costs in this respect.

Alternatively, the use of thick walled (300-400mm) precast concrete segments can provide a solution. These would be conditioned in size for transport to the site, and might have a width of 3-3.5m and a length (height when erected) of 12-18m. They would probably be best erected in-place before joining with in-situ poured concrete stitches to form a monolithic ring shell. Such joints could be conveniently made as wide joints, with projecting reinforcement from the precast units interlocking within the joints.

In either case the base zone construction in concrete can easily accommodate the local details (doorway etc.) for access to the tower. The design can be easily adapted to provide the base support to an upper steel tower as a hybrid solution.

A hybrid design may offer an immediately attractive solution for those projects with towers above 80-90m height, which are already essentially committed to the use of steel towers. Such an approach could avoid the step change in steel plate thickness required for the shell in the base zone, and thereby avoid the additional fabrication and transportation difficulties that may be experienced with the use of the heavy large diameter steel tower shells for such towers.

#### 3.3.2 Middle zone

Weight minimisation of the middle zone upwards is key to achieving a cost-competitive solution for a full-height concrete tower design.

For a given outline profile of the tower, the direct variables affecting the weight of the tower shell are effective concrete density (i.e. the density of the concrete reinforcement composite) and wall thickness. For the present study the use of lightweight concrete (using special manufactured aggregates) has not been considered in any depth. The unit weight (density) of concrete considered for structural design purposes is relatively independent of strength and for present purposes has been taken as 24 kN/m<sup>3</sup>, which is typically used for reinforced concrete with moderate levels of steel bar reinforcement.

The wall thickness is taken to be uniform for individual units (except locally at prestressing tendon anchorage points on certain units only). Various drivers include structural strength, stiffness, local stability and durability requirements which define minimum concrete cover to steel reinforcements or otherwise unprotected steel prestressing ducts and strand.

In the middle zone upwards the minimum wall thickness may be determined by the 'concrete cover to reinforcement' requirement rather than by the necessary strength and stiffness. This becomes more critical as the design strength class of the concrete is increased.

It is considered that even by using only a single centrally placed layer (two-way grid) of normal steel rebar, but taking account of realistic placement tolerance even with factory production, it will not be practicable to achieve sufficiently reliable durability for a long life tower structure (50 years plus) in an aggressive external environment with a wall thickness of less than 150 to 175mm.

Overcoming the restrictions imposed by the normal concrete cover requirement allows the use of thinner concrete walls. This could be important to the minimisation of the weight of the middle and upper zones of the tower and the cost of the tower overall.

Various techniques are available which can overcome these restrictions. These are discussed further, along with a possible design solution, in Section 3.5.

### 3.3.3 Upper zone

The design logic of weight minimisation could be even more relevant to the upper zone. It is envisaged that the thinnest practicable shell elements will be used here, subject of course to the provision of sufficient resistance to the maximum cyclic wind effects. For present purposes the minimum wall thickness has been set at 100mm.

The top of the tower has to support the turbine nacelle and yawing bearing. For present purposes it is considered that this connection will be provided by means of a 'turbine spur'. Notionally this will be a two metre high section of steel shell matching the out tower profile, within which there is a transfer platform supporting the yaw ring, and through which there is a central access hatchway into the nacelle. This fabrication would be fixed to the head of the concrete tower by a ring of stressed bolts.

## 3.4 Prestressing of the tower

The concrete tower is designed as a vertically prestressed tapering tube. A circumferentially uniform pattern of prestressing forces is to be applied at a magnitude which changes with height (in a stepped pattern) according to the forces that the tower has to resist. This will provide a circumferentially uniform vertical compressive stress sufficient to avoid vertical tensile stresses in the tube walls under normal design loading. This vertical prestress is also important to the shear strength of the tower tube.

Prestressing provides an efficient and economic means of achieving good all round strength with excellent durability, fatigue and dynamic performance. It also provides a straightforward and positive means of unifying the separate rings of a precast concrete solution so that they act as a monolithic tower structure. With careful design and detailing, prestressing can also provide solutions to the problems of handling units for erection and maintaining adequate strength in the partially completed tower during its construction. This can be further appreciated by reference to Section 3.7 and Figures 1.6 to 1.8.

The choice of general technique and configuration lies between bonded and unbonded tendons, and internal or external placement. In general, unbonded external tendons are favoured in this onshore study for their simplicity and ease of installation although bonded or unbonded internal tendons could also provide a satisfactory solution, particularly for the thicker sections of wall and especially in the base zone.

External prestressing involves the placement of the prestressing tendons (cable or bars) outside the structural section which is to be prestressed, and therefore removes the need to accommodate the tendons and any ducts within the thickness of the shell wall. The stressing force is imposed through an anchorage detail that transmits it back into the section. An anchorage is of course required at each end of the tendon. The tendon is not continuously bonded to the section in question although it may be restrained back to it at discrete points along its length. In the case of the tower, vertical prestressing of the tower shell may be applied by a circular array of tendons placed within the concrete tower shell close to its inside face.

Crucially the use of external prestressing permits the use of thin-walled concrete sections for the tower, since wall thickness is not governed by the need to accommodate tendons internally. Another important advantage is that installation of the tendons at the various stages of construction can be more easily achieved.

It might be argued that the external prestressing tendons will be more at risk from corrosion. There is long experience of the use of external tendons on major bridge structures. Whilst care always has to be taken to ensure the durability of highly stressed components, particularly in the anchorage areas, there is no reason to think that this represents an unusual or insolvable problem. The tendons would be protected by factory installed corrosion protection systems, including inhibitors, greasing and heavy plastic sheathing. Anchorage areas will be accessible for proper finishing, capping and inhibiting grease injection. Additionally, unlike internally located prestressing strands, the external tendons would be visible, easily inspected and even replaceable. Location within the internal tower shaft provides a sheltered and relatively benign environment within which humidity and condensation could be actively and economically controlled as a further precaution.

There are further advantages from using external unbonded prestressing. There will be even higher fatigue tolerance of dynamic loading because the cables will experience an overall averaged and therefore lower stress range during load cycling, as compared with bonded cables which are subjected to rather higher more localized stresses. There will also be lower friction losses during stressing. The eventual demolition of the structure will be simplified, and the recovery of both the concrete and steel component materials for recycling will be simpler and cheaper.

Outline details for cable layout, anchorage and restraint are shown in Figures 1.6 and 1.8.



It is considered that some restraint of the individual unbonded tendons is required, linking them back to the tower shell. Figure 1.10 shows a simple detail that would provide such restraint. This restraint would provide some additional stability to the tower under accidental overload or high level impact as might occur during erection. It would also act as a safety measure during construction by restraining any whiplash movement should a tendon inadvertently fail due to overstressing during the stressing operation.

### 3.5 Thin walled shell units

The importance of minimising wall thickness to the economy of the concrete tower design has been discussed in Sections 3.3.2-3. This is particularly important when craneage is needed to lift large units into place. For a vertical direct load and /or overturning bending capacity, the tube wall thickness can be reduced by increasing the concrete strength class (it is considered practicable to increase this up to a compressive strength of 100N/mm<sup>2</sup> as required, and possibly beyond).

However there are limitations to the minimum thickness of conventionally reinforced concrete sections due to the need to provide a minimum thickness of concrete cover as explained in 3.3.2 and possibly from the accommodation of prestressing tendons. An approach to overcoming the latter limitation has been set out in Section 3.4. The concrete cover restriction may be overcome by the use of non-corroding reinforcement.

Some possible techniques and ways that these might be used are explained below:

- i) The use of non-corroding reinforcement would remove the need for thick cover (50-75mm) required for external or aggressive environments, and would allow cover thickness to be reduced to dimensions necessary to allow good penetration and compaction of the concrete around the reinforcement, and provide good bond strength and transfer of forces from the reinforcement into the body of the concrete. By limiting rebar diameters to small to medium range (10-25mm dia) cover dimensions could be reduced to 25mm assuming that the durability issue had been overcome.

Assuming the use of steel rebar, the options are epoxy coated, galvanized or stainless steel rebar. Both the coated bars (epoxy/galvanized) are susceptible to mechanical damage or local weakness of coating, and to consequential anodic corrosion which could limit their durability and reliability for long life structures. For the present study it is assumed that stainless steel rebar will be used where steel reinforcement is required in thin wall situations, or in other details where low cover is desirable or necessary for design reasons. It is generally accepted that stainless steel rebar can be used in conjunction and in contact with normal steel reinforcement within concrete members without any serious risk of 'cathodic/bi-metallic' corrosion problems.

It is important to note that stainless steel costs approximately five times more, weight for weight, than normal high tensile steel rebar. It is therefore vital to limit the use of such reinforcement to a minimum in order to achieve the potential economy of thinner walled sections.

- ii) Other techniques for achieving non-corroding reinforcement include the use of non-ferrous reinforcement in an analogous way to conventional steel reinforcement or by using significant quantities of chopped fibre as part of the concrete matrix. The former approach has not been considered any further here as such reinforcements are not in widespread current use with concrete and do not appear to offer significant overall advantages at present.

On the other hand the use of chopped fibre reinforcement concrete (FRC) is being widely used in various applications. Techniques and supply arrangements are well established with a significant international research effort continuing to achieve improved structural properties and performance for FRC. Suitable chopped fibre materials are certain polymers (polyesters/polypropylenes), stainless steel wire or arguably even normal steel wire. Fibre reinforcement can give considerably increased resistance to cracking and much greater toughness over plain concrete. At present FRC cannot be relied upon to provide reliable tensile strength to resist major primary structural actions.

The question arises as to what strength characteristics are needed for the concrete tower shell? The tubular form provides excellent vertical load carrying capacity and there is no primary need for tensile reinforcement for this purpose. Overturning bending of the tower will be resisted by the action of the prestressed concrete tube, as will horizontal shear and torsion forces about the vertical axis. Bending in the wall shell about the vertical axis and associated shear forces, and horizontal hoop forces, are generally likely to be very small from externally imposed forces. Such forces, to the extent that they are significant, are likely to be the result of strain induced loads from temperature, creep etc. It is considered that these secondary effects can be resisted safely by local reinforcement and the provision of a level of general toughness and crack resistance.

The effects of loadings from the turbine at the very top of the tower, particularly cyclic loadings, may require wall thicknesses greater than the minimum achievable. However moving down and away from the uppermost level, the stress levels from these loads will drop with the increasing section diameter, and may provide a zone of tower where these walled units provide an appropriate economical and useful design solution.

By combining the use of limited quantities of stainless steel reinforcement with the use of FRC it is considered that thin-walled shell units with the necessary structural properties can be economically constructed.

Fibre reinforcement is proposed as the most suitable material for alternative concrete reinforcement. Fibre reinforcement is to be used throughout the precast ring segments, but with all the steel reinforcement omitted over the central region

of the rings. The prestressed design of the concrete tower ensures that for ultimate limit states, no tension occurs in the concrete. Consequently the fibre reinforcement provides some general toughness and resistance to secondary effects such as thermal stresses. Bands of stainless steel reinforced concrete are located at the ends of each ring segment to provide extra toughness during lifting and handling and act as 'crack stops' down the tower. Figures 1.7 – 1.10 show the arrangement for a typical ring segment.

It must be emphasised that while this approach uses existing concrete technology to its limits, in essence nothing new is being proposed. The materials are well proven for the functions they perform. However, this approach could play an important part in achieving a precast concrete solution that can be both cost competitive and able to challenge the current steel solution.

### 3.6 Joints

These comments apply to the precast concrete solution or possibly to the joint between an in-situ concrete base and a precast middle/ upper section of tower.

Simplicity of connection and accuracy (and trueness) of level are the two key drivers for joint design. The simplicity of the connection will keep the formwork costs and on-site construction time to a minimum. Accuracy of level across the top of the joints is imperative in order to ensure verticality of the final complete tower.

Two basic types of joint are envisaged. One will be at a connection of the precast units where the prestressing strands terminate, the other will be at an intermediate connection of the precast units where the prestressing tendons are possibly linked to the tower wall but not terminated.

The joints will be provided with a simple mechanical connection such as stainless steel dowels to facilitate accurate engagement and assembly, to fix each unit's location immediately after placement and before overall prestress is applied. This takes account of the possibility that prestressing may not be applied until several units have been stacked up.

One possible concept for achieving a self-levelling joint involves the use of three local seating pads on each side of the joint to ensure verticality to within a few millimetres. The seating pads are envisaged as thin projections above the general joint surface that would be ground to a precise level to set the general thickness of the joint. The thin joint will be filled with epoxy resin. The method of application of the resin would need to be carefully developed to be weather tolerant and reliable. It may involve such techniques as injection or pre-placed mortar/ resin pre-placed impregnated tapes. Some of the stainless steel dowels would be made longer to act as locators to facilitate rapid acquisition and correct orientation of the incoming unit, and achieve fast connection of the joints in the difficult conditions on site.

It is important that simple jointing and connection methods are devised to facilitate straightforward and rapid erection. Indicative details are illustrated in Figures 1.7–1.10. These details are based on the use as far as possible of plain thin epoxy joints between units, with the units coupled vertically both individually and overall by prestressed bolting and tendons.

### 3.7 Construction sequence

A notional construction sequence for a precast concrete tower is illustrated in Figure 1.6.

The precast units will be transported to site as whole rings for smaller diameter sections and as ring segments for the larger diameter rings. Ring segments will be joined into a complete ring on site. Ring sections will be stacked up, either in place for the lowest heaviest rings, or into tower sections comprising three or four rings for lifting into place on the tower. Some limited stressing together of tower sections prior to lifting into place may be useful to assist with handling, or alternatively a special lifting cradle may provide a quicker and more cost-effective solution.

Newly erected sections of the tower would be stressed either by bolts/tendons connected to the underlying section, or by full length tendons emanating from the base anchorage. This would provide both the short term stability during construction and contribute to the permanent works strength. The aim would be to achieve an efficient pattern of curtailment of tendons and consequently applied prestress which was well matched to the design envelope of externally applied force resultants.

This approach to prestressing requires anchorage arrangements at a number of levels over the height of the tower. Figure 1.8 indicates a possible outline detail involving the provision of an annular ring beam formed inside the tower shell on selected units. The ring beam would contain vertical duct holes at regular spacing around the perimeter set to align with the planned tendon paths. This detail could provide anchorage to long tendons, short bolts, or act as a local duct for tendons continuing up the tower. The ring beam would require relatively heavy local reinforcement in accordance with normal practice for prestressing anchorages. This would probably be best provided by stainless steel bars in the form of welded cages, allowing cover to be minimised and thereby reducing the propensity for cracking and also of course minimising the additional weight of the ring beam.

The number of tendons, curtailment pattern, anchorage positioning, and so on are interlinked with the requirements for erection and construction as well as those for the permanent design. Careful design and planning at all levels of detail will be an essential part of producing an efficient and cost-competitive solution.

### 3.8 In-situ slipform construction

Precast concrete units offer a viable design solution for the whole tower, and also for the middle and top zones in combination with an in-situ concrete, slipformed base zone. Alternatively, in-situ slipformed construction for the entire pylon height offers some potential advantages, avoiding the need for transporting precast units to the wind farm site and the provision of heavy cranes. This could be particularly useful for sites in areas where access for very large vehicles is problematic. Whilst in-situ operations clearly involve the transportation of basic materials to site, this can be undertaken off critical timelines and does not pose special problems of vehicle size or load size. State-of-the-art mixing equipment such as volumetric truck mixers or mobile site plant can be easily used to deliver high quality concrete on site.

Minimum wall thicknesses, achievable without incurring special difficulties, are in the range of 150–175mm. Below this thickness, proneness to horizontal cracks due to slipform drag may become a problem. Certain minimum levels of steel reinforcement are also required to provide the necessary early support and strength. Thus the 'thin shell' concepts described in Section 3.5 do not apply to the same extent to in-situ slipforming. In general this is not likely to be a significant source of diseconomy, since cost and productivity considerations of heavy cranes do not apply to slipforming.

With regard to productivity and programme time, slipforming, by its nature, is a continuous 24/7 operation with output rates of four to six metre heights per day routinely achievable.

### 3.9 Cranes and lifting

A current feature of wind farm construction is the deployment of heavy long jib cranes to handle and assemble the large and heavy components or units. This may involve lifting from the transporter for preassembling of sub-units on the ground, and then lifting assembled units from the ground, or lifting direct from the transporter into place on the foundation or partly constructed tower. Such cranes are expensive, particularly if there are delays due to weather, supply or assembly problems.

Slipforming illustrates a technique which removes the need for cranes, at least for the tower construction itself. At present it would nevertheless be necessary to deploy a heavy crane for lifting the yaw ring/ nacelle/ generator and the turbine rotor either completely separately, or in a 'bunny ears' configuration with the nacelle.

A fundamental feature of slipformed tower construction is the use of the existing tower to provide the main load path to ground for the raising of the new construction. The tower also provides the main stabilizer/ lateral strength for the man/ materials lift mast. This approach, using the partly constructed tower as a major component of the 'temporary works', provides a possible pathway to greater economy and construction simplicity for the future, whether for lifting precast concrete units, nacelles or others.

It would be interesting to speculate on the form of devices using this approach. It is perhaps useful to note that there are features of a concrete tower that would seem to give greater scope and facility for accommodating such devices, compared to a steel tower. The greater wall thickness of the concrete tower can more easily accommodate the imposition of high local wheel or clamping loads, whilst the provision of embedded fixings for track-ways or masts are also less likely to cause stress raiser or notching problems, which could adversely affect fatigue strength and durability.

### 3.10 Structural analysis

The ultimate strength of the tower was determined from the loading at the turbine's maximum operating wind speed. The extreme design bending moment at the base of the 70m tall tower is 70,000 kNm and for the 100m tall tower is 210,000 kNm both with a load factor of 1.5.

The dynamics of the tower were assessed by calculating the natural frequency of the tower and comparing this to the 1P-range (single blade passing frequency). The range for the first natural frequency of the towers was found to be 0.4Hz to 0.8Hz for the 70m high tower, and 0.3Hz to 0.7 Hz for the 100m high tower, encompassing the variability of soil stiffness, concrete stiffness and turbine mass likely. This is similar to other such towers for wind energy converters. The dynamic load inputs into tower structures depend upon the characteristics of both the rotor/ generator characteristics, the tower/ foundation structural system characteristics and their interaction.

Within the 'turbine' system there are many variables under the manufacturer's control, including active control/ management algorithms, which affect its behaviour of, and therefore inputs into, the overall structural system.

At general concept stage it is not possible to take full or precise account of all this complexity, although a range of representative values for the major load effects have been considered. It is believed that prestressed concrete towers, particularly in the middle/ lower tower zones, will be less sensitive than steel towers in their critical design sizing to the variations between different turbines of similar rating. Exploring and determining this sensitivity is an important part of the next stage of work in developing economic concrete designs.

There is ample scope to tune the towers' dynamic performance both during design and during commissioning. During design the Young's modulus of the concrete, the foundation and in-situ base section geometry and mass, and the mass at the top of the tower can all be varied to produce the desired dynamic performance for the tower. Once constructed the mass at the top of the tower can be altered to tune the tower based on as-built testing. This might be useful during prototype development. The use of mass damping at the top of the tower in the turbine would also allow the dynamic performance of the tower to be tuned.

This ability to tune the dynamic performance of concrete towers, including the ability to tune the tower during operation, reduces the potential risk of adverse dynamic behaviour of the tower. It ensures that the concrete tower solution can be designed to avoid interference with the 1P-range and can be tuned to individual site constraints.

An assessment of the potential fatigue damage to the tower design over a 25 year design life was also carried out, with concrete performing favourably.

## 4 QUANTITIES AND COSTS

The early estimation of costs of innovative design solutions is often very difficult as, by the nature of the situation, little direct data is available to the designer. It requires considerable engineering design, construction and logistics planning to get to a point where high levels of assurance can be given on cost estimates. In the case of wind energy much of the commercial and detailed construction cost information is held by the wind turbine companies and to some extent the wind farm developers. It is understandably regarded as intellectual property which is carefully guarded and, if available at all, such information is usually very general with limited contextual supporting information. In this study we have based our judgement of costs on basic and comparative cost exercises using estimated quantities of the main constituent materials coupled with unit rates adjusted for the adverse or advantageous factors that are judged appropriate.

The costing exercise was undertaken on the two demonstration all-concrete design solutions (70m tall tower and 100m tall tower). Costs were calculated based on a worked-up cost per tonne for the installed tower (excluding foundations and turbine) of around £580/te to £600/te, and using the tower weights detailed in Section 3.2. Comparisons with estimated costs for equivalent 100m and 70m tall steel tower show that the demonstration concrete tower designs are at least cost competitive, with potential cost savings of up to 30%. In this respect it is considered that slipformed towers provide the greatest potential savings. These savings are postulated on the basis of a substantial design development process coupled with the construction and testing of some prototypical towers. They also assume that reasonable economies of scale are available from the size of the individual development projects and from some continuity on key features of the design between projects.

## 5 ONSHORE STUDY CONCLUSIONS

- The contribution of wind energy to the UK's supply of electricity is planned to grow substantially over the next decade, with the number and size of wind farm projects in process and being commissioned now starting to rise in line with these plans. Therefore the demand for turbine towers is also rising in both numbers and size.
- The wind turbine industry is looking for better solutions for tall wind turbine towers of 100m or more in height. This is being driven partially by the imminent release of a new generation of larger wind turbines with longer blades, as well as the reduction in the availability of unexploited 'favourably windy' sites which will drive the need to exploit less windy sites, with less advantageous topography.
- 100m tall towers are at the limit of existing steel designs and the installed fabrication technology needed to produce them. They also present serious difficulties for transportation of the lower steel sections for the taller towers.
- The trends towards increased size of turbines (rating, weight), tower height and therefore diameter and weight, and to larger wind farms all provide more favourable competitive opportunities for concrete towers.
- Concrete towers (100m plus height) have been used successfully elsewhere in Europe, particularly in Germany. These have featured both precast and in-situ slipformed designs, similar in general terms to some of the design options considered in this study.
- All the designs considered in this report involve the use of vertical prestressing. Various configurations, techniques and details have been proposed, based upon the existing state of the art.
- In order to achieve sufficiently competitive full height solutions which seriously challenge onshore steel tower designs in the UK, substantial design and development effort to optimise concrete designs is needed.

- Key issues for attention are minimising material content and structural weight, particularly in the middle and upper zones of the tower, whilst achieving construction simplicity with short construction times. Concrete technology and the material itself offer great flexibility for optimising the design solution for particular circumstances.
- Useful weight and cost savings in the middle and upper zones of the tower may be available from some development in the use of fibre reinforcement, as suggested in the report.
- The use of in-situ slipform construction methods provide an efficient way of overcoming the difficulties of transporting large tower rings/sections to site, and removes the need for the use of a large crane for the tower erection.
- The development of 'craneless' methods for the erection of the turbine (rotor) nacelle and rotor using lifting platforms climbing up the tower itself could offer further important overall economies. The concrete tower shell is well suited to supporting local concentrated loads that would be imposed by such devices.
- The design philosophy presented draws on concrete's flexibility and promotes an approach to a solution that can be adapted to suit the individual demands of each wind farm development, and thereby provide a more cost-effective outcome. The use of precast concrete, in-situ concrete and steel in various composite or hybrid configurations is allowed for.
- Exploitation of the durability and longer fatigue life of prestressed concrete towers could provide greater sustainability and long term economic benefits. With the tower service life extended to between 40 and 60 years, one or more turbine re-fit cycles could take place with minimal further expenditure on the tower, foundations and other infrastructure.
- Concrete solutions for a 70m and 100m tall tower are derived from the design philosophy. They show cost competitiveness with likely equivalent steel solutions. Costings indicate that there is a potential for savings of up to 30% over steel towers for taller towers (70-120m plus) supporting larger turbines.

## 6 FIGURES - ONSHORE WIND TOWERS

Figure No.

- 1.1 70m CONCRETE TOWER - Outline and indicative dimensions
- 1.2 100m CONCRETE TOWER - Outline and indicative dimensions
- 1.3 HYBRID TOWER - Arrangement with steel upper section
- 1.4 70m CONCRETE TOWER - Assembly from precast concrete units
- 1.5 100m CONCRETE TOWER - Assembly from precast concrete units
- 1.6 TOWER CONSTRUCTION SEQUENCE
- 1.7 ASSEMBLY OF RING UNITS INTO TOWER SECTIONS
- 1.8 TOWER SECTION JOINTS - Anchorage section and plain joints
- 1.9 RING UNITS - Reinforcement and segment joints
- 1.10 TENDON RESTRAINTS - Yokes to plain units

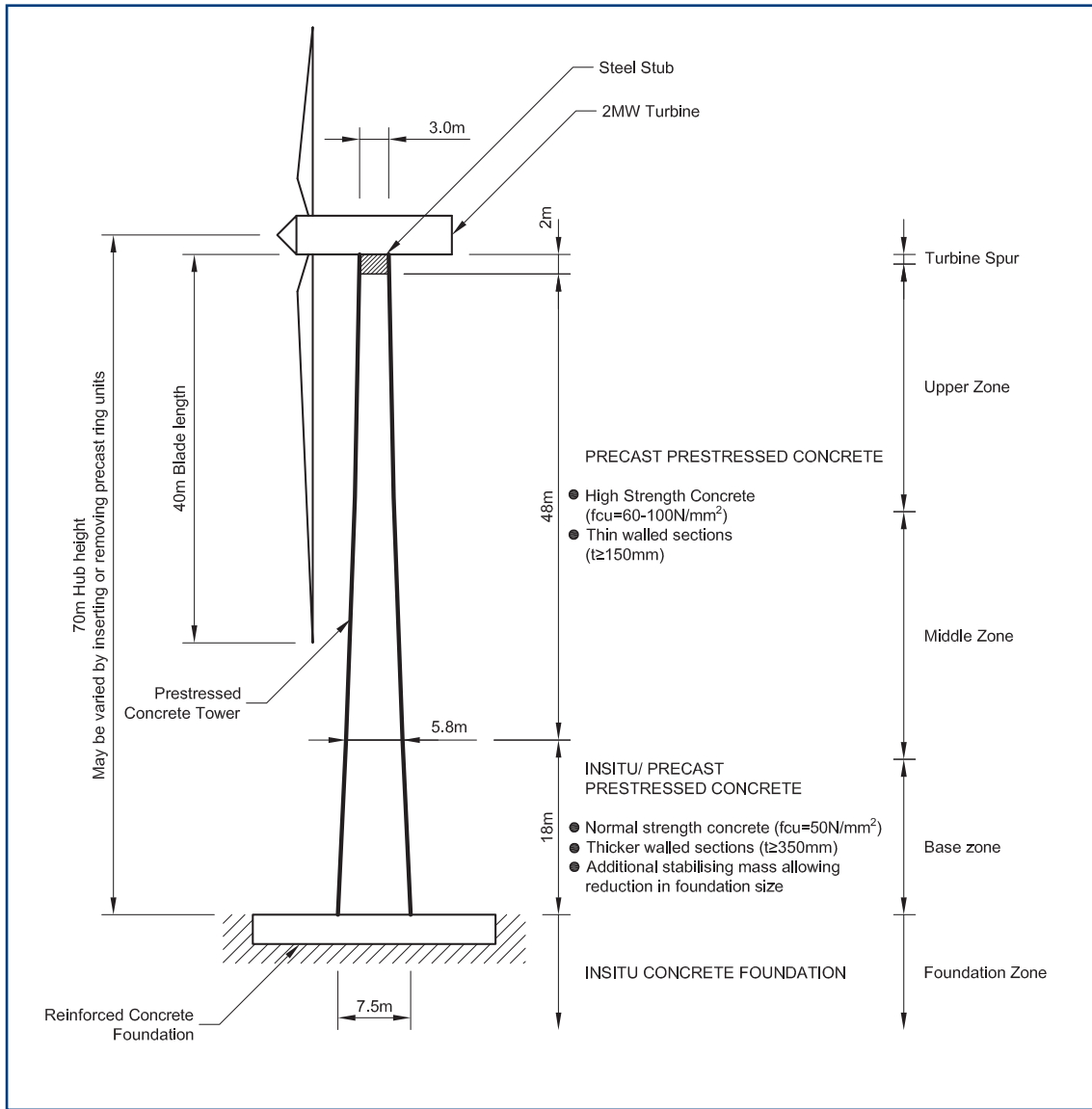

Figure 1.1  
70m CONCRETE TOWER - Outline and indicative dimensions

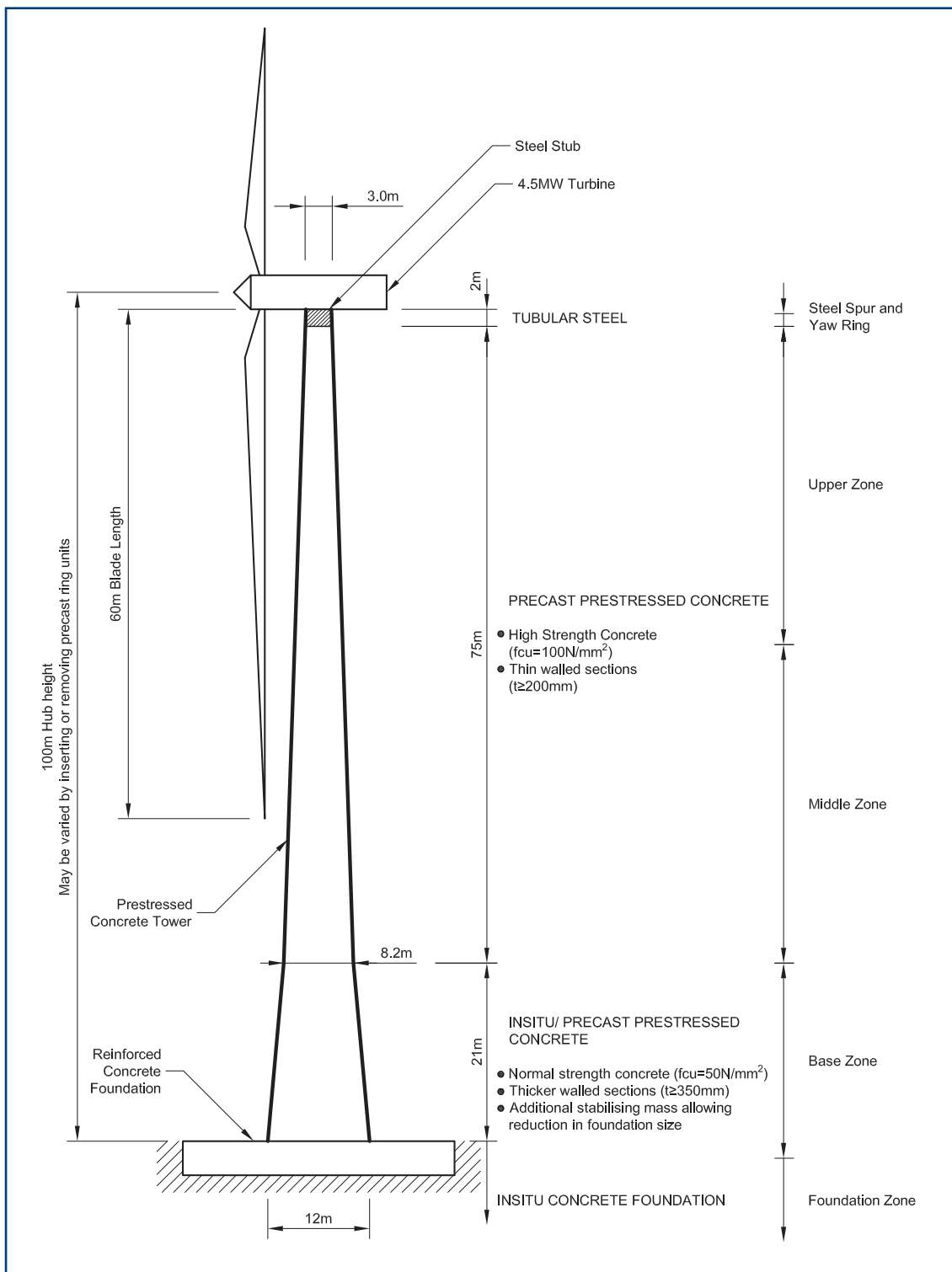

Figure 1.2  
100m CONCRETE TOWER - Outline and indicative dimensions

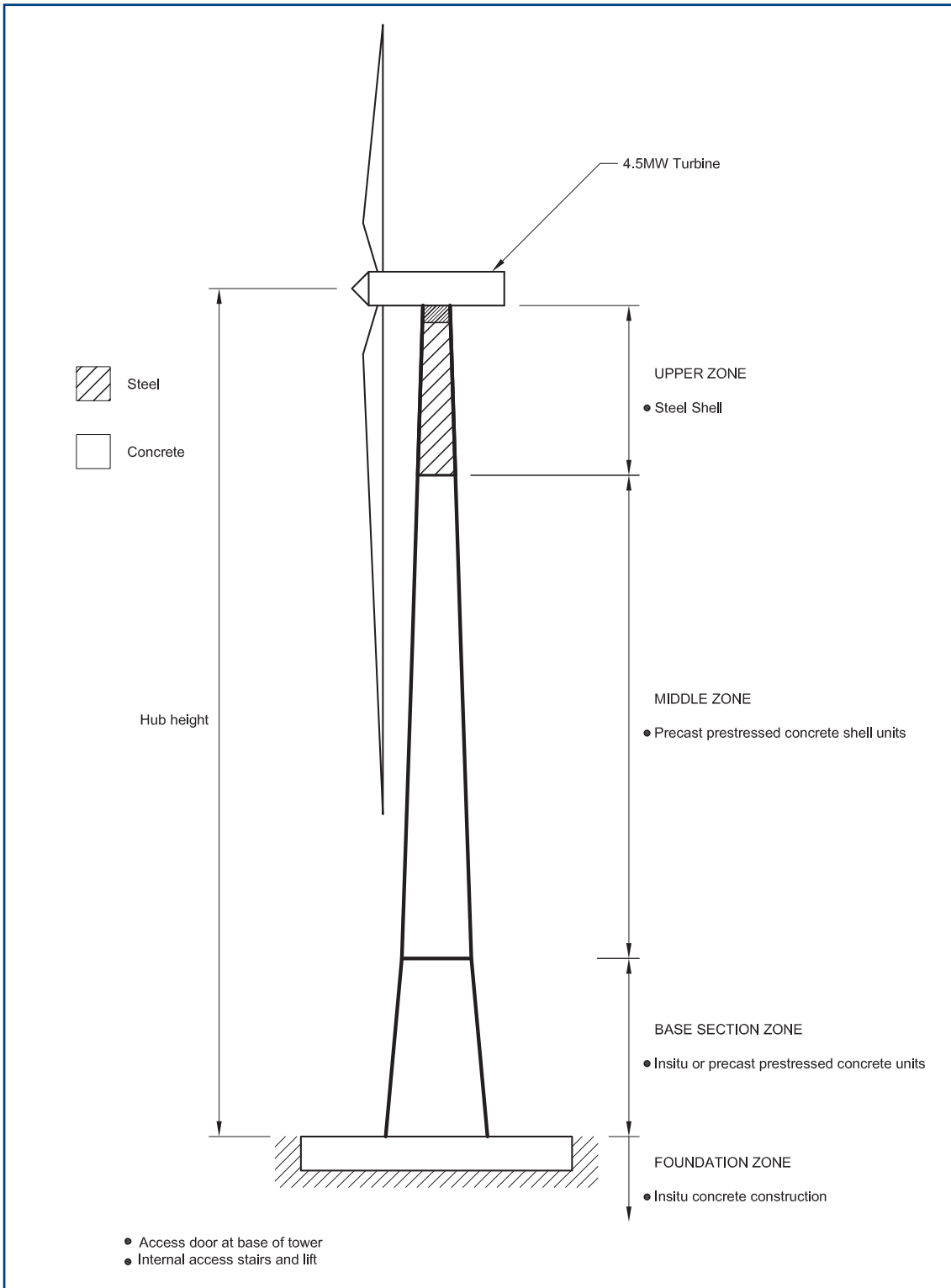

Figure 1.3  
HYBRID TOWER - Arrangement with steel upper section



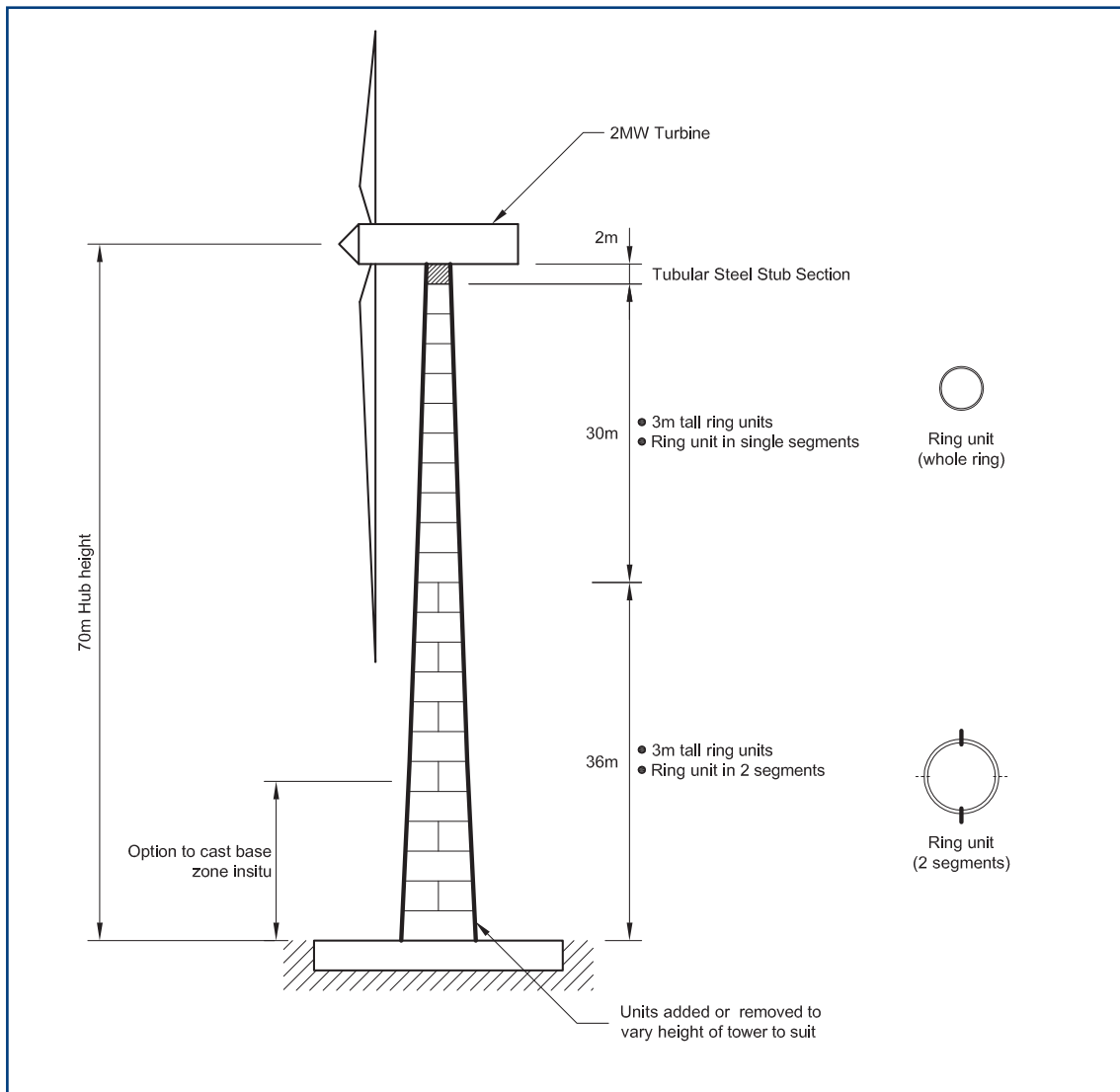

Figure 1.4  
70m CONCRETE TOWER - Assembly from precast concrete units

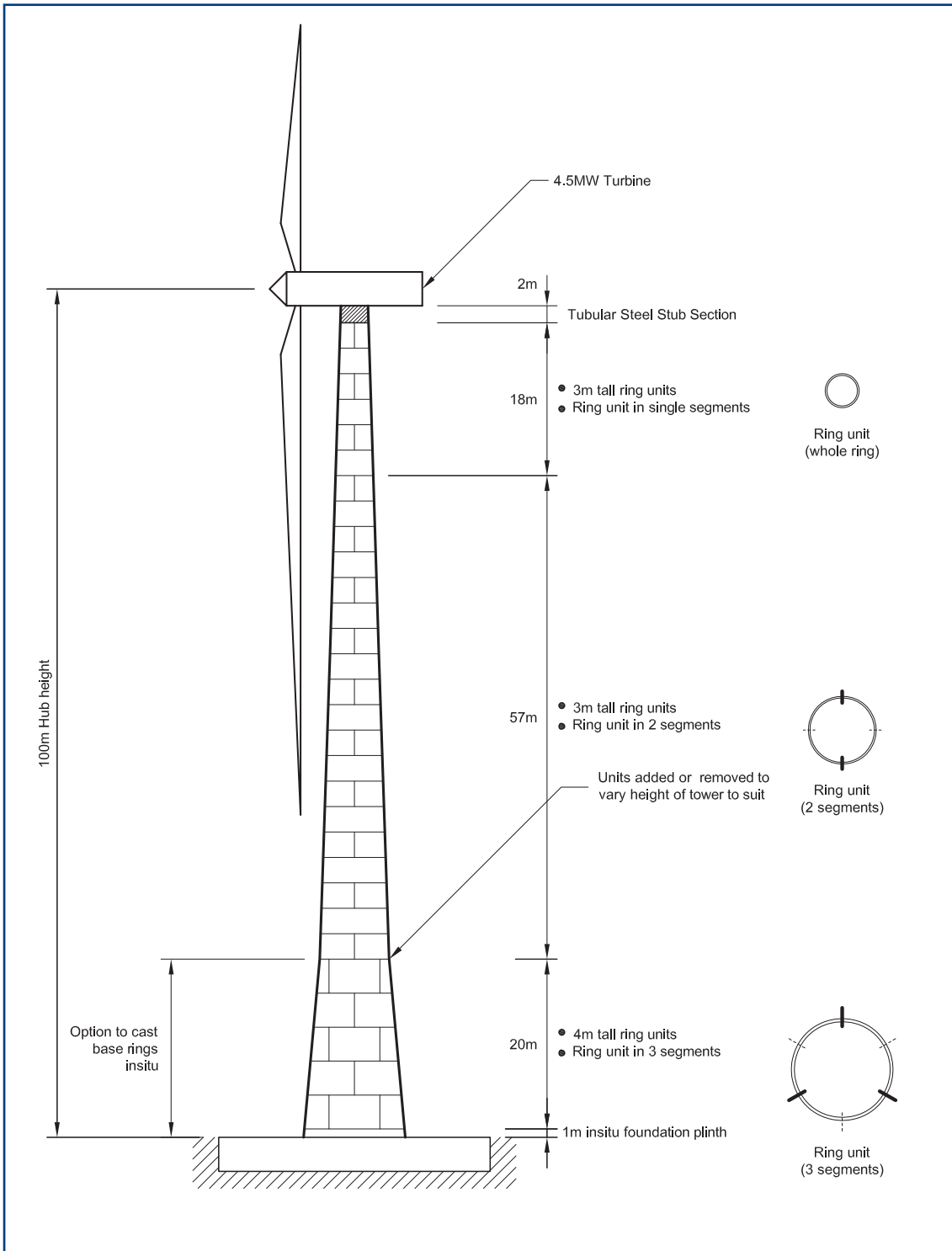

Figure 1.5  
100m CONCRETE TOWER - Assembly from precast concrete units

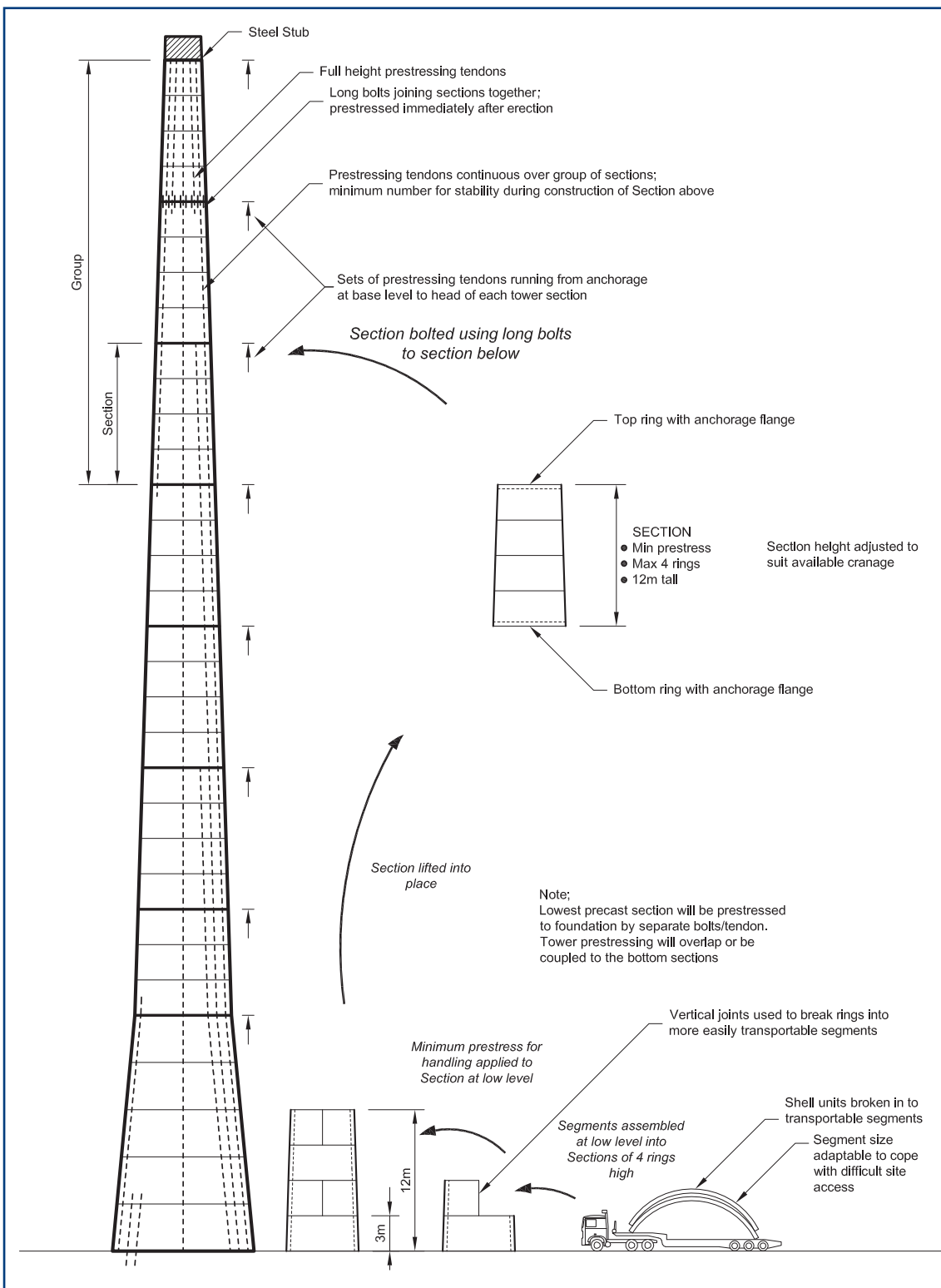

Figure 1.6  
TOWER CONSTRUCTION SEQUENCE

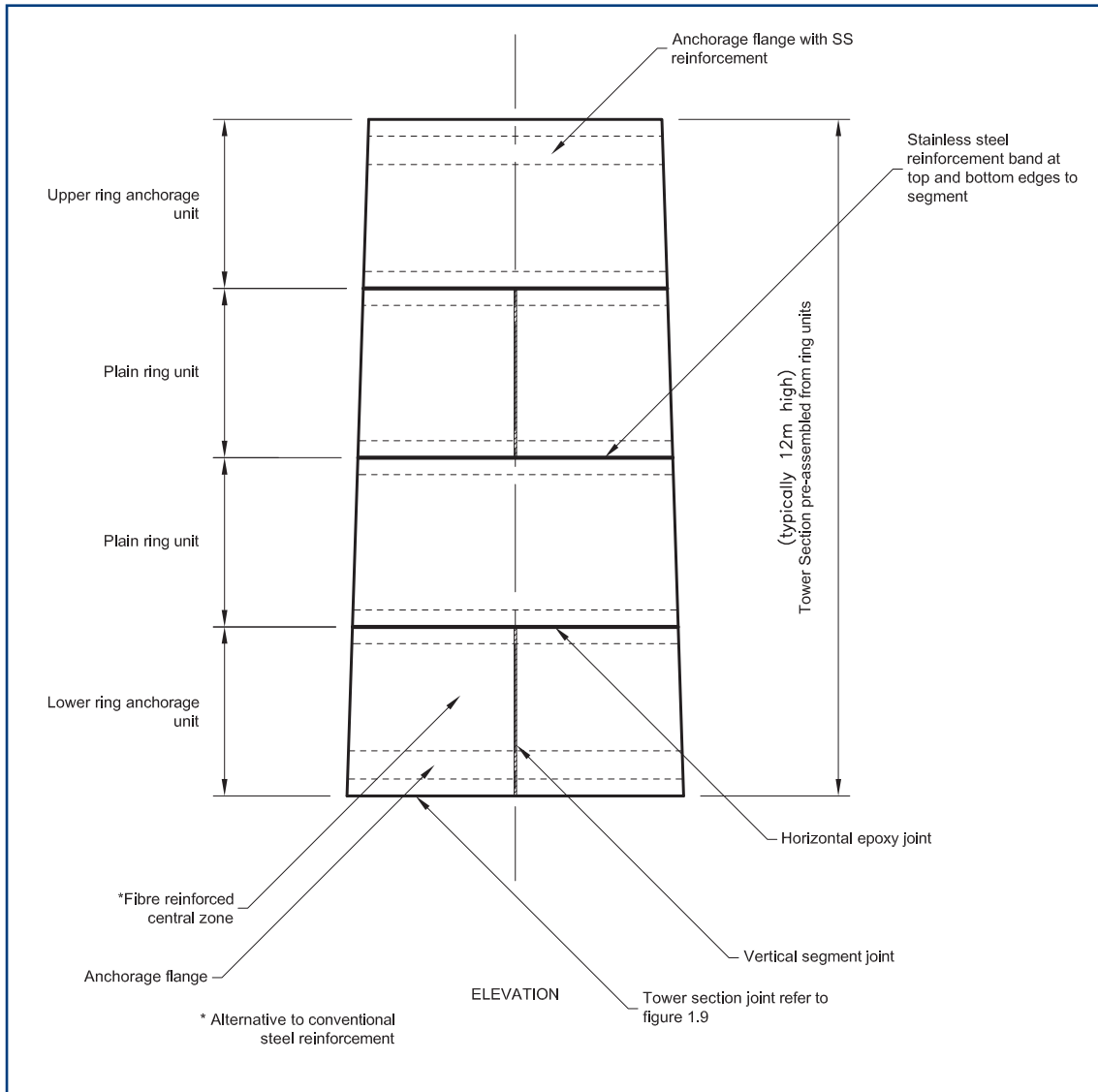
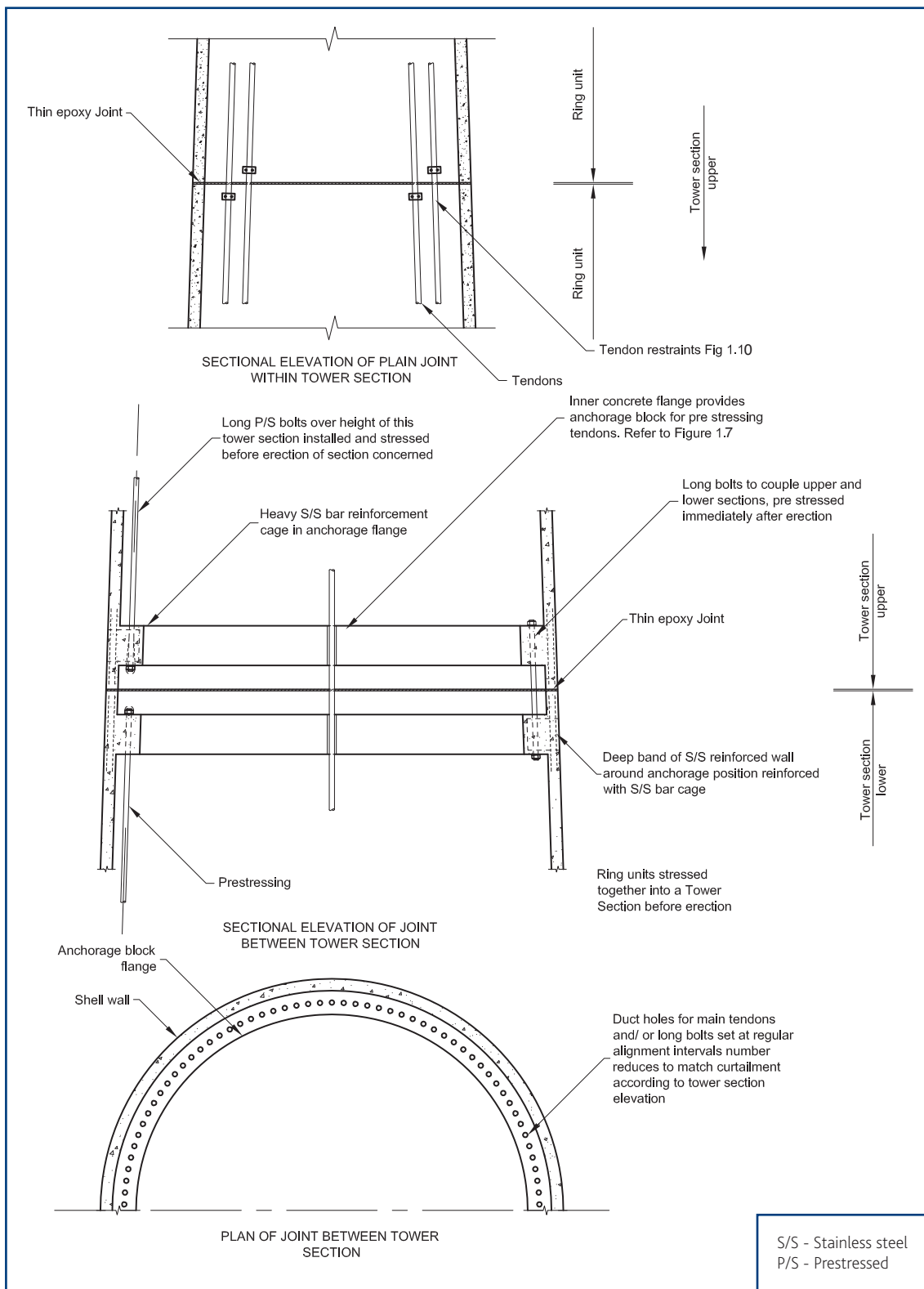
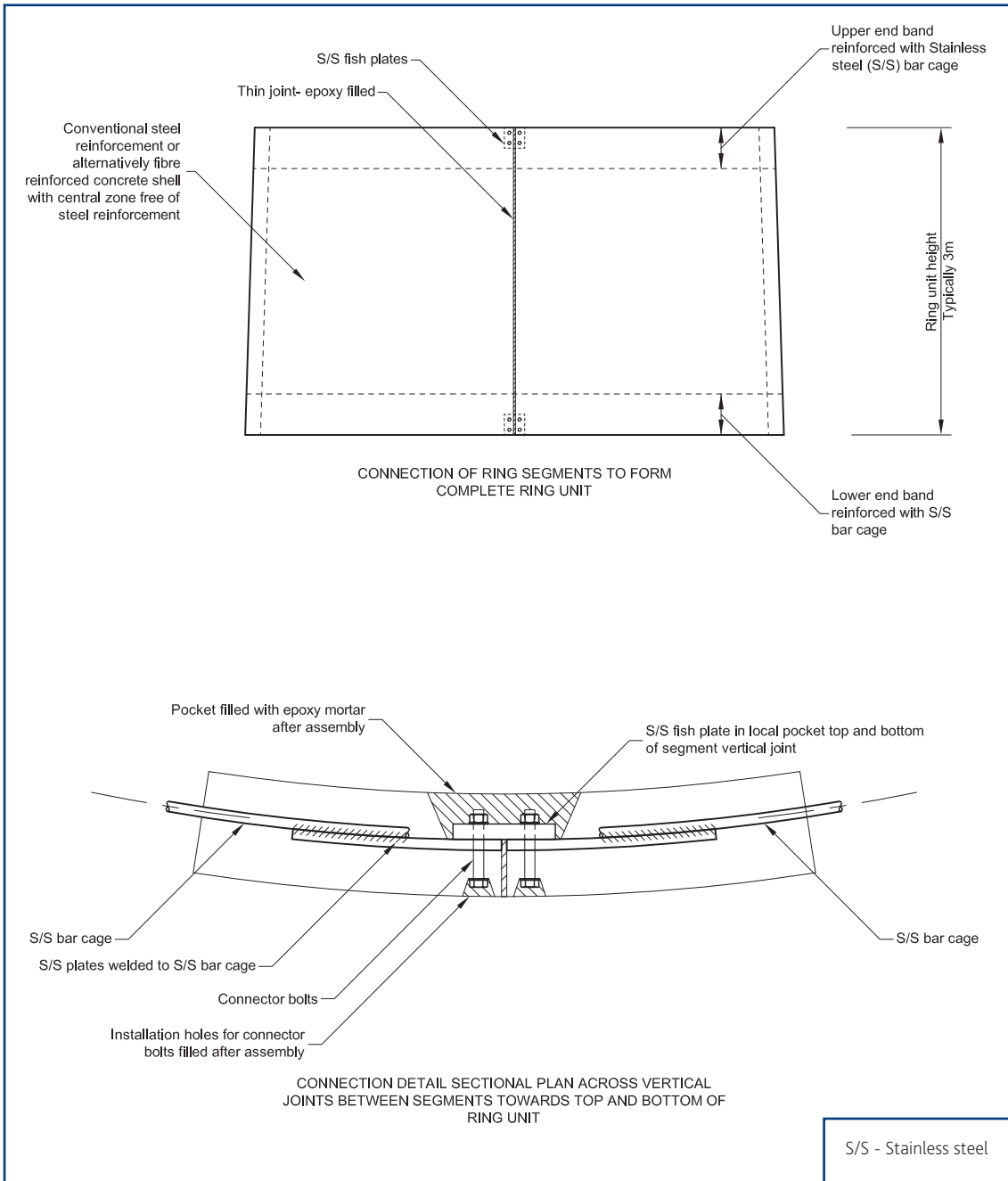

Figure 1.7  
ASSEMBLY OF RING UNITS INTO TOWER SECTIONS



**Figure 1.8**  
**TOWER SECTION JOINTS** - Anchorage section and plain joints



**Figure 1.9**  
RING UNITS - Reinforcement and segment joints

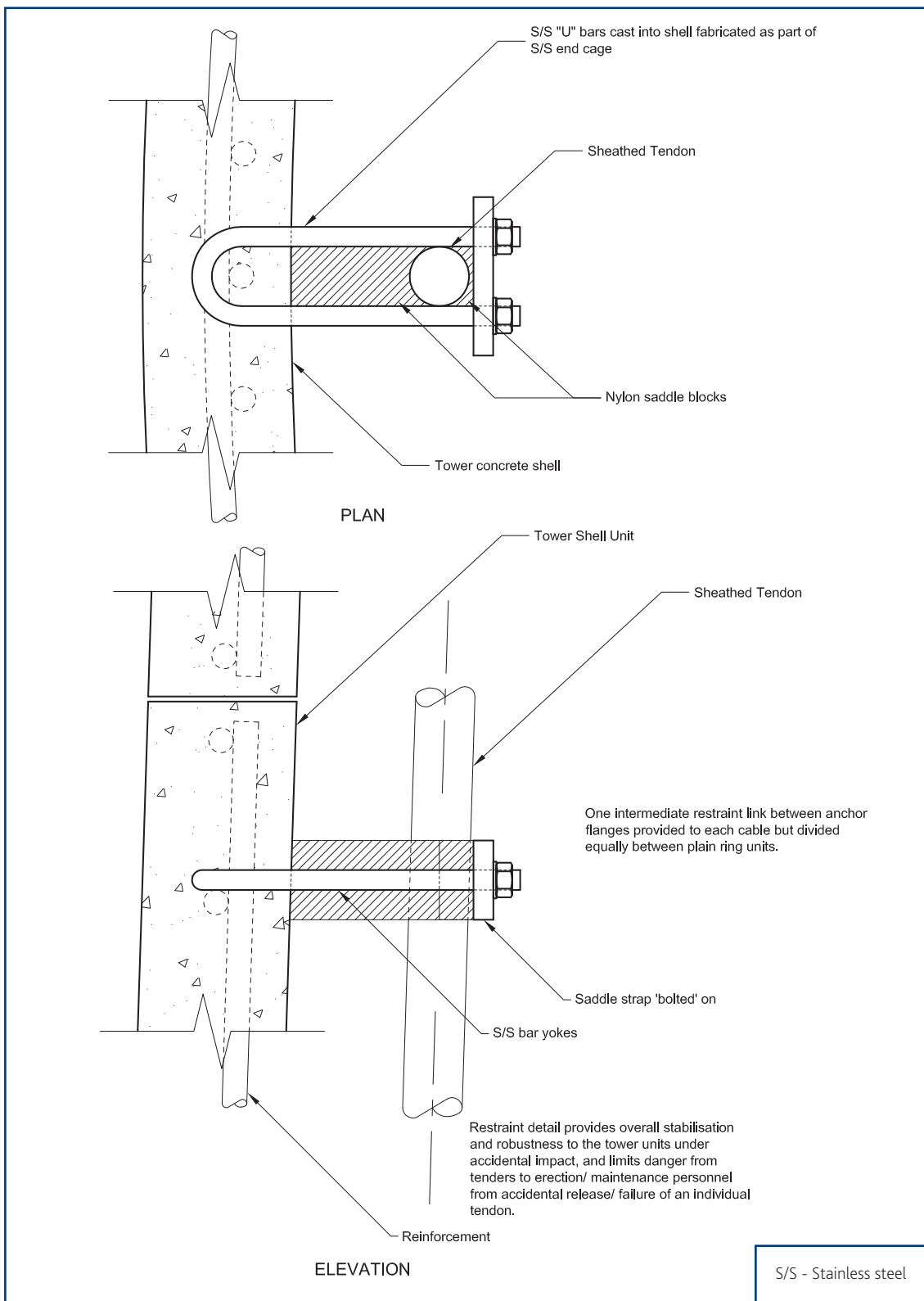

Figure 1.10  
TENDON RESTRAINTS - Yokes to plain units