

# Modeling integrated energy transportation networks for analysis of economic efficiency and network interdependencies

Esteban M. Gil, Ana M. Quelhas, James D. McCalley, Timothy Van Voorhis  
 tebagil@iastate.edu aquelhas@iastate.edu jdm@iastate.edu tvanvoor@iastate.edu

Iowa State University

**Abstract:** This paper presents a new approach for addressing the economic and physical integrity of the national electric energy system mid-term (~1 year) operation, integrating the electric, gas, coal, and water energy subsystems. The model uses the fact that each of these subsystems depends on the integrated operation of a network together with a market, and it captures the strong coupling within and between the different energy subsystems. A single integrated mathematical framework of the coal, gas, water, and electricity production and transportation systems is formulated, using a network flow optimization model with data characterizing the actual national electric energy system as it exists today in the United States, and solution algorithm anchored in the network simplex method.

**Keywords—** Energy Systems, Network Flow Optimization, Network Simplex Method

## I. INTRODUCTION

The economic and physical integrity of the electric energy system in the US depends not only on the economic and physical integrity of electric generation and transmission subsystems but also on the ability to produce and transport the various forms of raw energy that are used to generate electric energy. These raw energy forms include coal, natural gas, and water, which are responsible for 76% of the national electric energy supply with the most of the remainder being nuclear, and a small percentage being petroleum, wind, and others [1]. These three raw energy forms, together with the electric network, have the common characteristic that they are moved via a transportation system from their source of production to where they are used. Coal is mainly moved by train, barge, and truck; gas by pipelines; water by rivers and reservoir systems; and electricity by transmission lines. We refer to the system of production, transportation, conversion, and delivery as the national electric energy system (NEES), the electricity generation and supply as the electric subsystem, and the other three as coal, gas, and water subsystems, respectively. We refer to the coal, gas, and water subsystems collectively as the fuel production and delivery system (FPDS).

Although economic and physical performance of individual subsystems comprising the NEES are well studied and understood, there has been little effort to study its global characteristics. This has been partly due to the difficulty of formulating models capable of analyzing the integrated system while accounting for characteristics unique to each subsystem. More importantly, however, there has not been significant economic incentive to do so. Because regulators

perceived the electric subsystem to couple with the FPDS mainly through price and availability at the delivery site (electric generation facilities), electric utility performance has been largely judged by the differential between fuel delivery price and electricity delivery price to end-users, and as long as regulators perceived this differential to be small, most fuel costs could be easily passed on to customers. In addition, there has been little concern that contingencies in the FPDS could significantly affect electric system operation.

Today's industry climate is quite different. First, economic performance of electricity delivery is intensely scrutinized from a national perspective with electricity delivery price as a key metric. Customers and regulators are questioning electricity markets in which prices are significantly higher than those in other parts of the country, resulting in heavy pressure to identify means to lower prices. Second, the percentage of fuel purchased on the spot-market has recently increased with a corresponding decrease in the percentage of fuel purchased under long-term contracts. This increases concern on the part of generation owners that they may be more vulnerable to short- or mid-term contingencies in fuel supply. Finally, the perception has grown that the NEES, including the fuel supply system, given its role as a critical national infrastructure, may be more exposed to high-severity contingencies as result of intentional acts.

Electricity movement in the electric subsystem is occurring on a much wider scale than it has ever before, resulting in new and diverse flow patterns. This movement results from marketplace response to geographical variation in energy prices. However, decisions to buy or sell bulk electrical energy are typically made without significant consideration of using *alternative* energy transportation modes, that is, using railroads or barges for coal and pipelines for gas instead of electric transmission. Likewise, decisions to buy or sell coal or gas are typically made without significant consideration of alternative energy transportation using electric transmission. For example, coal can be moved by railroad from Wyoming to a Chicago coal-fired power plant or from Wyoming to an Omaha power plant and then by electric transmission lines to Chicago, or used at a West Virginia mine mouth plant and moved by electric transmission lines to Chicago, or moved by railroad from West Virginia to a power plant in Ohio or Indiana and then by electric transmission lines to Chicago; likewise, gas could be moved via pipeline from Louisiana to a Chicago combined cycle plant or from Louisiana to a St.

Louis power plant and then by electric transmission lines to Chicago, or brought in by pipeline direct from Canada to Chicago. Clearly, there are a large number of feasible alternatives for each of the large number of power plants (or power plant owners), and the most economic alternative varies with energy demand, production, transportation availability, and prices.

There has been significant work in fuel scheduling in order to optimize electric energy production [3-10]. We note, however, that all known approaches have seen the fuel system only in terms of contracts, i.e., there has been little effort to optimize electricity production accounting for the fuel production, storage, and transportation cost and capability.

The hydrothermal coordination problem requires solution of thermal unit commitments and dispatch simultaneous with the hydro schedules, so that energy flow via water movement has been well integrated with the solution to the electric energy production problem. Different approaches can be found in the literature to solve this problem, including Lagrangian relaxation [12-14], network linear programming [15], mixed-integer programming [16], neural networks [17], and tabu search and Bender's decomposition [18], [19].

A number of optimization models for coal transportation can also be found in the literature, with some of the earlier ones including [20], [21] and later models having additional refinements as in [22], [23]. In [24], a generalized fuzzy linear programming model for solving the coal production scheduling problem is proposed. A theory for modeling and optimizing power plant coal inventories is presented in [25].

Gas well production optimization has been addressed in several papers, such as [26] and more recently [27]. Linear and nonlinear techniques are used in [28], and in [29] the

optimization of a pipeline network in terms of the pipe diameter and routing is addressed using linear programming and dynamic programming. While the simple structure of a network formulation cannot accurately capture the non-convexities describing the feasible set of values and costs of transporting gas through the pipeline network, more general formulations are available and have proven useful in appropriate contexts [30]. The effects of non-smooth and discontinuous behaviors are addressed by [31].

A major difference between all of the above cited literature and the approach presented in this paper is that we intend to develop and study an integrated, interdependent energy system model that includes coal, gas, water, and electricity, rather than just one of them. In order to do that, a network model of the NEES is developed.

In section II the basic framework to develop a model for the NEES is presented and illustrated, while section III shows the mathematical formulation and section IV describes the highlights of the model. Section V addresses the Network LP formulation of the model. Finally, section VI summarizes the work and refers to the future research directions.

## II. NEES MODELING

### A. Fundamentals

Fig. 1 represents our view of the NEES. We take a broad view of energy systems as the electric, gas, coal, and water subsystems, noting the symmetry associated with the fact that each of these subsystems depends on the integrated operation of a network together with a market, and noting the strong coupling within and between the different energy subsystems.

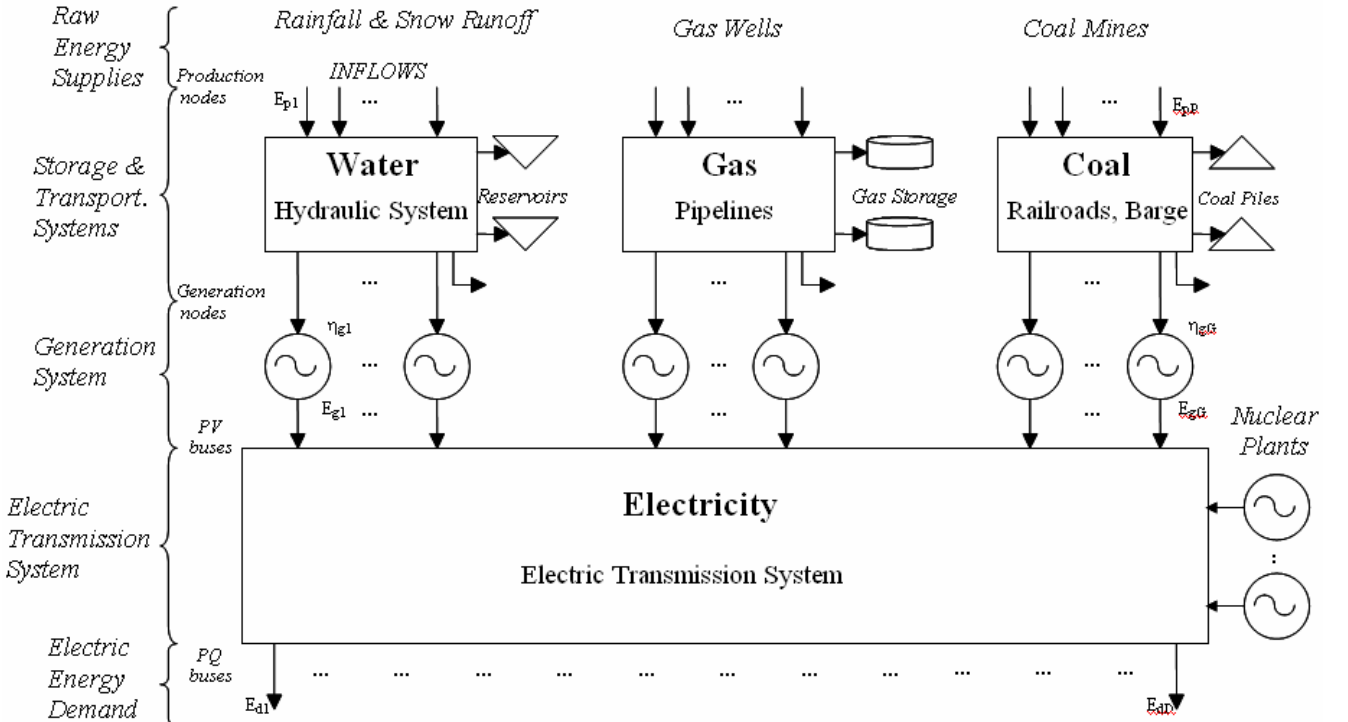

Fig. 1. The National Electric Energy System (NEES)

This coupling largely occurs through price and quantity of the energy flowing from one subsystem to another, and that it is possible to model these energy flows together in a single integrated mathematical framework of the coal, gas, water, and electricity production and transportation systems. We use a network flow optimization model, with data characterizing the actual NEES as it exists today in the United States, and solution algorithm anchored in the network simplex method.

A good initial formulation can be constructed that entirely conforms to the network flow structure. Such a structure lends itself nicely to the constraints of the problem: the capacities of the arcs in the networks provide upper bounds on the flows through those arcs. Conceptually, there is no difficulty in incorporating the time dimension (necessary to model the storage dynamics in the FPDS) by introducing arcs that connect nodes in a previous period with nodes in a future one. This also provides the means for integrating storage capacities into the formulation; these become upper bounds (or lower bounds, if needed) on arcs that connect a storage node from the prior period to the same node in the current period. However, extending an already large physical network across the time dimension greatly increases the size of the formulation and thus raises computational concerns to be addressed subsequently. Bi-directional arcs that can carry a flow in either direction (such as transmission lines) can also be incorporated.

### B. Couplings within and between energy subsystems

As seen in [32], the different energy systems are highly coupled. Intra-subsystem coupling exists between four basic functionalities: supply, transportation (the networks), storage (except for electricity), and demand. For example, the demand of gas influences its supply and transport, an obvious intra-system coupling that is apparent for electricity and coal as well. The supply for water, on the other hand, is independent of its demand, but rather determined by rainfall and snow runoff.

There also exists inter-subsystem coupling, corresponding to dependencies between the electric, coal, gas, and water subsystems. The subsystems interaction occurs mainly through the electricity subsystem. For example, the supply of electricity largely determines the demand for coal and gas. Likewise, limitations to coal or gas demand have a direct bearing on electricity supply. Electricity supply also affects, and is affected by, water storage in reservoirs and the associated scheduling of reservoir-hydroelectric units. Run-of-the-river hydroelectric units, on the other hand, are normally not scheduled per se but rather run to capacity; as such, they are considered as directly decreasing the electricity demand. Although most rivers used for hydroelectric generation are not used for coal transport, there are some exceptions, and thus there may be some coupling between river and coal transport. One unique inter-subsystem coupling occurs between gas and electricity demand. The reason for this is that many customers have capability to use either gas or electric heat.

All energy systems are vulnerable to disruptions. Occurrence of these disruptions causes undesirable effects to propagate through the energy system, usually resulting in pronounced observability of the various intra- and inter-subsystem couplings that we have described. Usually, this observability occurs through price and availability of an energy source or price and availability of its transportation function.

### C. Definitions

Some basic definitions are required in order to effectively formulate a network model of the NEES.

- **Node:** A fuel production facility (coal mine or gas well), a coal, gas, or water storage facility, an electric generation plant, an electric load center, or a group of facilities having similar characteristics.
- **Arc or link:** a transportation route and associated transportation mode between production, storage, or generation. The expression transportation route refers to the physical path between two points, while transportation mode denotes the method used. Transportation modes include railroad, barge, pipeline, truck, and multimodal for coal, pipeline for gas, and electric transmission lines for electricity. In addition, capacitation of nodes (e.g., maximum power plant generation) is done through connecting the node through a fictitious arc having capacity equal to the nodal limit. The term “arc” is motivated by the language of the mathematical programming methods. We also use the term “link” synonymously.
- **Path:** a set of arcs from a coal or gas production facility to an electrical load center.
- **Flow:** An amount of energy moving along an arc or path during a given time interval.
- **Flow pattern:** The set of flows during a given time interval moving through the NEES or a particular region of the NEES.

### D. Model assumptions

1. **Analysis time frame:** We confine our analysis to a mid-term operational interval of 1 year.
2. **Energy flow:** All energy flows (or “energy packets”) are converted from their standard units into units of 100 MW-weeks using appropriate conversion factors for coal short-tons and gas cubic feet.
3. **Capacities:** Arc capacitation is used to model production and transportation capacities for all subsystems, and storage capacities for water, coal, and gas, in units of 100 MW-weeks.
4. **Passage time uniformity:** The passage time, i.e. the energy delivery time from raw fuel production to electric consumption, is uniform, independent of the fuel type, the transportation mode, the transportation distance, and the generation facility.
5. **Passage time interval:** The passage time is 1 week; thus, solution time intervals will be 1 week.
6. **Losses:** We model no energy losses in coal, gas, or water production or transportation, but we will account for

losses in the energy conversion process at generation facilities and in electric transmission.

7. *Laws of physics*: We assume each subsystem network can be represented by an energy flow system where interdependencies between flows occur only through conservation of energy flow at each node. Therefore, a feasible flow pattern requires only nodal flow conservation (together with link capacity satisfaction). For the electric network, this assumption implies that Kirchoff's laws are not enforced. Such an assumption is unacceptable when performing traditional electric network analysis of power flows associated with a particular network configuration, loading condition, generation dispatch, and voltage profile, in which case, a power flow program is essential. This assumption may be acceptable for analysis of bulk energy transport, where we desire to identify weekly aggregate energy movements rather than instantaneous snapshots of power flows.
8. *Environmental effects*: Environmental effects including those from surface mining, hydroelectric scheduling (e.g., fish kills), and power plant emissions, do not affect bulk energy flows.
9. *Level of production represented*: Small production facilities will not be modeled.
10. *Transportation levels represented*: Lower level transportation links will not be modeled.
11. *Electricity demand*: Electricity demand will be modeled according to forecasts based on historical demand data.
12. *Linear costs*: Coal, gas, and electric energy production and transportation costs are assumed to increase linearly with the appropriate quantities.
13. *Energy contracts*: The major energy contracts will be modeled by constraining the flows and adjusting the respective per unit costs in the implicated arcs.

### E. Network formulation example

Fig.2 illustrates the network formulation considering three time steps in a small energy system with 2 production facilities (nodes 1, 1', 2, and 2'), a storage facility for one of them (node 3), two generators (nodes 4, 4', 5, and 5'), and one demand node (node 6).  $E_{33,0}$  and  $E_{33,3}$  are the energy at the beginning and end of the scheduling period in the storage facility.  $E_{61}$ ,  $E_{62}$ , and  $E_{63}$  are the forecasted energy demands for each time step in the demand node.

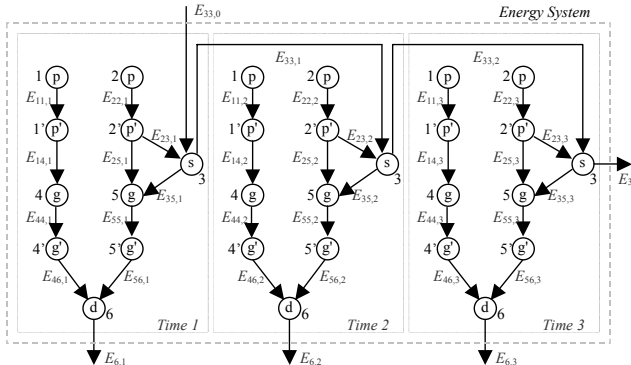

Fig. 2. Network formulation illustrative example

### F. Data

In order to implement an actual model of the NEES, obtaining appropriate data for the largest capacity production, storage, demand, and transportation components is essential. Nodal (production, storage, and demand) data minimally requires geographic location, capacity, efficiency, and per-unit cost. Branch (transportation/transmission routes and modes) data minimally requires termination points, capacities, efficiencies, and per-unit costs. Obtaining such a large mass of data is challenging, but we have excellent contacts with appropriate industry contacts including the North American Electric Reliability Council (NERC), its regional offices, many gas and electric utilities and independent system operators (ISOs). In addition, the Department of Energy maintains some helpful databases that we have access to through contacts at the Energy Information Administration (EIA). Finally, a large amount of data is available for purchase through Platts.

### III. MATHEMATICAL FORMULATION

Under the assumptions stated in section II-D, we model the entire problem as a single network with capacitated arcs, an upper-bounded (or capacitated) transshipment problem, also known as a minimum cost-flow problem, according to:

$$Z = \min\{\underline{C} \cdot \underline{E}\} \quad (1)$$

subject to:

$$\underline{A} \cdot \underline{E} = \underline{b}, \quad (2)$$

$$\underline{E}_{\min} \leq \underline{E} \leq \underline{E}_{\max} \quad (3)$$

where the energy production and transportation problem for coal, water, and gas subsystems are solved simultaneously with the electricity production and transportation problem in an overall optimization schema. The per-unit cost vector  $\underline{C}$  includes the costs associated with each arc. The energy flows vector  $\underline{E}$  includes all the decision variables. Each column of the incidence matrix  $\underline{A}$  has an associated decision variable, and each row has an associated energy balance equation. There is one balance equation per node (with exception of production nodes). The only elements of  $\underline{A}$  not equal to 1 are those representing electric generation and transmission where we utilize gain factors to account for losses.

	Time step 1										Time step 2										Time step 3										
	$E_{11,1}$	$E_{22,1}$	$E_{33,1}$	$E_{44,1}$	$E_{55,1}$	$E_{61,1}$	$E_{62,1}$	$E_{63,1}$	$E_{11,2}$	$E_{22,2}$	$E_{33,2}$	$E_{44,2}$	$E_{55,2}$	$E_{61,2}$	$E_{62,2}$	$E_{63,2}$	$E_{11,3}$	$E_{22,3}$	$E_{33,3}$	$E_{44,3}$	$E_{55,3}$	$E_{61,3}$	$E_{62,3}$	$E_{63,3}$							
1'	1	0	-1	0	0	0	0	0	0	0	0	0	0	0	0	0	0	0	0	0	0	0	0	0	0	$E_{33,0}$					
2'	0	1	0	-1	-1	0	0	0	0	0	0	0	0	0	0	0	0	0	0	0	0	0	0	0	0	$E_{33,1}$					
3	0	0	0	-1	1	0	-1	0	0	0	0	0	0	0	0	0	0	0	0	0	0	0	0	0	0	$E_{33,2}$					
4	0	0	0	0	0	0	0	0	0	0	0	0	0	0	0	0	0	0	0	0	0	0	0	0	0	$E_{33,3}$					
4'	0	0	0	0	0	0	0	0	0	0	0	0	0	0	0	0	0	0	0	0	0	0	0	0	0	$E_{61,1}$					
5	0	0	0	0	0	0	0	0	0	0	0	0	0	0	0	0	0	0	0	0	0	0	0	0	0	$E_{61,2}$					
5'	0	0	0	0	0	0	0	0	0	0	0	0	0	0	0	0	0	0	0	0	0	0	0	0	0	$E_{61,3}$					
6	0	0	0	0	0	0	0	0	0	0	0	0	0	0	0	0	0	0	0	0	0	0	0	0	0	$E_{62,1}$					
6	0	0	0	0	0	0	0	0	0	0	0	0	0	0	0	0	0	0	0	0	0	0	0	0	0	$E_{62,2}$					
6	0	0	0	0	0	0	0	0	0	0	0	0	0	0	0	0	0	0	0	0	0	0	0	0	0	$E_{62,3}$					
6	0	0	0	0	0	0	0	0	0	0	0	0	0	0	0	0	0	0	0	0	0	0	0	0	0	$E_{63,1}$					
6	0	0	0	0	0	0	0	0	0	0	0	0	0	0	0	0	0	0	0	0	0	0	0	0	0	$E_{63,2}$					
6	0	0	0	0	0	0	0	0	0	0	0	0	0	0	0	0	0	0	0	0	0	0	0	0	0	$E_{63,3}$					
																										$E_{63,3}$					

Fig. 3. Incidence matrix for the example

The equation  $A \cdot E = b$  for the small example stated in section II-E is set out in Fig. 3 in order to illustrate the block diagonal structure of the incidence matrix. Note that every column of  $A$  has no more than two non-zero elements, which allows us to use the network LP solution approach.

A more detailed mathematical model is provided below (nomenclature is provided in the Appendix).

Objective function:

$$\begin{aligned} \min Z = & \underbrace{\sum_{\forall t} \sum_{\forall p} c_p \cdot E_{ppt}}_{\text{Total production cost}} + \underbrace{\sum_{\forall t} \sum_{\forall g} g_g \cdot E_{ggt}}_{\text{Total generation cost}} + \underbrace{\sum_{\forall t} \sum_{\forall s} s_s \cdot E_{sst}}_{\text{Total storage cost}} + \\ & \underbrace{\sum_{\forall t} \sum_{\forall p} \sum_{\forall g} \sum_{\forall m} t_{pgmt} \cdot E_{pgmt} + \sum_{\forall t} \sum_{\forall p} \sum_{\forall s} \sum_{\forall m} t_{psmt} \cdot E_{psmt} + \sum_{\forall t} \sum_{\forall s} \sum_{\forall g} \sum_{\forall m} t_{sgmt} \cdot E_{sgmt}}_{\text{Total transportation cost for the gas and coal subsystems}} + \\ & \underbrace{\sum_{\forall t} \sum_{\forall r} t_{rt} \cdot E_{rt}}_{\text{Total electric transmission cost}} \end{aligned}$$

subject to:

1) Energy balance at the production nodes:

$$E_{ppt} - \sum_{\forall g} \sum_{\forall m} E_{pgmt} - \sum_{\forall s} \sum_{\forall m} E_{psmt} = 0, \quad \forall p \quad \forall t \quad (5)$$

2) Energy balance at the storage nodes:

$$-E_{sst} + E_{ss,t-1} + \sum_{\forall p} \sum_{\forall m} E_{psmt} - \sum_{\forall g} \sum_{\forall m} E_{sgmt} = 0, \quad \forall s \quad \forall t \quad (6)$$

3) Energy balance at the generation nodes:

$$\sum_{\forall s} \sum_{\forall m} E_{sgmt} + \sum_{\forall p} \sum_{\forall m} E_{pgmt} - E_{ggt} = 0, \quad \forall g \quad \forall t \quad (7)$$

4) Energy balance at the electric transmission nodes (buses of the actual transmission system):

For all the electric transmission nodes  $d$  and for every time  $t$ , the total flow coming into the node must equal the total flow leaving the node. The flow going into the node comes from generation nodes and/or other nodes in the electric transmission system, and is adjusted according to the efficiencies of the incident arcs, respectively  $\eta_g$  and  $\eta_r$  (to account for losses). The flow leaving the node goes to other nodes in the electric transmission system and/or to the forecasted demand for that node ( $E_{dt}$ ). A general formulation of this constraint for each node  $j$  is as follows:

$$\sum_{\forall i} \eta_{ij} \cdot E_{ij} - \sum_{\forall k} E_{jk} = E_{j,output} - E_{j,input} \quad (8)$$

where  $E_{ij}$  is energy from node  $i$  to node  $j$ ,  $E_{jk}$  is energy from node  $j$  to node  $k$ ,  $E_{j,input}$  is energy from outside the system to node  $j$  (e.g., initial storage levels, as presented in the example below), and  $E_{j,output}$  is energy from node  $j$  to outside the system (e.g., electric demand).

5) Minimum and maximum limits of the decision variables:

These limits are due to the production, storage, generation, and transportation capacities.

#### IV. MODEL HIGHLIGHTS

**Energy balance equations:** All energy balance equations can be expressed using an equation similar in structure to (8), independent of the type of node considered.

**Electric transmission topology:** Although Kirchoff's laws are not enforced (per the assumptions), the model does in fact accurately represent the topology of the electric network. Capturing network topology for the electric system is more difficult than that of gas and coal because of the fact that electric links are necessarily bi-directional (gas and coal transportation arcs, although having capability of flow in either direction, usually transport energy in only one direction). Although capacitated transshipment problems generally require that each arc be directed, we may represent bi-directed arcs using 2 separate, oppositely directed arcs between each pair of nodes. This is satisfactory since network simplex solutions at the optimal prevent "cycled flows" where both paralleled, oppositely directed arcs have non-zero flows; thus, at the optimal, one arc of every pair of paralleled, oppositely directed arcs will have zero flow, as it should.

**Electric subsystem losses:** Losses occurring in electric generation and transmission are modeled using appropriately chosen gain factors on the arcs.

**Production capacity limits:** We use 2 nodes ( $p$  and  $p'$ ) to represent each production facility (coal mines, gas wells) or group of production facilities. Energy imports are represented as production nodes. There is one energy balance equation associated with each  $p'$  node for each time  $t$ .

**Generation capacity limits:** We use 2 nodes ( $g$  and  $g'$ ) to represent each generation facility or group of generation facilities. There are 2 energy balance equations for each generator: one for  $g$  and one for  $g'$ , for each time  $t$ . The arc between them represents the energy conversion process.

**Hydro scheduling problem:** The hydro scheduling optimization problem (as presented in [11], [15], and [33]) can be easily incorporated in the network LP mathematical formulation proposed. In order to do that, appropriate gains must be assigned to the arcs connecting the different nodes of the water subsystem.

**Decomposability:** This mathematical formulation provides for simultaneous solution of simplified versions of the energy production, transportation, and storage problems for the NEES as a whole, considering a specified scheduling horizon. Since it allows modularity and decomposition at different levels, we can disaggregate the problem by energy type, time frame, geographical area, etc, in order to perform a variety of analyses. Furthermore, under the important assumption of linear costs, the optimization problem can be solved by network linear programming, as it will be addressed in section V.

#### V. NETWORK LINEAR PROGRAMMING

It is well known that problems involving linear objectives and linear constraints, linear programs (LP), can be solved by the very efficient simplex algorithm. If, however, the

constraints can be formulated such that every column of the node-branch incidence matrix has at most two non-zero entries, then the problem has a network structure and is called a network LP, and computational efficiency can be further improved by 2 orders of magnitude [34] using the network simplex method. This is very important for our work as we envision, ultimately, the potential of solving a network having a number of arcs (each arc at each time period, with 52 weekly time periods, represents a decision variable) in the range of several million.

There are considerable computational advantages to problems having network structure as the efficiency of the network simplex method enables it to solve far larger LPs than the regular simplex method could in a reasonable amount of time. The CPLEX software, for example, has a first-rate implementation of the network simplex algorithm [35]. Nevertheless, in order to solve such a large LP and to refine this relatively simple model when needed, customized algorithms that exploit the structure of the network need also to be developed.

Efficient techniques for solving the initial LP can take advantage of the natural topology of the network. A large number of arcs connect various nodes within a single period, but relatively few arcs connect periods (mainly those associated with storage and, later, transportation delays). This implies that most of the constraint coefficient matrix is block-angular with complicating constraints that couple the solutions for different periods, as seen in Fig. 3. This type of structure lends itself nicely to decomposition techniques, particularly the price-directive schemes Lagrangian relaxation and Dantzig-Wolfe decomposition. Decomposition has proven particularly effective for certain types of network problems (prominently multi-commodity flows [34]), so there is reason to believe that it could also be successfully applied in this context. Just as the problem is largely separable by time period, it also is somewhat separable by subsystem. While electric generation connects each subsystem into an integrated network, the coal transportation and gas pipeline networks, for example, do not share any arcs. Even various hydro networks, which operate on separate river systems, are essentially independent. Thus, there are multiple opportunities for decomposing the problem into smaller pieces.

Finally, Benders' decomposition (a resource-directive approach) could be especially useful since it decomposes the problem by variables rather than constraints. For example, if the desire is to refine the model of electricity generation, the variables associated with electricity generation would be the complicating variables. In this scheme, the master problem would minimize total cost over these variables, while sub-problems would optimally supply the resources needed to generate electricity, as specified by the complicating variables. An analogous strategy could be developed to refine other parts of the model, albeit with different choices of complicating variables.

Excellent references on network modeling and solution

algorithms include [36]-[41].

## VI. CONCLUSIONS

This paper addresses the U.S. electric energy system from a new perspective integrating the electric, coal, gas, and water subsystems in a single model that conforms to a network flow structure, in order to study the economic and physical integrity of the NEES as a whole.

The notion of studying the flow of *energy* through the respective networks, rather than the movement of coal tonnage, gas or water volume, or electric power, elicits a thought-provoking view that may reveal new perspectives in relation to NEES analysis, operation, and planning.

An important impact of the work will be to motivate generation owners and fuel suppliers to utilize the identified flow patterns by overcoming informational, organizational, and/or political barriers, by increasing link or production capacity, or by building new links or production facilities. In addition, our work will serve well in guiding the most effective use of resources in strengthening NEES infrastructure for economic benefits and for enhancing its resilience to contingencies caused by intentional acts or natural causes. Finally, we expect that our work to provide useful information regarding tradeoffs between environmental impacts (e.g., power plant emissions, fish kills, surface mining) and energy economics.

## APPENDIX: NOMENCLATURE

### Objective Function

$Z$ : total cost (production, storage, and transportation) of the energy over 1 year at weekly intervals

### Indexes:

$p$ : production node  $g$ : generation node

$d$ : electric transmission node  $s$ : storage node

$m$ : transportation mode  $r$ : transmission line

### Per unit costs:

$c_p, g_g, s_s$ : per unit cost of extraction, generation (without including the fuel cost to avoid duplications), and storage, respectively

$t_{pgmt}, t_{psmt}, t_{sgmt}$ : per unit cost of gas or coal transportation from a production or storage node (first index) to a storage or generation node (second index), using the transportation mode  $m$ , at time  $t$

$t_{rt}$ : per unit cost of the electric energy transported by the transmission line  $r$ , at time  $t$

### Decision variables (energy flows):

$E_{ppi}$ : total energy produced in the production node  $p$  during time  $t$

$E_{ssi}$ : energy at the storage facility  $s$  at the end of time  $t$

$E_{ggi}$ : total energy arriving to the generation facility  $g$  at time  $t$

$E_{pgmt}, E_{psmt}, E_{sgmt}$ : amount of energy going from a production or storage node (first index) to a storage or generation node (second index), shipped using the transportation mode  $m$  during the time  $t$

$E_{rt}$ : amount of electric energy flow in the transmission line  $r$  during the time  $t$

**Input data:**

$E_{dt}$ : forecasted energy demand in the electric node  $d$  during the time  $t$

$E_{ss,0}$ ,  $E_{ss,T}$ : energy in the storage facility  $s$  at the beginning and end of the scheduling horizon, respectively

$\eta_g$ : efficiency of the energy conversion process at the generation node  $g$

$\eta_r$ : efficiency of the energy transmission line  $r$

## VII. REFERENCES

- [1] U.S. Department of Energy, Energy Information Administration, "U.S. electric power industry summary statistics", September 2002. [Online]. Available: <http://www.eia.doe.gov/fuelelectric.html>.
- [2] U.S. Department of Energy, Energy Information Administration, "Annual energy review 2001", [Online]. Available: <http://www.eia.doe.gov/emeu/aer/elect.html>.
- [3] A. Wood and B. Wollenberg, "Power Generation, Operation, and Control", John Wiley & Sons Inc., 1996.
- [4] S. Vermuru and L. Lemonidis, "Fuel scheduling", a paper in the IEEE Power Engineering Society tutorial special publication 90EH0238-5-PWR, "Application of optimization methods for economy/security functions in power system operations", IEEE Power Engineering Society, 1990.
- [5] V. Vickers, W. Hobbs, S. Vemuri, and D. Todd, "Fuel resource scheduling with emission constraints", IEEE Transactions on Power Systems, Vol. 9, pp 1531-1538, 1994.
- [6] M. Djukanovic, B. Babic, and B. Milosevic, "Fuzzy linear programming based optimal fuel scheduling incorporating blending/transloading facilities", IEEE Transactions on Power Systems, Vol. 11, pp 1017-1023, 1996.
- [7] J.S. Shih and H.C. Frey, "Coal blending optimization under uncertainty", Proceedings of the Tenth Annual International Pittsburgh Coal Conference, pp 1110-1115, September, 1993.
- [8] L.D. Rosenberg, D.A. Williams, and J.D. Campbell, "Fuel scheduling and accounting", IEEE Transactions on Power Systems, Vol.5, pp 682-688, 1990.
- [9] K. Moslehi, V.R. Sherkat, and F. Cacho Ruiz, "Optimal scheduling of long-term fuel purchase, distribution, storage and consumption", Proceedings of the Power Industry Computer Application Conference, pp 98-104, 1991.
- [10] K.P. Wong and Y.W. Wong, "Hybrid genetic/simulated annealing approach to short-term multiple-fuel-constrained generation scheduling", IEEE Transactions on Power Systems, Vol. 12, pp 776-784, 1997.
- [11] M. El-Hawary, "Hydro-thermal scheduling of electrical power systems", a paper in the IEEE Power Engineering Society tutorial special publication 90EH0238-5-PWR, "Application of optimization methods for economy/security functions in power system operations", IEEE Power Engineering Society, 1990.
- [12] R.B. Johnson, A.J. Svoboda, and C. Greif, "Positioning for a competitive electric industry with PG and E's hydro-thermal optimization model", Interfaces, Vol. 29, pp 53-74, 1998.
- [13] S. Al-Agtash, and R. Su, "Augmented Lagrangian approach to hydro-thermal scheduling", IEEE Transactions on Power Systems, Vol. 13, pp 1392-1400, 1998.
- [14] S. Ruzic, and N. Rajakovic, "Optimal distance method for Lagrangian multipliers updating in short-term hydro-thermal coordination", IEEE Transactions on Power Systems, Vol. 13, pp 1439-1444, 1998.
- [15] A. Johannesen, A. Gjelsvik, O.B. Fosso, and N. Flatabo, "Optimal short term hydro scheduling including security constraints", IEEE Transactions on Power Systems, Vol. 6, pp 576-583, 1991.
- [16] N. Tufegdzic, R.J. Frowd, and W.O. Stadlin, "A coordinated approach for real-time short term hydro scheduling", IEEE Transactions on Power Systems, Vol. 11, pp 1698-1704, 1996.
- [17] R.H. Liang, and Y.Y. Hsu, "Short-term hydro-scheduling using Hopfield neural network", IEE Proceedings Generation, Transmission and Distribution, Vol. 143, pp 269-275, 1996.
- [18] X. Bai, and S.M. Shahidehpour, "Hydro-thermal scheduling by tabu search and decomposition method", IEEE Transactions on Power Systems, Vol. 11, pp 968-974, 1996.
- [19] M.V. Pereira and L.M.V.G. Pinto, "Application of decomposition techniques to the mid- and short-term scheduling of hydrothermal systems", IEEE Transactions on Power Apparatus and Systems, Vol. PAS-102, No 11, pp 3611-3618, November, 1983.
- [20] E. Morlok and R. Peterson, "Railroad freight train scheduling: a mathematical programming formulation", A research report from the Transportation Center and the Technological Institute of Northwestern University, Evanston, Ill, May, 1970.
- [21] R. Bernknopf, "Domestic coal distribution: an interregional programming model for the U.S. coal industry", JAI Press Inc., Greenwich, Connecticut, 1985.
- [22] G. Elmes, "Coal transportation: an undervalued aspect of energy modeling?", Transportation Research Part A, Vol. 18A, pp 13-23, 1984.
- [23] C.J. Chang, R.D. Miles, and K.C. Sinha, "A regional railroad network optimization model for coal transportation", Transportation Research Part B, Vol. 15B, pp 227-238, 1981.
- [24] P.C. Pendharkar, "A fuzzy linear programming model for production planning in coal mines", Computers & Operations Research, Vol. 24, No. 12, pp 1141-1149, 1997.
- [25] H.M. Merrill, "Optimizing plant and system coal inventories", IEEE Transactions on Power Systems, pp 337-342, 1988.
- [26] A.B. Bitsindou, M.G. Kelkar, "Gas well production optimization using dynamic nodal analysis", Proceedings of the Mid-Continental Operations Symposium of the Society of Petroleum Engineers, 1999.
- [27] J.J. Edwards, "Gas well production optimization with remote performance monitoring", Proceedings of the Petroleum Society's Canadian International Petroleum Conference, 2002.
- [28] P. Linden, M. Goodreau, U. Basu, G. Venkataramanan, and P. Fereber, "Gas pipeline optimization", Proceedings of the Annual Pipeline Simulation Interest Group Conference, 1999.
- [29] S. Siregar, S.M. Nababn, R. Saragih, N. Nuraini, B. Arif, and D. Chaerani, "The importance of gas pipeline network optimization", Proceedings of the Sixth AESEAP Triennial Conference, August, 2000.
- [30] C. Swoveland and J. Lydiatt, "Gas takes new approach to supply optimization" Pipeline and Gas Journal, Vol. 220, pp 20-30, 1993.
- [31] R.G. Carter, D.W. Schroeder, and T.D. Harbick, "Some causes and effect of discontinuities in modeling and optimizing gas transmission networks", Proceedings of the Annual Pipeline Simulation Interest Group Conference, 1993.
- [32] A. Quelhas, J.D. McCalley, "Modeling Energy system Information Flows", 34<sup>th</sup> North American Power Symposium (NAPS), October 2002
- [33] G.S. Christensen and S.A. Soliman, "Optimal Long-Term Operation of Electric Power Systems", Plenum Press, 1988.
- [34] M.S. Bazaraa, J.J. Jarvis, and H.D. Sherali, "Linear Programming and Network Flows" John Wiley & Sons, New York, 1990.
- [35] CPLEX Division, ILOG Inc., CPLEX optimization package, USA, 1998. [Online]. Available: [www.cplex.com](http://www.cplex.com)
- [36] F. Glover, D. Klingman, and N. Phillips, "Network models in optimization and their applications in practice," Wiley, 1992.
- [37] V. Chvatal, "Linear Programming", W. Freeman and Company, New York, 1980.
- [38] V. Balakrishnan, "Network optimization", Chapman & Hall, New York, 1995.
- [39] R. Potts and R. Oliver, "Flows in transportation networks", Academic Press, New York, 1972.
- [40] H. Eiselt and C. Sandblom, "Integer programming and network models", Springer, New York, 2000.
- [41] Robert E. Bixby, "Solving real-world linear programs: a decade and more of progress", Operations Research 50, n. 1, pp 3-15, 2002.

## VIII. BIOGRAPHIES

**Esteban M. Gil** was born in Santiago, Chile. He obtained his B.Sc. and M.Sc. degrees in Electrical Engineering from Universidad Técnica Federico Santa María (UTFSM), Valparaíso, Chile, in 1997 and 2001 respectively. His research interests focus mainly on economics, optimization, operation and planning of electric power systems. He is currently working towards a PhD degree at Iowa State University. He is a student member of IEEE.

**Ana M. Quelhas** was born in Porto, Portugal. She graduated from the Faculdade de Engenharia, Universidade do Porto, Portugal, in Electrical and

Computer Engineering (1999). She obtained her M.S. degree in Electrical Engineering from Iowa State University (2001). Currently she is working towards her Ph.D. degree, also in Electrical Engineering, at Iowa State University. She is a student member of IEEE.

**James D. McCalley** is an associated Professor of Electrical and Computer Engineering Department at Iowa State University, where he was employed since 1992. He worked for Pacific Gas and Electrical Company from 1986 to 1990. Dr. McCalley received the B.S. (1982), M.S. (1986), and Ph.D. (1992) degrees in Electrical Engineering from Georgia Tech. He is a registered professional engineer in California and a senior member of the IEEE.

**Timothy Van Voorhis** received his Ph.D. in optimization at Georgia Tech in 1997. After graduation, he joined the Industrial Engineering Department at Iowa State University, where he worked until recently accepting a position in mathematics at Liberty University. His research interests include sports scheduling, global optimization, steel foundry scheduling and optimization applications in power systems.