

The IEEE Reliability Test System - 1996 *

A report prepared by the Reliability Test System Task Force * of the Application of Probability Methods Subcommittee

ABSTRACT

This report describes an enhanced test system (RTS-96) for use in bulk power system reliability evaluation studies. The value of the test system is that it will permit comparative and benchmark studies to be performed on new and existing reliability evaluation techniques. The test system was developed by modifying and updating the original IEEE RTS (referred to as RTS-79 hereafter) to reflect changes in evaluation methodologies and to overcome perceived deficiencies.

INTRODUCTION

The first version of the IEEE Reliability Test System (RTS-79) was developed and published in 1979 [1] by the Application of Probability Methods (APM) Subcommittee of the Power System Engineering Committee. It was developed to satisfy the need for a standardized data base to test and compare results from different power system reliability evaluation methodologies. As such, RTS-79 was designed to be a reference system that contains the core data and system parameters necessary for composite reliability evaluation methods. It was recognized at that time that enhancements to RTS-79 may be required for particular applications. However, it was felt that additional data needs could be supplemented by individual authors and/or addressed in future extensions to the RTS-79.

In 1986 a second version of the RTS was developed (RTS-86) and published [2] with the objective of making the RTS more useful in assessing different reliability modeling and evaluation methodologies. Experience with RTS-79 helped to identify the critical additional data requirements and the need to include the reliability indices of the test system. RTS-86 expanded the data system primarily relating to the generation system. The revision not only extended the number of generating units in the RTS-79 data base but also included unit derated states, unit scheduled maintenance, load forecast uncertainty and the effect of interconnection. The advantage of RTS-86 lies in the fact that it presented the system reliability indices derived through the use of rigorous solution techniques without any approximations in the evaluation process. These exact indices serve to compare with results obtained from other methods.

Since the publication of RTS-79, several authors have reported the results of their research in the IEEE Journals and many international journals using this system. Several changes in the electric utility industry have taken place since the publication of RTS-79, e.g. transmission access, emission caps, etc. These changes along with certain perceived enhancements to RTS-79 motivated this task force to suggest a multi-area RTS incorporating additional data.

* Co-Chairmen: C. Grigg and P. Wong; P. Albrecht, R. Allan, M. Bhavaraju, R. Billinton, Q. Chen, C. Fong, S. Haddad, S. Kuruganty, W. Li, R. Mukerji, D. Patton, N. Rau, D. Reppen, A. Schneider, M. Shahidehpour, C. Singh. See Biographies for affiliations.

96 WM 326-9 PWRs A paper recommended and approved by the IEEE Power System Engineering Committee of the IEEE Power Engineering Society for presentation at the 1996 IEEE/PES Winter Meeting, January 21-25, 1996, Baltimore, MD. Manuscript submitted August 1, 1995; made available for printing January 15, 1996.

It should be noted that in developing and adopting the various parameters for RTS-96, there was no intention to develop a test system which was representative of any specific or typical power system. Forcing such a requirement on RTS-96 would result in a system with less universal characteristics and therefore would be less useful as a reference for testing the impact of different evaluation techniques on diverse applications and technologies. One of the important requirements of a good test system is that it should represent, as much as possible, all the different technologies and configurations that could be encountered on any system. RTS-96 therefore has to be a hybrid and atypical system.

SYSTEM TOPOLOGY

The topology for RTS-79 is shown in Figure 1 and is labeled "Area A." Since the demand for methodologies that can analyze multi-area power systems has been increasing lately due to increases in interregional transactions and advances in available computing power, the task force decided to develop a multi-area reliability test system by linking various single RTS-79 areas. Figure 2 shows a two-area system developed by merging two single areas - "Area A" and "Area B" through three interconnections. As shown the two areas are interconnected by the following new interconnections:

- 51 mile 230 kV line connecting bus # 123 and bus # 217
- 52 mile 230 kV line connecting bus # 113 and bus # 215
- 42 mile 138 kV line connecting bus # 107 and bus # 203.

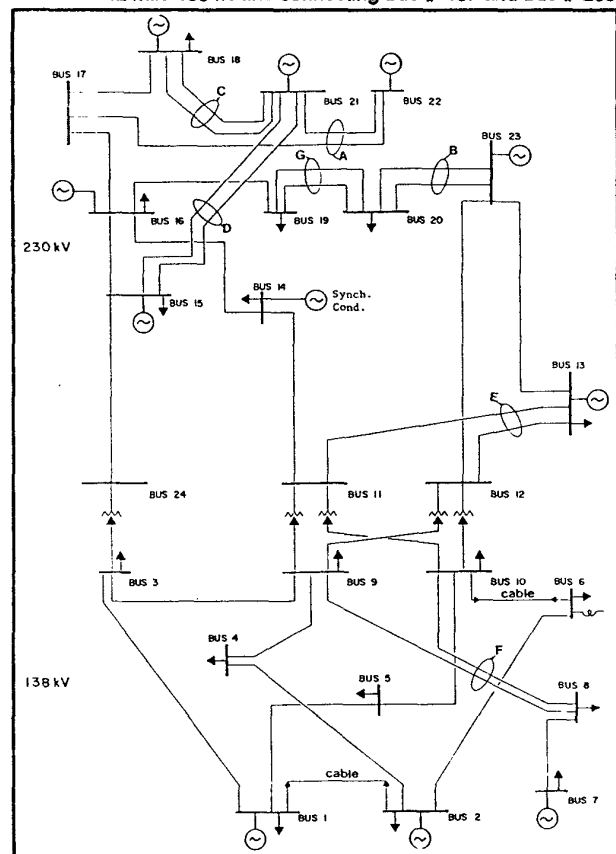

Figure 1 - IEEE One Area RTS-96

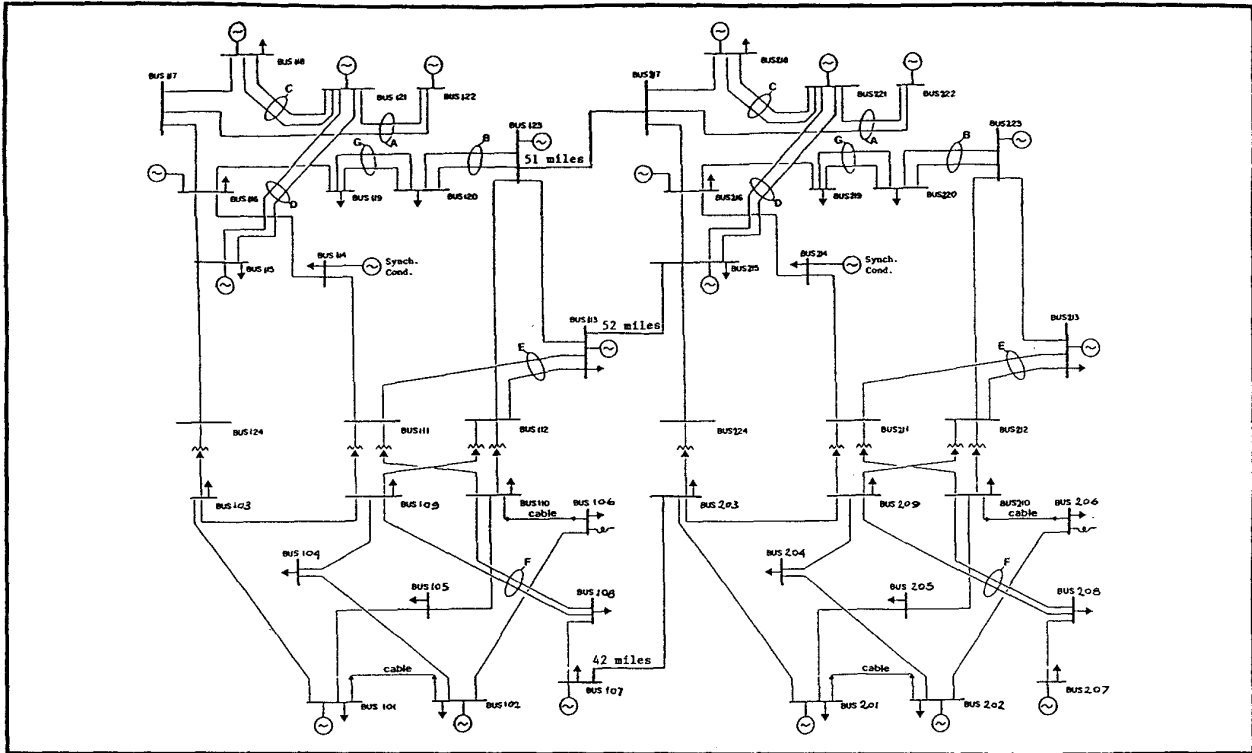

Figure 2 - IEEE Two Area RTS-96

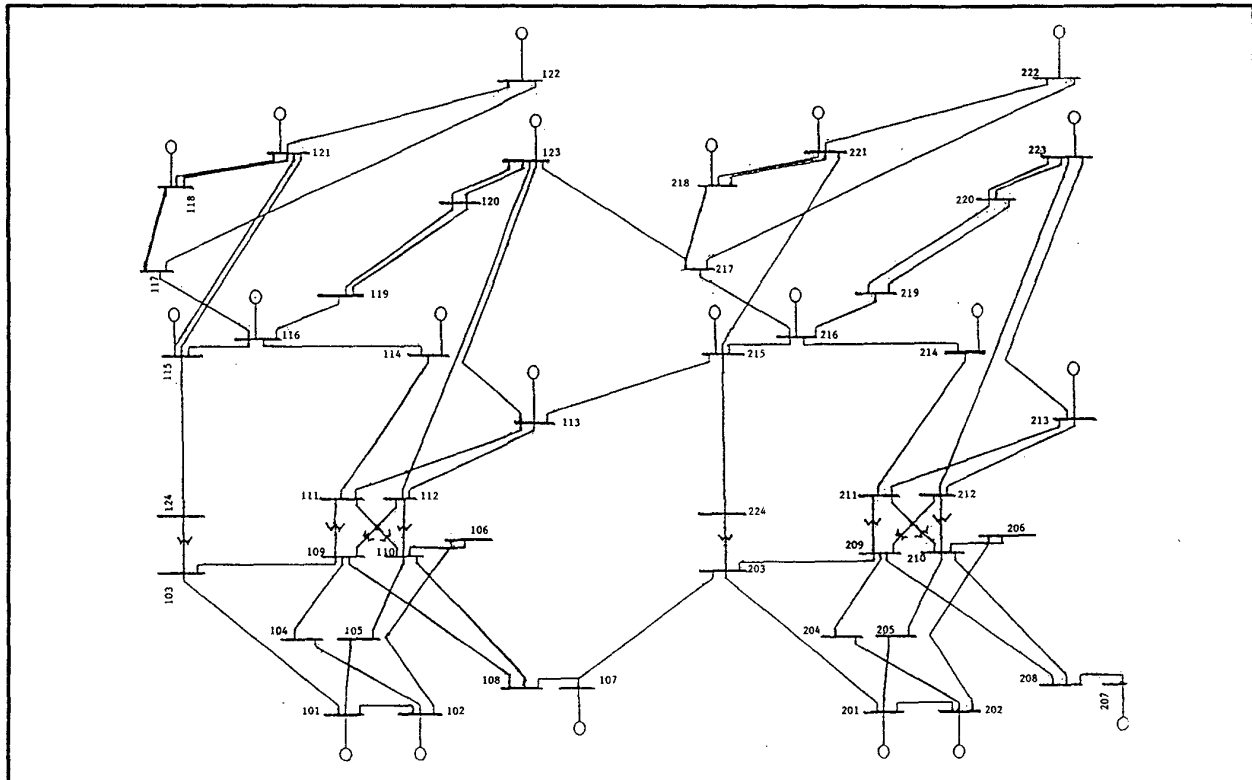

Figure 3 - IEEE Two Area RTS-96 with Geographic Scale

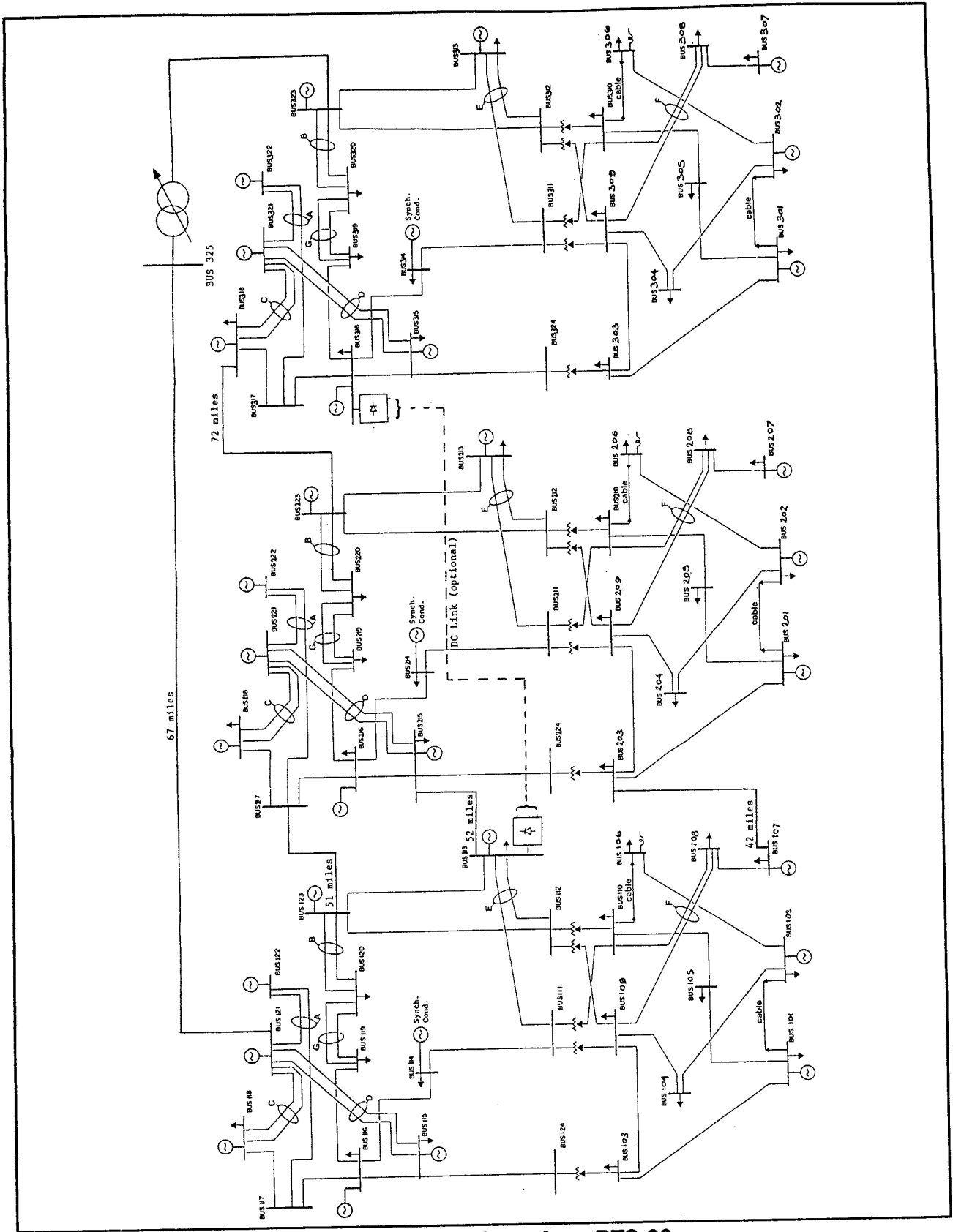

Figure 4 - IEEE Three Area RTS-96

Figure 3 shows relative geographic positions for the two-area system. Figure 4 shows a three-area system formed by adding a third single area "Area C" to the two-area system through two interconnections. A 72 mile 230 kV line connects "Area B" at bus 223 to "Area C" at bus # 318 and a 67 mile 230 kV line connects "Area A" at bus # 121 to "Area C" at bus # 325. A phase shift transformer has been added between buses # 325 and 323 in "Area C". An optional DC link connects "Area A" at bus # 113 to "Area C" at bus # 316.

BUS DATA

Except for the bus numbering system, the bus data has not changed from the RTS-79 data. Table 1 lists the bus data for the three areas. The buses for each area are numbered with a preassigned numbering system. For "Area A" the buses are labeled with numbers ranging from 101 through 124. For "Area B", the buses are labeled with numbers ranging from 201 through 224. While for "Area C" the buses are labeled with numbers ranging from 301 through 325. In addition, the three areas' buses are divided into subareas and zones. The bus load is assigned based on assumptions shown in Table 5.

Table 1 - IEEE RTS-96 Bus Data (3 Areas)

BUS #	BUS NAME	BUS TYPE	MW LOAD	MVAR LOAD	GL	BL	Sub Area	Base kv	Zone #
101	Abel	2	108	22	0	0	11	138	11
102	Adams	2	97	20	0	0	11	138	12
103	Adler	1	180	37	0	0	11	138	11
104	Agricola	1	74	15	0	0	11	138	11
105	Alken	1	71	14	0	0	11	138	11
106	Alber	1	136	28	0	1.0	11	138	12
107	Alder	2	125	25	0	0	11	138	12
108	Alger	1	171	35	0	0	11	138	12
109	Alf	1	175	36	0	0	11	138	13
110	Allen	1	195	40	0	0	11	138	13
111	Anna	1	0	0	0	0	11	230	13
112	Archer	1	0	0	0	0	11	230	13
113	Arne	3	265	54	0	0	12	230	14
114	Arnold	2	194	39	0	0	12	230	16
115	Arthur	2	317	64	0	0	12	230	16
116	Asser	2	100	20	0	0	12	230	16
117	Aston	1	0	0	0	0	12	230	17
118	Astor	2	333	68	0	0	12	230	17
119	Attar	1	181	37	0	0	12	230	15
120	Attila	1	128	26	0	0	12	230	15
121	Attlee	2	0	0	0	0	12	230	17
122	Aubrey	0	0	0	0	0	12	230	17
123	Austen	2	0	0	0	0	12	230	15
124	Avery	1	0	0	0	0	12	230	16
201	Bach	2	108	22	0	0	21	138	21
202	Bacon	2	97	20	0	0	21	138	22
203	Baffin	1	180	37	0	0	21	138	21
204	Bailey	1	74	15	0	0	21	138	21
205	Baln	1	71	14	0	0	21	138	21
206	Bajer	2	136	28	0	1.0	21	138	22
207	Baker	2	125	25	0	0	21	138	22
208	Balch	1	171	35	0	0	21	138	22
209	Balzac	1	175	36	0	0	21	138	23
210	Banks	1	195	40	0	0	21	138	23
211	Bardeen	1	0	0	0	0	21	230	23
212	Barkla	1	0	0	0	0	21	230	23
213	Barlow	2	265	54	0	0	22	230	24
214	Barry	2	194	39	0	0	22	230	26
215	Barton	2	317	64	0	0	22	230	26
216	Basov	2	100	20	0	0	22	230	26
217	Bates	1	0	0	0	0	22	230	27
218	Bayle	2	333	68	0	0	22	230	27
219	Bede	1	181	37	0	0	22	230	25
220	Beethoven	1	128	26	0	0	22	230	25
221	Behrting	2	0	0	0	0	22	230	27
222	Bell	2	0	0	0	0	22	230	27
223	Bloch	2	0	0	0	0	22	230	25
224	Bordet	1	0	0	0	0	22	230	26
301	Cabell	2	108	22	0	0	31	138	31
302	Cabot	2	97	20	0	0	31	138	32
303	Caesar	1	180	37	0	0	31	138	31
304	Calne	1	74	15	0	0	31	138	31
305	Calvin	1	71	14	0	0	31	138	31
306	Camus	1	136	28	0	1.0	31	138	32
307	Carew	2	125	25	0	0	31	138	32
308	Carrel	1	171	35	0	0	31	138	32
309	Carter	1	175	36	0	0	31	138	33
310	Caruso	1	195	40	0	0	31	138	33
311	Cary	1	0	0	0	0	31	230	33
312	Caxton	1	0	0	0	0	31	230	33
313	Cecil	2	265	54	0	0	32	230	34
314	Chain	2	194	39	0	0	32	230	36
315	Chase	2	317	64	0	0	32	230	36
316	Chifa	2	100	20	0	0	32	230	36
317	Chuhsl	1	0	0	0	0	32	230	37
318	Clark	2	333	68	0	0	32	230	37
319	Clay	1	181	37	0	0	32	230	35
320	Clive	1	128	26	0	0	32	230	35
321	Cobb	2	0	0	0	0	32	230	37
322	Cole	2	0	0	0	0	32	230	37
323	Comte	2	0	0	0	0	32	230	35
324	Curie	1	0	0	0	0	32	230	36
325	Curtiss	1	0	0	0	0	32	230	35

- Bus Type: 1 - Load Bus (no generation).
 2 - generator or plant bus.
 3 - swing bus.
- MW Load: load real power to be held constant.
 MVAR Load: load reactive power to be held constant.
 GL: real component of shunt admittance to ground.
 BL: imaginary component of shunt admittance to ground.

SYSTEM LOADS

Table 2 shows the weekly peak loads in percent of the annual peak. This seasonal load profile can be used to adapt to any system peaking season one desires to model. For example, if week number 1 is assumed to be the first week of the calendar year, then table 2 shows a winter peaking system with the peak occurring in the week prior to Christmas. If week number one is assumed to be the first week of August, then table 2 shows a summer peaking system with an assumed peak occurring in the month of July.

Table 3 shows the assumed daily peak load in percent of the weekly peak; while Table 4 shows the hourly load in percent of the daily peak (note that the week numbers corresponding to the seasons of the year can be reassigned depending on the climate zone that one wishes to model.)

Table 5 shows the assumed load for each bus of the three-area system.

Table 2 - Weekly Peak Load in Percent of Annual Peak

Week	Peak Load	Week	Peak Load
1	86.2	27	75.5
2	90.0	28	81.6
3	87.8	29	80.1
4	83.4	30	88.0
5	88.0	31	72.2
6	84.1	32	77.6
7	83.2	33	80.0
8	80.6	34	72.9
9	74.0	35	72.6
10	73.7	36	70.5
11	71.5	37	78.0
12	72.7	38	69.5
13	70.4	39	72.4
14	75.0	40	72.4
15	72.1	41	74.3
16	80.0	42	74.4
17	75.4	43	80.0
18	83.7	44	88.1
19	87.0	45	88.5
20	88.0	46	90.9
21	85.6	47	94.0
22	81.1	48	89.0
23	90.0	49	94.2
24	88.7	50	97.0
25	89.6	51	100.0
26	86.1	52	95.2

Table 3 - Daily Load in Percent of Weekly Peak

Day	Peak Load
Monday	93
Tuesday	100
Wednesday	98
Thursday	96
Friday	94
Saturday	77
Sunday	75

Table 4 - Hourly Peak Load in Percent of Daily Peak

Hour	winter weeks 1 -8 & 44 - 52		summer weeks 18 -30		spring/fall weeks 9-17 & 31 - 43	
	Wkdy	Wknd	Wkdy	Wknd	wkdy	wknd
	12-1 am	67	78	64	74	63
1-2	63	72	60	70	62	73
2-3	60	68	58	66	60	69
3-4	59	66	56	65	58	66
4-5	59	64	56	64	59	65
5-6	60	65	58	62	65	65
6-7	74	66	64	62	72	68
7-8	86	70	76	66	85	74
8-9	95	80	87	81	95	83
9-10	96	88	95	86	99	89
10-11	96	90	99	91	100	92
11-noon	95	91	100	93	99	94
noon-1pm	95	90	99	93	93	91
1-2	95	88	100	92	92	90
2-3	93	87	100	91	90	90
3-4	94	87	97	91	88	86
4-5	99	91	96	92	90	85
5-6	100	100	96	94	92	88
6-7	100	99	93	95	96	92
7-8	96	97	92	95	98	100
8-9	91	94	92	100	96	97
9-10	83	92	93	93	90	95
10-11	73	87	87	88	80	90
11-12	63	81	72	80	70	85

Table 5 - Bus Load Data

Bus number	Bus load	Load		If peak load 10% higher	
		% of System Load	MW	MVar	MW
101,201,301	3.8	108	22	118.8	24.2
102,202,302	3.4	97	20	106.7	22.0
103,203,303	6.3	180	37	198.0	40.7
104,204,304	2.6	74	15	81.4	16.5
105,205,305	2.5	71	14	78.1	15.4
106,206,306	4.8	136	28	149.6	30.8
107,207,307	4.4	125	25	137.5	27.5
106,208,308	6.0	171	35	188.1	38.5
109,209,309	6.1	175	36	192.5	39.6
110,210,310	6.8	195	40	214.5	44.0
113,213,313	9.3	265	54	291.5	59.4
114,214,314	6.8	194	39	213.4	42.9
115,215,315	11.1	317	64	348.7	70.4
116,216,316	3.5	100	20	110.0	22.0
118,218,318	11.7	333	68	366.3	74.8
119,219,319	6.4	181	37	199.1	40.7
120,220,320	4.5	128	26	140.8	28.6
Total	100.0	2850	580	3135	638

GENERATING UNITS

The major addition to this revision is the inclusion of production cost related data for the generating units. Unit start-up (hot and cold start) heat input, net plant incremental heat rates, unit cycling restrictions and ramping rates and unit emissions data have been included to facilitate system production cost calculations and emissions analysis. Table 6 shows the unit availability assumptions. Table 7 shows unit active and reactive power quantities used in the base-case load flow. Table 8 shows unit start-up heat input requirements. Table 9 shows the generating unit heat rates. Table 10 tabulates the unit's cycling restrictions and ramp rates while Table 11 shows the assumed unit emissions.

Table 6 - Generator Data

Unit group	Unit Size (MW)	Unit Type	Force Outage Rate	MTTF (Hour)	MTTR (Hour)	Scheduled Maint. wks/year
U12	12	Oil/Steam	0.02	2940	60	2
U20	20	Oil/CT	0.10	450	50	2
U50	50	Hydro	0.01	1980	20	2
U76	76	Coal/Steam	0.02	1960	40	3
U100	100	Oil/Steam	0.04	1200	50	3
U155	155	Coal/Steam	0.04	960	40	4
U197	197	Oil/Steam	0.05	950	50	4
U350	350	Coal/Steam	0.08	1150	100	5
U400	400	Nuclear	0.12	1100	150	6

Table 7 - Data of Generators at Each Bus

Bus ID	Unit Type	ID #	PG MW	QG MVAR	Q ^{max} MVAR	Q ^{min} MVAR	V _s pu
101	U20	1	10	0	10	0	1.035
101	U20	2	10	0	10	0	1.035
101	U76	3	76	14.1	30	-25	1.035
101	U76	4	76	14.1	30	-25	1.035
102	U20	1	10	0	10	0	1.035
102	U20	2	10	0	10	0	1.035
102	U76	3	76	7.0	30	-25	1.035
102	U76	4	76	7.0	30	-25	1.035
107	U100	1	80	17.2	60	0	1.025
107	U100	2	80	17.2	60	0	1.025
107	U100	3	80	17.2	60	0	1.025
113	U197	1	95.1	40.7	80	0	1.020
113	U197	2	95.1	40.7	80	0	1.020
113	U197	3	95.1	40.7	80	0	1.020
114	Sync Cond	1	0	13.7	200	-50	0.980
115	U12	1	12	0	6	0	1.014
115	U12	2	12	0	6	0	1.014
115	U12	3	12	0	6	0	1.014
115	U12	4	12	0	6	0	1.014
115	U12	5	12	0	6	0	1.014
115	U155	6	155	0.05	80	-50	1.014
116	U155	1	155	25.22	80	-50	1.017
118	U400	1	400	137.4	200	-50	1.050
121	U400	1	400	108.2	200	-50	1.050
122	U50	1	50	-4.96	16	-10	1.050
122	U50	2	50	-4.96	16	-10	1.050
122	U50	3	50	-4.96	16	-10	1.050
122	U50	4	50	-4.96	16	-10	1.050
122	U50	5	50	-4.96	16	-10	1.050
122	U50	6	50	-4.96	16	-10	1.050
123	U155	1	155	31.79	80	-50	1.050
123	U155	2	155	31.79	80	-50	1.050
123	U350	3	350	71.78	150	-25	1.050
201	U20	1	10	0	10	0	1.035
201	U20	2	10	0	10	0	1.035
201	U76	3	76	14.1	30	-25	1.035
201	U76	4	76	14.1	30	-25	1.035
202	U20	1	10	0	10	0	1.035
202	U20	2	10	0	10	0	1.035
202	U76	3	76	7.0	30	-25	1.035
202	U76	4	76	7.0	30	-25	1.035
207	U100	1	80	17.2	60	0	1.025
207	U100	2	80	17.2	60	0	1.025
207	U100	3	80	17.2	60	0	1.025
213	U197	1	95.1	40.7	80	0	1.020
213	U197	2	95.1	40.7	80	0	1.020
213	U197	3	95.1	40.7	80	0	1.020
214	Sync Cond	1	0	13.68	200	-50	0.980
215	U12	1	12	0	6	0	1.014
215	U12	2	12	0	6	0	1.014
215	U12	3	12	0	6	0	1.014
215	U12	4	12	0	6	0	1.014
215	U12	5	12	0	6	0	1.014
215	U155	6	155	0.048	80	-50	1.014

Table 7 (Continued)

Bus ID	Unit Type	ID #	PG MW	QG MVAR	Q ^{max} MVAR	Q ^{min} MVAR	V _s pu
216	U155	1	155	25.22	80	-50	1.017
218	U400	1	400	137.4	200	-50	1.050
221	U400	1	400	108.2	200	-50	1.050
222	U50	1	50	-4.96	16	-10	1.050
222	U50	2	50	-4.96	16	-10	1.050
222	U50	3	50	-4.96	16	-10	1.050
222	U50	4	50	-4.96	16	-10	1.050
222	U50	5	50	-4.96	16	-10	1.050
222	U50	6	50	-4.96	16	-10	1.050
223	U155	1	155	31.79	80	-50	1.050
223	U155	2	155	31.79	80	-50	1.050
223	U350	3	350	71.78	150	-25	1.050
301	U20	1	10	0	10	0	1.035
301	U20	2	10	0	10	0	1.035
301	U76	3	76	14.1	30	-25	1.035
301	U76	4	76	14.1	30	-25	1.035
302	U20	1	10	0	10	0	1.035
302	U20	2	10	0	10	0	1.035
302	U76	3	76	7.0	30	-25	1.035
302	U76	4	76	7.0	30	-25	1.035
307	U100	1	80	17.2	60	0	1.025
307	U100	2	80	17.2	60	0	1.025
307	U100	3	80	17.2	60	0	1.025
313	U197	1	95.1	40.7	80	0	1.02
313	U197	2	95.1	40.7	80	0	1.02
313	U197	3	95.1	40.7	80	0	1.02
314	Sync Cond	1	0	13.68	200	-50	0.98
315	U12	1	12	0	6	0	1.014
315	U12	2	12	0	6	0	1.014
315	U12	3	12	0	6	0	1.014
315	U12	4	12	0	6	0	1.014
315	U12	5	12	0	6	0	1.014
315	U155	6	155	0.048	80	-50	1.014
316	U155	1	155	25.22	80	-50	1.017
318	U400	1	400	137.4	200	-50	1.05
321	U400	1	400	108.2	200	-50	1.05
322	U50	1	50	-4.96	16	-10	1.05
322	U50	2	50	-4.96	16	-10	1.05
322	U50	3	50	-4.96	16	-10	1.05
322	U50	4	50	-4.96	16	-10	1.05
322	U50	5	50	-4.96	16	-10	1.05
322	U50	6	50	-4.96	16	-10	1.05
323	U155	1	155	31.79	80	-50	1.05
323	U155	2	155	31.79	80	-50	1.05
323	U350	3	350	71.78	150	-25	1.05

PG & QG: are the generating unit's real & reactive power output.
 Q^{max} & Q^{min}: are the limits of the unit's reactive power output.
 V_s: is the unit's regulated voltage set-point.

Table 8 - Unit Start-up Heat Input

Unit group	Unit Size (MW)	Unit Type	Hot Start (MBTU)	Cold Start (MBTU)
U12	12	Oil/Steam	38	68
U20	20	Oil/CT	5	5
U50	50	Hydro	N/A	N/A
U76	76	Coal/Steam	596	596
U100	100	Oil/Steam	250	566
U155	155	Coal/Steam	260	953
U197	197	Oil/Steam	443	775
U350	350	Coal/Steam	1,915	4,468
U400	400	Nuclear	N/A	N/A

Table 9 - Heat Rate and Incremental Heat Rate

Size mw	Type	Fuel	Output %	MW	Net Plant Heat Rate Btu/kwh	Incremental Heat Rate Calculated by continuous function Btu/kwh
12	Fossil Steam	#6 oil	20	2.40	16017	10179
			50	6.00	12500	10330
			80	9.60	11900	11668
			100	12.00	12000	13219
20	Combustion Turbine	#2 oil	79	15.80	15063	9859
			80	16.00	15000	10139
			99	19.80	14500	14272
			100	20.00	14499	14427
50	Hydro		100	50.00	Not applicable	
76	Fossil Steam	Coal	20	15.20	17107	9548
			50	38.00	12637	9966
			80	60.80	11900	11576
			100	76.00	12000	13311
100	Fossil Steam	#6 oil	25	25.00	12999	8089
			50	50.00	10700	8708
			80	80.00	10087	9420
			100	100.00	10000	9877
155	Fossil Steam	Coal	35	54.25	11244	8265
			60	93.00	10053	8541
			80	124.00	9718	8900
			100	155.00	9600	9381
197	Fossil Steam	#6 oil	35	68.95	10750	8348
			60	118.20	9850	8833
			80	157.60	9644	9225
			100	197.00	9600	9820
350	Fossil Steam	Coal	40	140.00	10200	8402
			65	227.50	9600	8896
			80	280.00	9500	9244
			100	350.00	9500	9768
400	Nuclear Steam	LWR	25	100.00	12751	8848
			50	200.00	10825	8965
			80	320.00	10170	9210
			100	400.00	10000	9438

NOTE The hydro units have 100% capacity for the first half of the year and 90% capacity for the remainder. Their quarterly energy distribution is as follows: 35%, 35%, 10%, 20%, where 100% is 200 GWh.

Table 10 - Unit Cycling Restriction and Ramping Rates

Unit group	Unit Size (MW)	Unit Type	Min. Down Time (Hr)	Min. Up Time (Hr)	Start Time Hot (Hr)	Start Time Cold (Hr)	Warm Star Time (Hr)	Ramp Rate MW/Min rate	
U12	12	Oil/ Steam	2	4	2	4	12	1	
U20	20	Oil/ CT	1	1	0	0	1	3	
U50	50	Hydro	N/A						
U76	76	Coal/ Steam	4	8	3	12	10	2	
U100	100	Oil/ Steam	8	8	2	7	60	7	
U155	155	Coal/ Steam	8	8	3	11	60	3	
U197	197	Oil/ Steam	10	12	4	7	24	3	
U350	350	Coal/3 Steam	48	24	8	12	96	4	
U400	400	Nuclear	1	1	N/A	N/A	N/A	20	

Table 11 - Unit Emissions Data

IEEE-RTS unit group	U20	U12,U100,U197	U76,U155,U350
Unit type	GT	ST	ST
Fuel type	FO2	FO6	Bituminous Coal
Fuel sulfur content (%)	0.2	Unit-Specific	Unit-specific
Emissions Rate			
SO2 (Lbs/MMBTU)	0.2	Unit-specific	Unit-specific
NOX (Lbs/MMBTU)	0.5	0.5	Unit-specific
Part (Lbs/MMBTU)	0.036	0.1	Unit-specific
CO2 (Lbs/MMBTU)	160	170	210
CH4 (Lbs/MMBTU)	0.002	0.002	0.001
N2O(Lbs/MMBTU)	0.004	0.004	0.004
CO (Lbs/MMBTU)	0.11	0.04	0.02
VOCs (Lbs/MMBTU)	0.04	0.007	0.003

TRANSMISSION SYSTEM

The RTS-79 is expanded to include a phase shifter, a two terminal DC transmission line, and five inter-area ties. Table 12 shows the transmission branch data; this includes lines, cables, transformers, phase-shifter, and tie-lines. All pu quantities are on 100 MVA base. Areas A and B may be further interconnected by a DC link, based upon reference [3]. Table 13 shows the two-terminal DC transmission line data.

Table 12 - Branch Data

ID# = Branch identifier.
 Inter area branches are indicated by double letter ID.
 Circuits on a common tower have hyphenated ID#.
 λp = Permanent Outage Rate (outages/year).
 Dur = Permanent Outage Duration (Hours).
 λt = Transient Outage Rate (outages/year).
 Con = Continuous rating.
 LTE = Long-time emergency rating (24 hour).
 STE = Short-time emergency rating (15 minute).
 Tr = Transformer off-nominal ratio.
 Transformer branches are indicated by Tr ≠ 0.

ID #	From Bus	To Bus	L miles	-Perm- λp	Tran- Dur	R pu	X pu	B pu	Con MVA	LTE MVA	STE MVA	Tr	
A1	101	102	3	.24	16	0.0	0.003	0.014	0.461	175	193	200	0
A2	101	103	55	.51	10	2.9	0.055	0.211	0.057	175	208	220	0
A3	101	105	22	.33	10	1.2	0.022	0.085	0.023	175	208	220	0
A4	102	104	33	.39	10	1.7	0.033	0.127	0.034	175	208	220	0
A5	102	106	50	.48	10	2.6	0.050	0.192	0.052	175	208	220	0
A6	103	109	31	.38	10	1.6	0.031	0.119	0.032	175	208	220	0
A7	103	124	0	.02	768	0.0	0.002	0.084	0	400	510	600	1.015
A8	104	109	27	.36	10	1.4	0.027	0.104	0.028	175	208	220	0
A9	105	110	23	.34	10	1.2	0.023	0.088	0.024	175	208	220	0
A10	106	110	16	.33	35	0.0	0.014	0.061	2.459	175	193	200	0
A11	107	108	33	.44	10	2.2	0.042	0.161	0.044	175	208	220	0
A12-1	108	109	43	.44	10	2.3	0.043	0.165	0.045	175	208	220	0
A13-2	108	110	43	.44	10	2.3	0.043	0.165	0.045	175	208	220	0
A14	109	111	0	.02	768	0.0	0.002	0.084	0	400	510	600	1.03
A15	109	112	0	.02	768	0.0	0.002	0.084	0	400	510	600	1.03
A16	110	111	0	.02	768	0.0	0.002	0.084	0	400	510	600	1.015
A17	110	112	0	.02	768	0.0	0.002	0.084	0	400	510	600	1.015
A18	111	113	33	.40	11	0.8	0.006	0.048	0.100	500	600	625	0
A19	111	114	29	.39	11	0.7	0.005	0.042	0.088	500	600	625	0
A20	112	113	33	.40	11	0.8	0.006	0.048	0.100	500	600	625	0
A21	112	123	67	.52	11	1.6	0.012	0.097	0.203	500	600	625	0
A22	113	123	60	.49	11	1.5	0.011	0.097	0.182	500	600	625	0
A23	113	215	52	.47	11	1.0	0.011	0.075	0.158	500	600	625	0
A24	114	118	27	.38	11	0.7	0.005	0.059	0.082	500	600	625	0
A25-1	115	121	34	.41	11	0.8	0.006	0.049	0.103	500	600	625	0
A25-2	115	121	34	.41	11	0.8	0.006	0.049	0.103	500	600	625	0
A26	115	124	36	.41	11	0.9	0.007	0.052	0.109	500	600	625	0
A27	116	117	18	.35	11	0.4	0.003	0.026	0.055	500	600	625	0
A28	116	119	16	.34	11	0.4	0.003	0.023	0.049	500	600	625	0
A29	117	118	10	.32	11	0.2	0.002	0.014	0.030	500	600	625	0
A30	117	122	73	.54	11	1.8	0.014	0.105	0.221	500	600	625	0
A31-1	118	121	18	.35	11	0.4	0.003	0.026	0.055	500	600	625	0
A31-2	118	121	18	.35	11	0.4	0.003	0.026	0.055	500	600	625	0
A32-1	119	120	27.5	.38	11	0.7	0.005	0.040	0.083	500	600	625	0
A32-2	119	120	27.5	.38	11	0.7	0.005	0.040	0.083	500	600	625	0
A33-1	120	123	15	.34	11	0.4	0.003	0.022	0.046	500	600	625	0
A33-2	120	123	15	.34	11	0.4	0.003	0.022	0.046	500	600	625	0
A34	121	122	47	.45	11	1.2	0.009	0.068	0.142	500	600	625	0
AB3	123	217	51	.46	11	1.3	0.010	0.074	0.155	500	600	625	0
B1	201	202	3	.24	16	0.0	0.003	0.014	0.461	175	193	200	0
B2	201	203	55	.51	10	2.9	0.055	0.211	0.057	175	208	220	0
B3	201	205	22	.33	10	1.2	0.022	0.085	0.023	175	208	220	0
B4	202	204	33	.39	10	1.7	0.033	0.127	0.034	175	208	220	0
B5	202	206	50	.48	10	2.6	0.050	0.192	0.052	175	208	220	0
B6	203	209	31	.38	10	1.6	0.031	0.119	0.032	175	208	220	0
B7	203	224	0	.02	768	0.0	0.002	0.084	0	400	510	600	1.015
B8	204	209	27	.36	10	1.4	0.027	0.104	0.028	175	208	220	0
B9	205	210	23	.34	10	1.2	0.023	0.088	0.024	175	208	220	0
B10	206	210	16	.33	35	0.0	0.014	0.061	2.459	175	193	200	0
B11	207	208	16	.30	10	0.8	0.016	0.061	0.017	175	208	220	0
B12-1	208	209	43	.44	10	2.3	0.043	0.165	0.045	175	208	220	0
B13-2	208	210	43	.44	10	2.3	0.043	0.165	0.045	175	208	220	0
B14	209	211	0	.02	768	0.0	0.002	0.084	0	400	510	600	1.03
B15	209	212	0	.02	768	0.0	0.002	0.084	0	400	510	600	1.03
B16	210	211	0	.02	768	0.0	0.002	0.084	0	400	510	600	1.015
B17	210	212	0	.02	768	0.0	0.002	0.084	0	400	510	600	1.015
B18	211	213	33	.40	11	0.8	0.006	0.048	0.100	500	600	625	0
B19	211	214	29	.39	11	0.7	0.005	0.042	0.088	500	600	625	0
B20	212	213	33	.40	11	0.8	0.006	0.048	0.100	500	600	625	0
B21	212	223	67	.52	11	1.6	0.012	0.097	0.203	500	600	625	0
B22	213	223	60	.49	11	1.5	0.011	0.097	0.182	500	600	625	0
B23	214	223	60	.49	11	1.0	0.011	0.075	0.158	500	600	625	0
B24	215	216	12	.33	11	0.3	0.002	0.017	0.036	500	600	625	0
B25-1	215	221	34	.41	11	0.8	0.006	0.049	0.103	500	600	625	0
B25-2	215	221	34	.41	11	0.8	0.006	0.049	0.103	500	600	625	0
B26	215	224	36	.41	11	0.9	0.007	0.052	0.109	500	600	625	0
B27	216	217	18	.35	11	0.4	0.003	0.026	0.055	500	600	625	0
B28	216	219	16	.34	11	0.4	0.003	0.023	0.049	500	600	625	0
B29	217	218	10	.32	11	0.2	0.002	0.014	0.030	500	600	625	0
B30	217	222	73	.54	11	1.8	0.014	0.105	0.221	500	600	625	0
B31-1	218	221	18	.35	11	0.4	0.003	0.026	0.055	500	600	625	0
B31-2	218	221	18	.35	11	0.4	0.003	0.026	0.055	500	600	625	0
B32-1	219	220	27.5	.38	11	0.7	0.005	0.040	0.083	500	600	625	0
B32-2	219	220	27.5	.38	11	0.7	0.005	0.040	0.083	500	600	625	0
B33-1	220	223	15	.34	11	0.4	0.003	0.022	0.046	500	600	625	0
B33-2	220	223	15	.34	11	0.4	0.003	0.022	0.046	500	600	625	0
B34	221	222	47	.45	11	1.2	0.009	0.068	0.142	500	600	625	0

Table 12 (Continued)

ID #	From Bus	To Bus	L miles	-Perm- λp	Tran- Dur	R pu	X pu	B pu	Con MVA	LTE MVA	STE MVA	Tr	
C1	301	302	3	.24	16	0.0	0.003	0.014	0.461	175	193	200	0
C2	301	303	55	.51	10	2.9	0.055	0.211	0.057	175	208	220	0
C3	301	305	22	.33	10	1.2	0.022	0.085	0.023	175	208	220	0
C4	302	304	33	.39	10	1.7	0.033	0.127	0.034	175	208	220	0
C5	302	306	50	.48	10	2.6	0.050	0.192	0.052	175	208	220	0
C6	303	309	31	.38	10	1.6	0.031	0.119	0.032	175	208	220	0
C7	303	324	0	.02	768	0.0	0.002	0.084	0	400	510	600	1.015
C8	304	309	27	.36	10	1.4	0.027	0.104	0.028	175	208	220	0
C9	305	310	23	.34	10	1.2	0.023	0.088	0.024	175	208	220	0
C10	306	310	16	.33	35	0.0	0.014	0.061	2.459	175	193	200	0
C11	307	308	16	.30	10	0.8	0.016	0.061	0.017	175	208	220	0
C12-1	308	309	43	.44	10	2.3	0.043	0.165	0.045	175	208	220	0
C13-2	308	310	43	.44	10	2.3	0.043	0.165	0.045	175	208	220	0
C14	309	311	0	.02	768	0.0	0.002	0.084	0	400	510	600	1.03
C15	309	312	0	.02	768	0.0	0.002	0.084	0	400	510	600	1.03
C16	310	311	0	.02	768	0.0	0.002	0.084	0	400	510	600	1.015
C17	310	312	0	.02	768	0.0	0.002	0.084	0	400	510	600	1.015
C18	311	313	33	.40	11	0.7	0.005	0.042	0.088	500	600	625	0
C19	311	314	29	.39	11	0.7	0.005	0.040	0.083	500	600	625	0
C20	311	314	29	.39	11	0.8	0.006	0.048	0.100	500	600	625	0
C21	312	323	67	.52	11	1.6	0.012	0.097	0.203	500	600	625	0
C22	313	323	60	.49	11	1.5	0.011	0.087	0				

Table 13 (Continued)

The terminal equipment will have the following capacity table:

Capacity (%)	Prob	λ (event/yr)	Dur. (hr.)
0 \leq capacity < 50	0.0179	6.03	26.00
50 \leq capacity < 75	0.0747	54.97	11.90
75 \leq capacity < 100	0.0007	1.08	5.77
Capacity = 100	0.9067	52.88	150.20

SUBSTATION

Substation data, based on reference [4], has been added to RTS-96. Figure 5 shows a single line diagram of the substations. Table 14 lists the failure rates and maintenance requirements of a substation breaker and switching time requirements for various components.

Table 14 - Data for Terminal Stations
(Based on reference 4)

Active failure rate of a breaker (failure/year)	=	0.0066
Passive failure rate of a breaker (failure/year)	=	0.0005
Maintenance rate of a breaker (outages/year)	=	0.2
Maintenance time of a breaker (hours)	=	108
Switching time - one or more components (hours)	=	1.0

SYSTEM DYNAMIC DATA

Table 15 contains the system dynamic data, which was taken from reference [5]. It is based on the following: a classical model is assumed for each generator, reactance and inertia data are typical of generators of the same type and the same size, reactance values are based on the given MVA base, and inertia values are based on the unit size in MW.

Table 15 - System Dynamic Data
(based on reference 5)

Unit group	Unit size MW	Unit Type	MVA Base	Unit pu	Reactance		
					Transformer pu	Inertia MJ/MW	Damping Ratio
U12	12	Oil/Steam	14	0.32	0.13	2.8	0.0
U20	20	Oil/CT	24	0.32	0.13	2.8	0.0
U50	50	Hydro	53	0.28	0.1	3.5	0.0
U76	76	Coal/Steam	89	0.3	0.13	3.0	0.0
U100	100	Oil/Steam	118	0.32	0.13	2.8	0.0
U155	155	Coal/Steam	182	0.3	0.13	3.0	0.0
U197	197	Oil/Steam	232	0.32	0.13	2.8	0.0
U350	350	Coal/Steam	412	0.3	0.13	3.0	0.0
U400	400	Nuclear	471	0.4	0.15	5.0	0.0

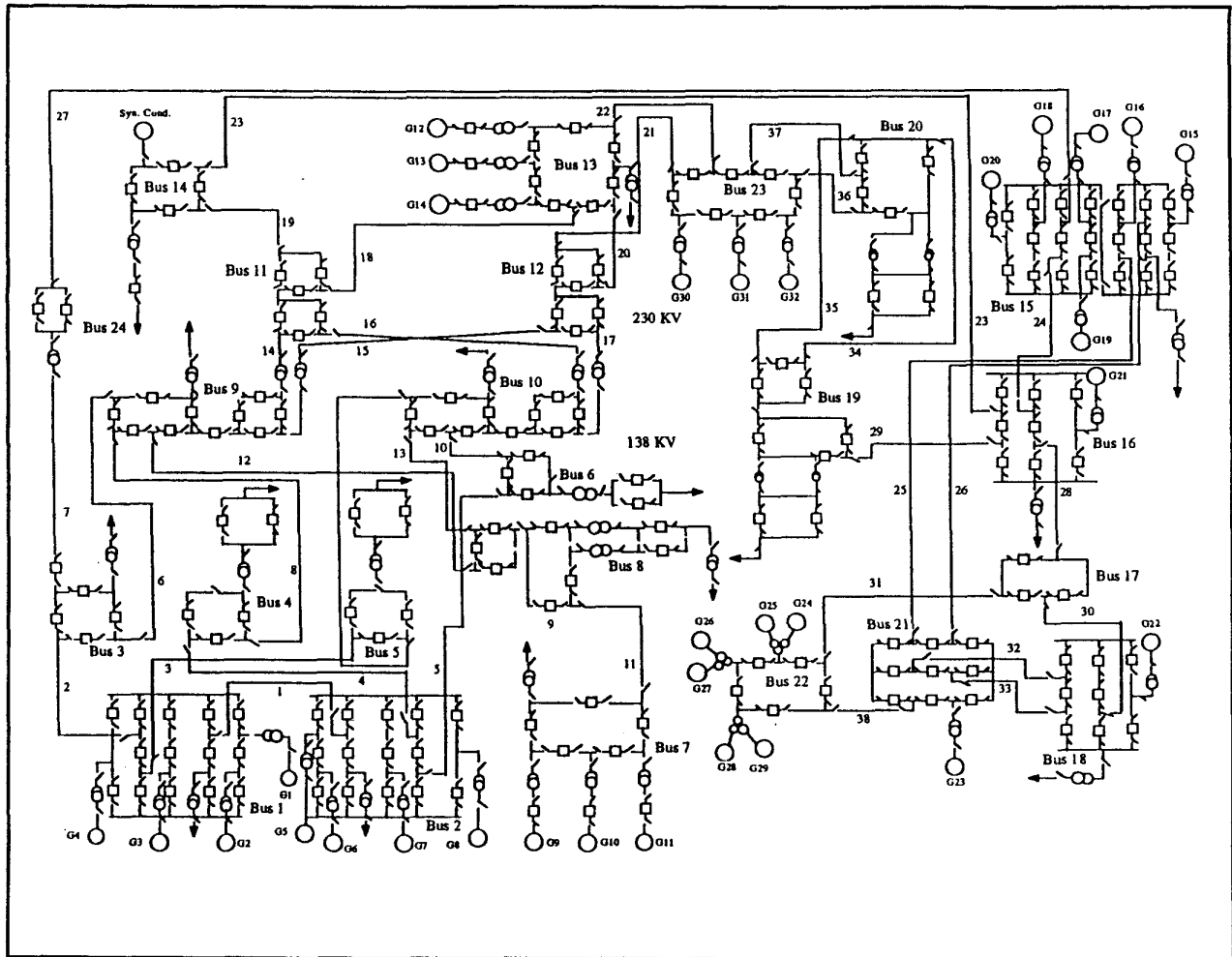

Figure 5 - Single Line Diagram of IEEE One Area RTS-96 Substation System

CONCLUSIONS

The Reliability Test System has been extended by adding a number of enhancements; these should be considered to be "optional" additions and no user should feel compelled to make use of them all. One-, Two-, and Three-Area systems have been presented, it is anticipated that one will be more suitable than the others for a particular application and it is up to the user to make a choice. Likewise, the inclusion of a DC link will not be appropriate for all applications.

Numerous load-flow configurations were reviewed during the development of RTS-96 and it is felt that the proposed systems present reasonable planning and operating scenarios. Loads are quite secure with all elements in service, but special operating strategies may be required when critical elements are removed.

This paper has presented data which is required by reliability models of power systems in use at the time of writing. It is expected that future models may require other parameters, and the authors of such future models are encouraged to choose values which are consistent with the values of parameters which are tabulated in this revision of the RTS.

REFERENCES

1. IEEE RTS Task Force of APM Subcommittee, "IEEE Reliability Test System", IEEE PAS, Vol-98, No. 6, Nov/Dec. 1979, pp 2047-2054.
2. R.N. Allan, R. Billinton and N.M.K. Abdel-Gavad, "The IEEE Reliability Test System - Extensions to and Evaluation of the Generating System", IEEE Trans. on Power Systems, Vol. PWRS-1, pp 1-7, Nov. 1986.
3. R. Billinton and D.S. Ahluwalia, "Incorporation of a DC Link in a Composite System Adequacy Assessment - Composite System Analysis", IEE Proc. C, Vol. 139, No. 3, May 1992.
4. R. Billinton, P.K. Vohra and Sudhir Kumar, "Effect of Station Originated Outages in a Composite System Adequacy Evaluation of the IEEE Reliability Test System", IEEE PAS, Vol-104, No. 10, Oct. 1985, pp 2649-2656.
5. B. Poretta, D.L. Kiguel, G.A. Hamoud and E.G. Neudorf, "A Comprehensive Approach for Adequacy and Security Evaluation of Bulk Power Systems", IEEE Trans. on Power Systems, PWRS, May 1991, pp 433-441.

BIOGRAPHIES

Cliff Grigg (Senior Member) is Associate Dean of the Faculty and Professor of Electrical and Computer Engineering at Rose-Hulman Institute of Technology, Terre Haute, IN.

Peter Wong (Member) is Manager - Operations Planning and Procedures, NEPEX, Holyoke, MA.

Paul Albrecht (Fellow) is a consultant, Clifton Park, NY, and was formerly with GE, Schenectady, NY.

Ron Allan (Fellow) is Professor of Electric Energy Systems at UMIST, Manchester, UK.

Murty Bhavaraju (Fellow) is Manager - Long Range Resource Planning, Public Service Electric & Gas, Newark, NJ.

Roy Billinton (Fellow) is Associate Dean of Graduate Studies, Research and Extension, and C.J. McKenzie Professor of Electrical Engineering at the University of Saskatchewan, Saskatoon, Canada.

Quan Chen (Member) is Engineer - Power Supply Planning, NEPLAN, Holyoke, MA.

Clement Fong (Senior Member) is Section Head - Operations, Ontario Hydro, Toronto, Canada.

Suheil Haddad (Member) is Manager - Electrical Analytical Division, Sargent & Lundy, Chicago, IL.

Sastry Kuruganty (Senior Member) is Professor of Electrical Engineering at the University of North Dakota, Grand Forks, ND.

Wenyuan Li is (Senior Member) Senior Engineer - Analytic Studies, BC Hydro, Vancouver, Canada.

Rana Mukerji (Member) is Program Manager, GE, Schenectady, NY.

Dee Patton (Fellow) is Head of Electrical Engineering Department, Texas A&M University, College Station, TX.

Narayan Rau (Senior Member) is Principal Utility Planner, NREL, Golden, CO.

Dag Reppen (Fellow) is Manager - Reliability and Security, Power Technologies Inc., Schenectady, NY.

Alex Schneider (Senior Member) is Reliability Engineer, MAIN Coordination Center, Lombard, IL.

Mohammed Shahidehpour (Senior Member) is Dean of Graduate Studies and Research, IIT, Chicago, IL.

Chanan Singh (Fellow) is Professor of Electrical Engineering at Texas A&M University, College Station, TX.

Discussion

A. W. Schneider, Jr. (MAIN Coordination Center, Lombard IL):

The effort to enhance and extend the IEEE Reliability Test System (RTS) has taken over six years and benefitted from the suggestions of numerous present and former members of the Application of Probability Methods subcommittee. As a member of the task force during the final year of this revision, I regret that the following points came to my attention too late for consideration in preparing the paper for submission. They are offered for three reasons: to eliminate changes from the 1979 RTS which would invalidate comparisons with applications of the latter, to insure that the new data presented will completely specify a base case load flow, and to suggest more economical and reliable bus configurations which will avoid distortions to the reliability indices of the RTS.

Unexplained Changes from the 1979 RTS to the Present Paper

1. Both fuel and O & M cost data have been deleted. A major objective of the current revision was to improve data concerning the generating units.

2. Changes have been made to the heat rate data (old Table 5, new Table 9) which will complicate comparisons based on the old and new RTS even if the analytical method under consideration does not depend on new features. Changes to data in the previous RTS should be made only if the former values are internally inconsistent, in which case an explicit statement should be made. A substitute Table 9, presented at the end of this discussion, is proposed to restore all heat rates shown in the 1979 RTS to their original values and to assume the incremental heat rate between the output values shown is constant. It should be noted that only two output levels, 80% and 100%, were shown for combustion turbines in the 1979 RTS. Values which have changed from those shown in Table 9 of the paper are italicized

Incomplete Data for Load Flow, Stability and/or Reliability Studies

1. For the phase shifter, the minimum and maximum shift and the desired MW flow (or the angle, if flow is not controlled) are essential data. I propose a range of +10 to -10 degrees. Since the generators at corresponding buses of different areas have identical watt and var generation, a net interchange of 0 for each area is implied. The flows specified for the phase shifter, and the optional DC line, if present, will determine whether the loads, generation and voltages shown in Tables 1 and 7 can all be achieved in a solved case.

2. The capacity of the optional DC line should be shown in Table 13.

3. The tap ratio of the generator stepup transformers should be specified in Table 15 or a footnote, even if unity is intended.

4. Figure 5 has two omissions which must be resolved to define a valid RTS configuration.

- The connection of the 100 MVA reactor at bus 6 is not shown.
- The configurations of buses 3, 7, 13, 15, 17, 18, 21, and 23 make no provision for inter area tie line terminations, which do not appear in corresponding buses in every area.

5. No outage nor restoration rates are provided for the transformers supplying load, whether 230 kV or 138 kV. Specifying their impedances, tap ratios, and load tap changing characteristics would be a desirable addition.

Costly and/or unreliable bus configurations

Several of the substation configurations are more complex (hence, costly) than is needed and at the same time less reliable than simpler alternatives. While it need not be a goal of the RTS to present an optimum configuration at each bus, it is reasonable to avoid redundant breakers and unnecessary exposure to loss of all sources or all outlets to a bus from a single fault. Such exposure may distort the contribution to reliability indices of untypical failure modes.

- An unneeded line breaker connects line 7 to bus 3.
- Distribution system (under 138 kV) data is not generally provided by the RTS. A consistent technique of either showing transformers feeding load, as at bus 15, or omitting them as at bus 20, should be adopted. Paralleled breakers and/or transformers, as at buses 6 and 8, raise issues for which the RTS data is completely inadequate.
- The configurations of buses 9-12 are unnecessarily complex and unreliable. All these buses have the "supplies" grouped on one side of a critical element and the "loads" grouped on the other side. Loss of the common element will result in total interruption of supply from the 230 kV to the 138 kV system through the affected bus. Configuring each of these buses as a simple ring bus would be less costly and more reliable.
- Similarly, bus 8 has its sources from buses 9 and 10 grouped together and is susceptible to isolation by a single event.
- At bus 22, exchanging the connection of G26 and G27 with line 38 would eliminate the possibility of all generation at this station being lost from a single fault on a breaker.

Table 9 - Heat Rate and Incremental Heat Rate

Size MW	Type	Fuel	Output		Plant Heat Rate, BTU/kWh	
			%	MW	Net	Incremental
12	Fossil Steam	#6 oil	20	2.4	15600	11100
			50	6.0	12900	10233
			80	9.6	11900	12400
			100	12.0	12000	
20	Combustion Turbine	#2 oil	70	14.0	15250	13250
			80	16.0	15000	12750
			90	18.0	14750	12250
			100	20.0	14500	
50	Hydro	Not applicable				
76	Fossil Steam	Coal	20	15.2	15600	11100
			50	38.0	12900	10233
			80	60.8	11900	12400
			100	76.0	12000	
100	Fossil Steam	#6 oil	25	25.0	13000	8600
			55	55.0	10600	9000
			80	80.0	10100	9600
			100	100.0	10000	
155	Fossil Steam	Coal	35	54.3	11200	8560
			60	93.0	10100	8900
			80	124.0	9800	9300
			100	155.0	9700	
197	Fossil Steam	#6 oil	35	69.0	10750	8590
			60	118.2	9850	9810
			80	157.6	9840	8640
			100	197.0	9600	
350	Fossil Steam	Coal	40	140.0	10200	8640
			65	227.5	9600	9067
			80	280.0	9500	9500
			100	350.0	9500	
400	Nuclear Steam	LWR	25	100.0	12550	9100
			50	200.0	10825	9078
			80	320.0	10170	9320
			100	400.0	10000	

Reliability Test System Task Force :

The task force thanks Mr. Schneider for his insightful comments and additions to the RTS.

The alternative table 9 will allow comparisons to be made with the former system while the "official" table 9 can be used for future studies.

The proposed range of $\pm 10^\circ$ for the phase shifter seems reasonable, as does a tap ratio of unity for the generator step-up transformers.

Manuscript received January 26, 1999.