



CprE 281: Digital Logic

Instructor: Alexander Stoytchev

<http://www.ece.iastate.edu/~alexs/classes/>

Analysis of Synchronous Sequential Circuits

*CprE 281: Digital Logic
Iowa State University, Ames, IA
Copyright © Alexander Stoytchev*

Administrative Stuff

- **Homework 11 is due on Nov 26**

Administrative Stuff

- **Final Project (7% of your grade)**
- **By now you should have selected a project**
- **Also, posted on the class web page (Labs section)**
- **This is your lab for the last two weeks**
- **This is due during your last lab (dead week)**

Goal for Today's Lecture

- **Given a circuit diagram for a synchronous sequential circuit, the goal is to figure out the FSM**
- **Figure out the present state variables, the next state variables, the state-assigned table, the state table, and finally the state diagram.**
- **In other words, the goal is to reverse engineer the circuit.**

What does this circuit do?

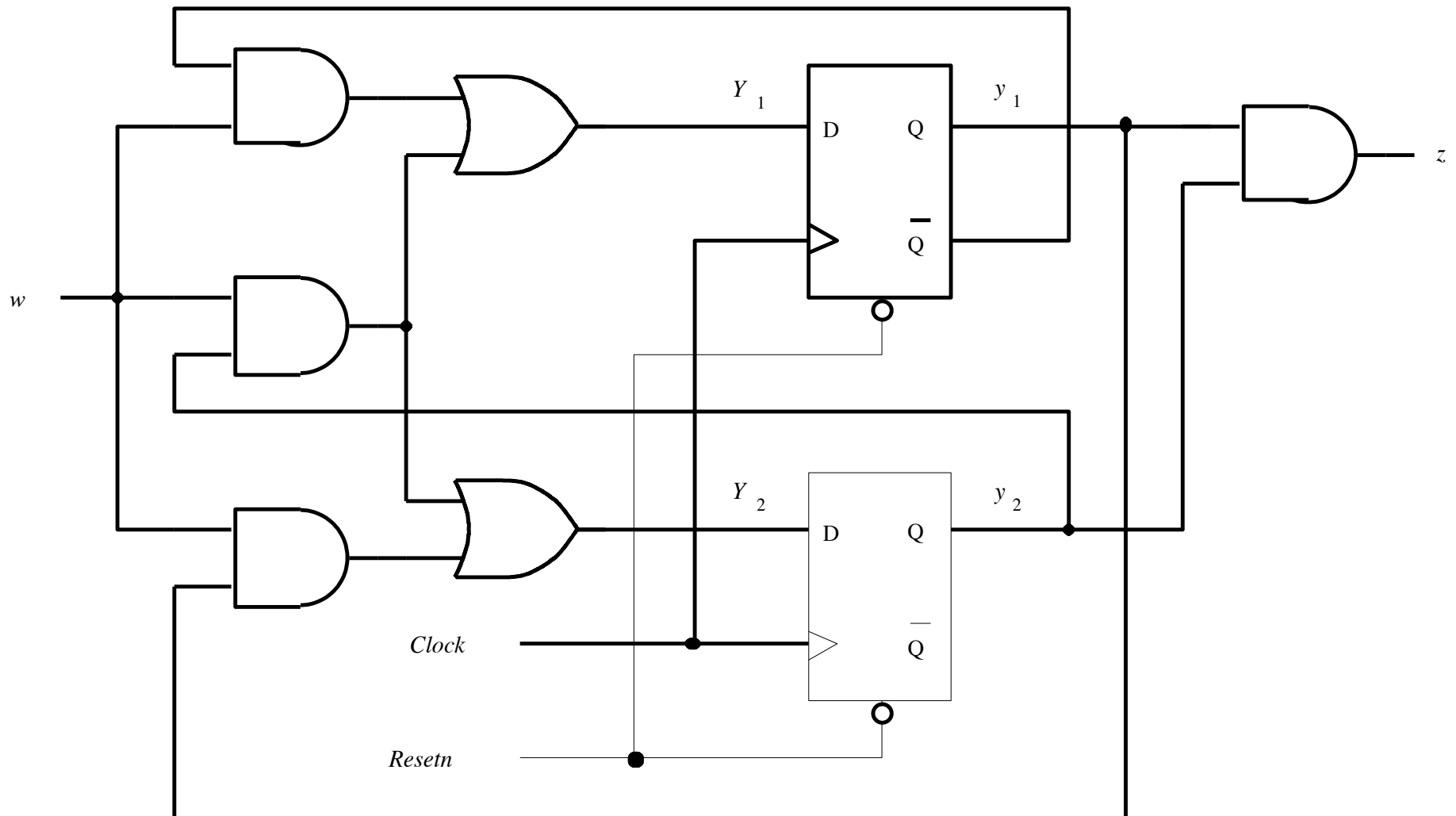

[Figure 6.75 from the textbook]

Approach

- **Find the flip-flops**
- **Outputs of the flip-flops = present state variables**
- **Inputs of the flip-flops determine the next state variables**
- **Determine the logical expressions for the outputs**
- **Given this info it is easy to do the state-assigned table**
- **Next do the state table**
- **Finally, draw the state diagram.**

Where are the inputs?

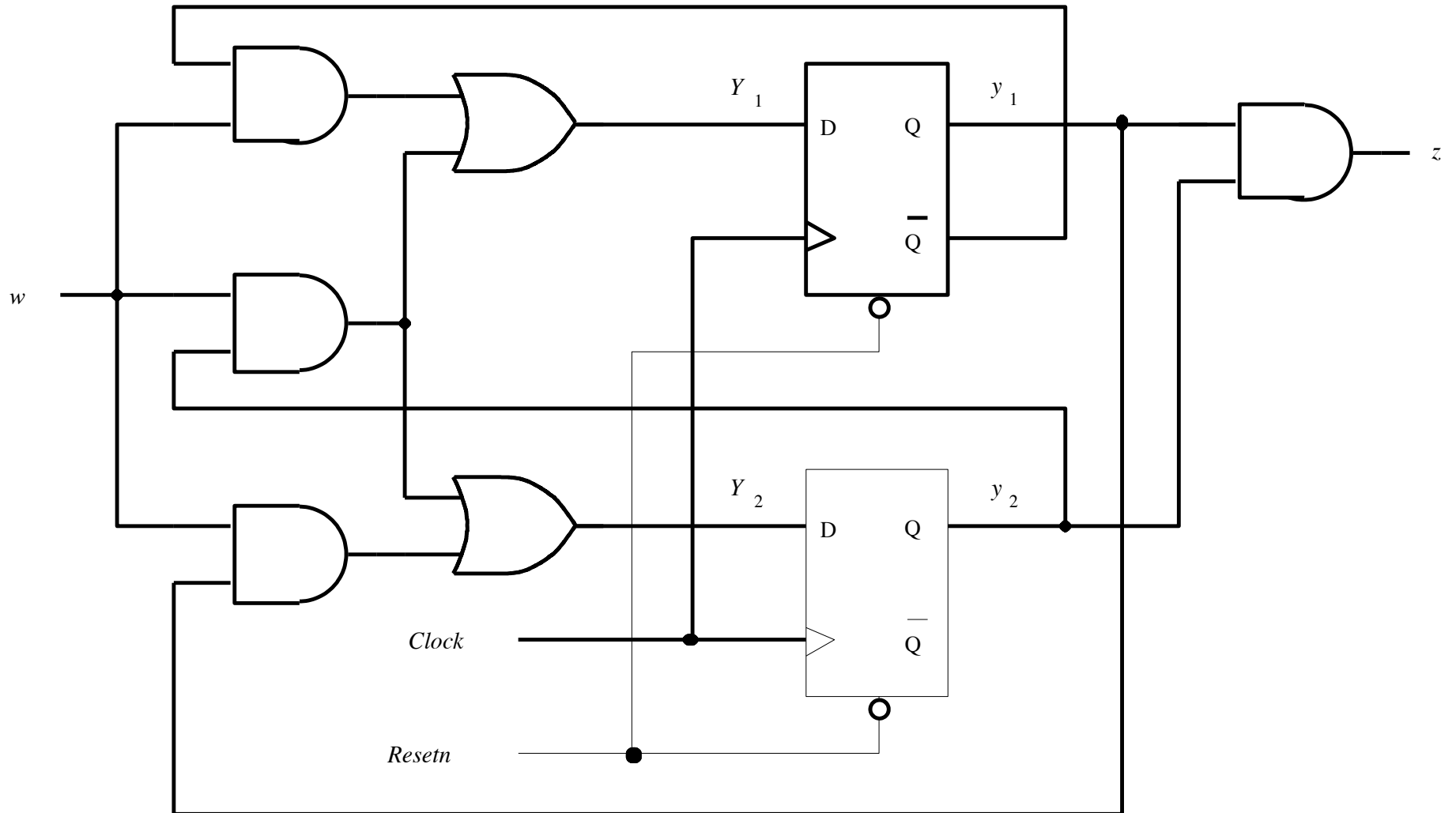

[Figure 6.75 from the textbook]

Where are the inputs?

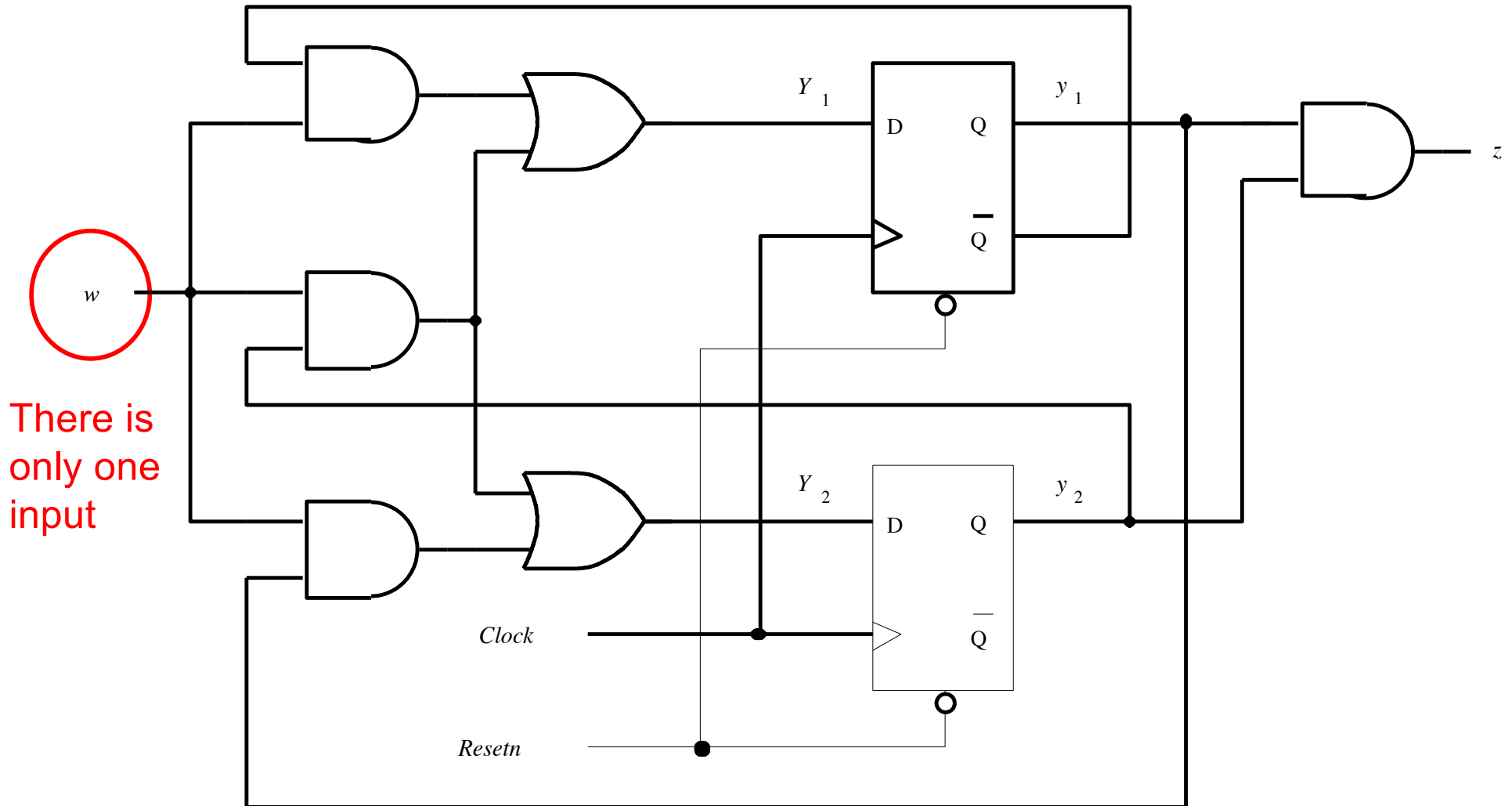

[Figure 6.75 from the textbook]

Where are the outputs?

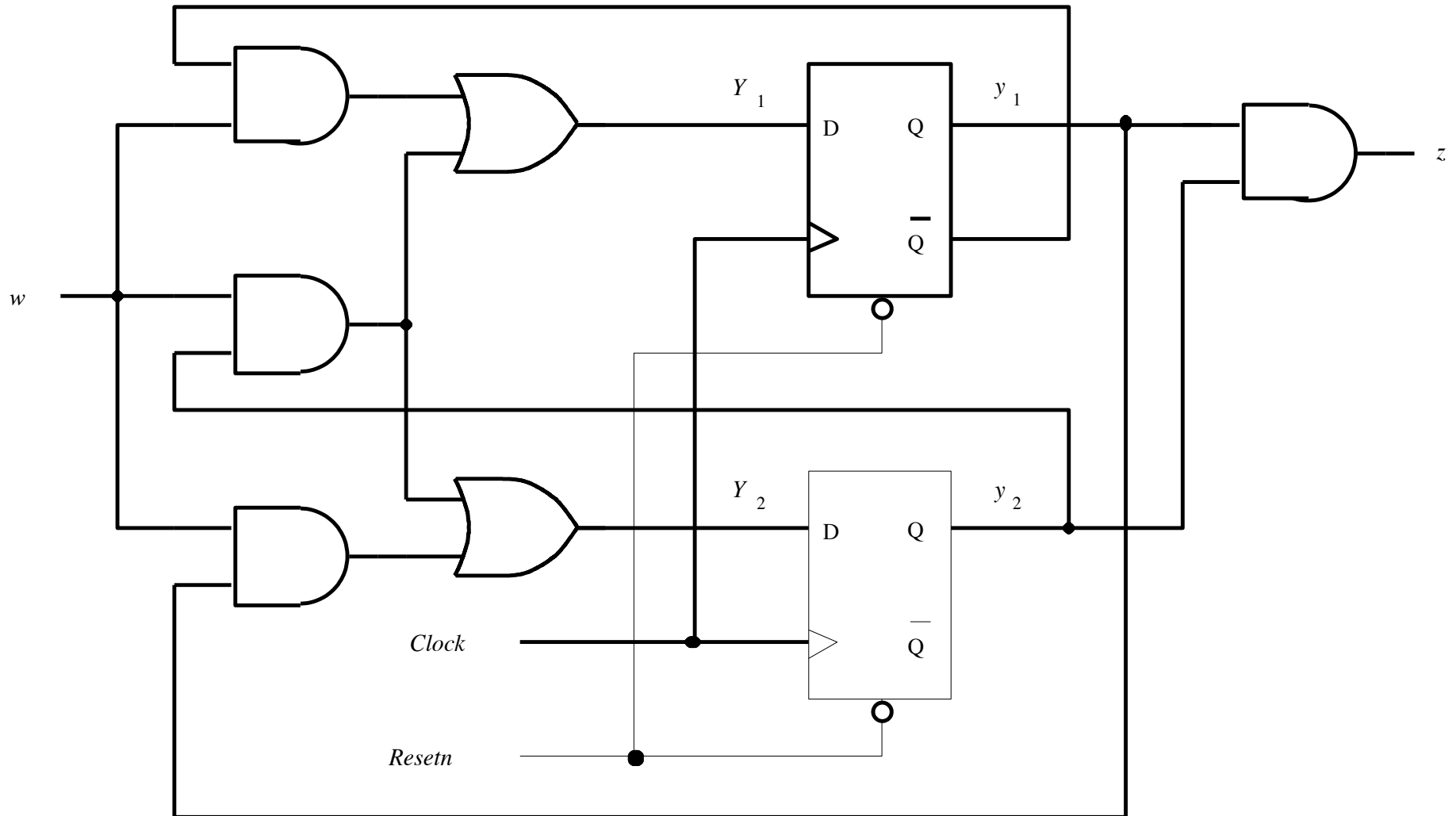

[Figure 6.75 from the textbook]

Where are the outputs?

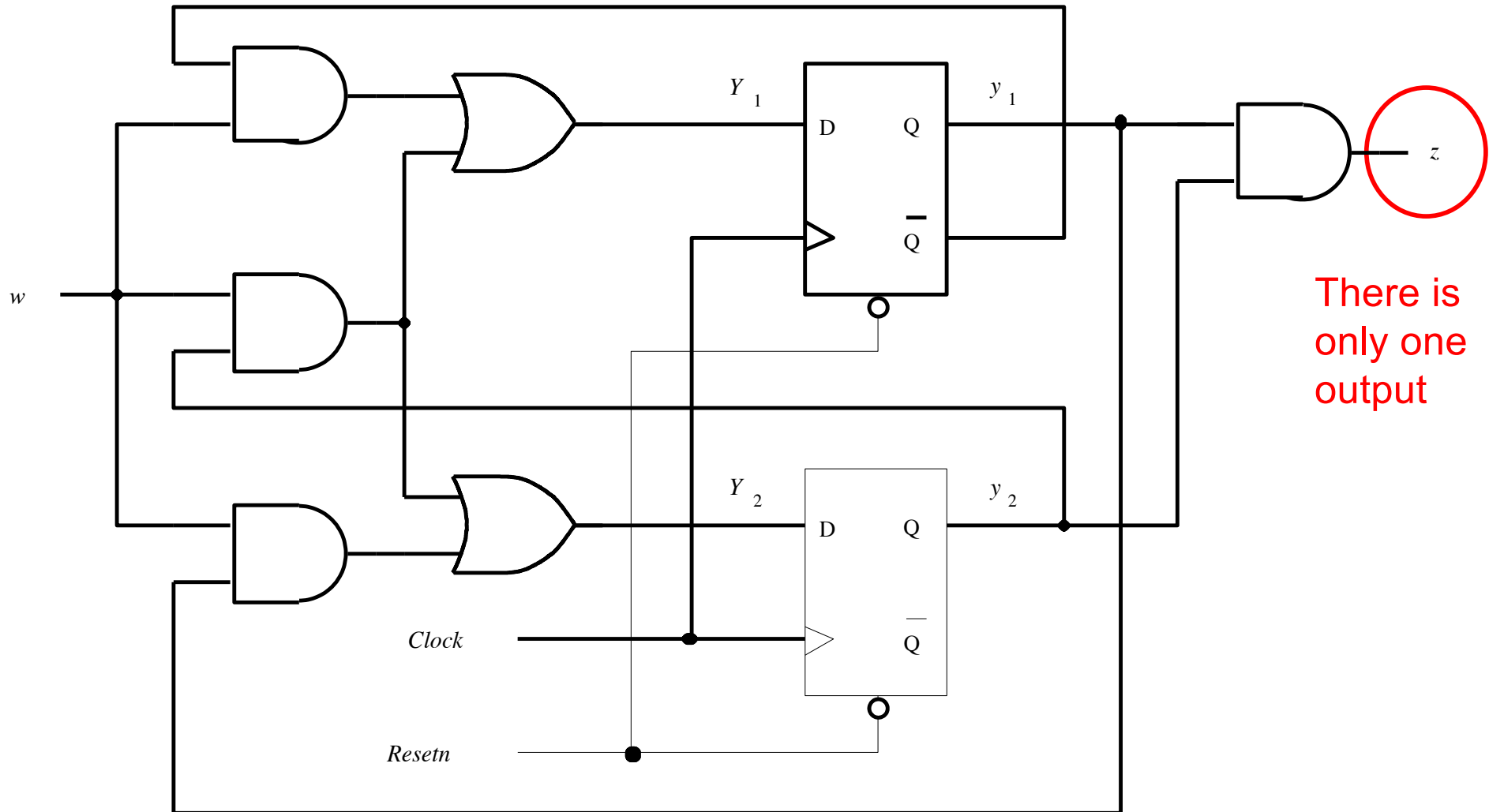

[Figure 6.75 from the textbook]

Where kind of machine is this? Moore or Mealy?

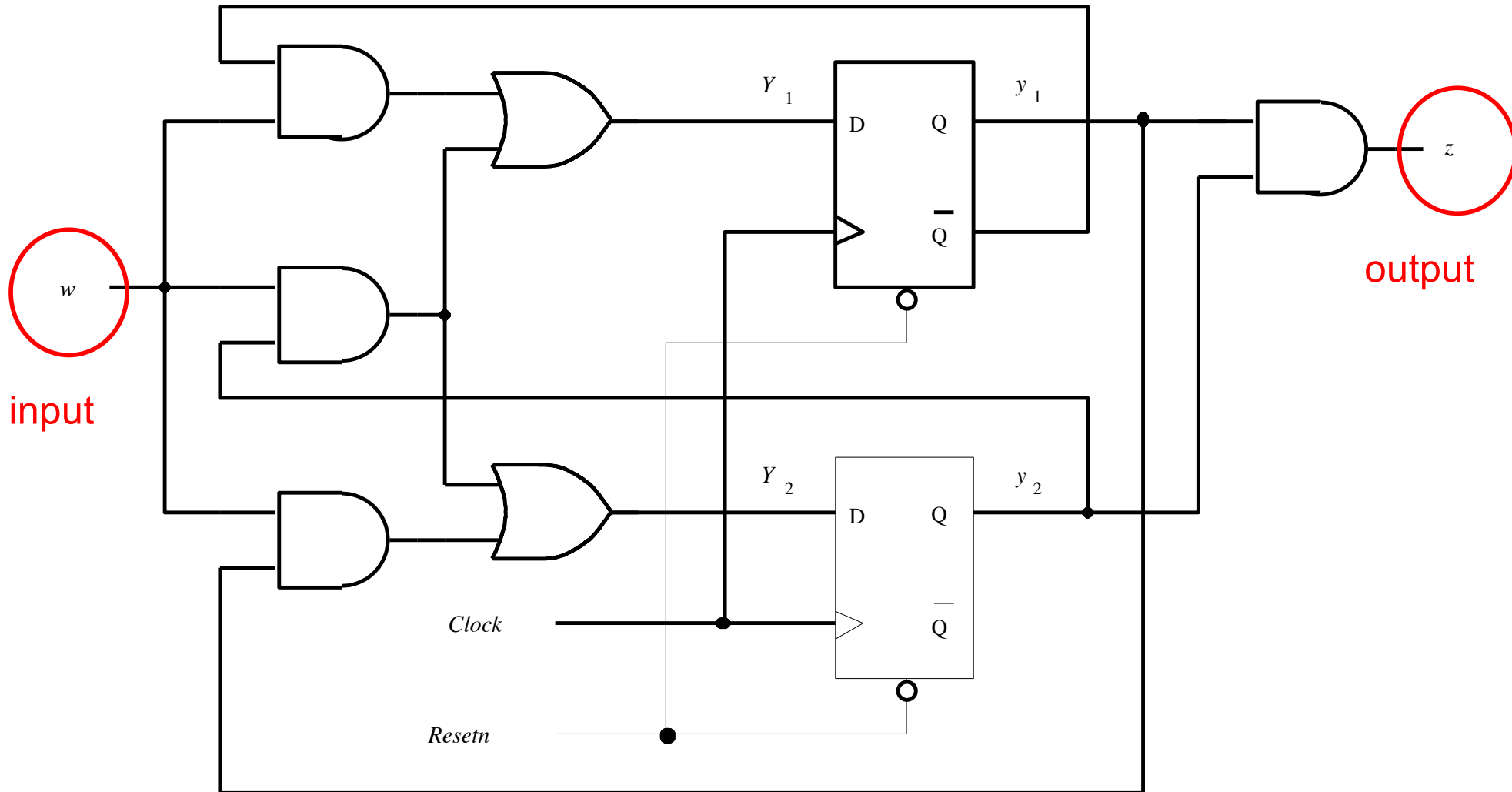

Moore: because the output does not depend directly on the primary input

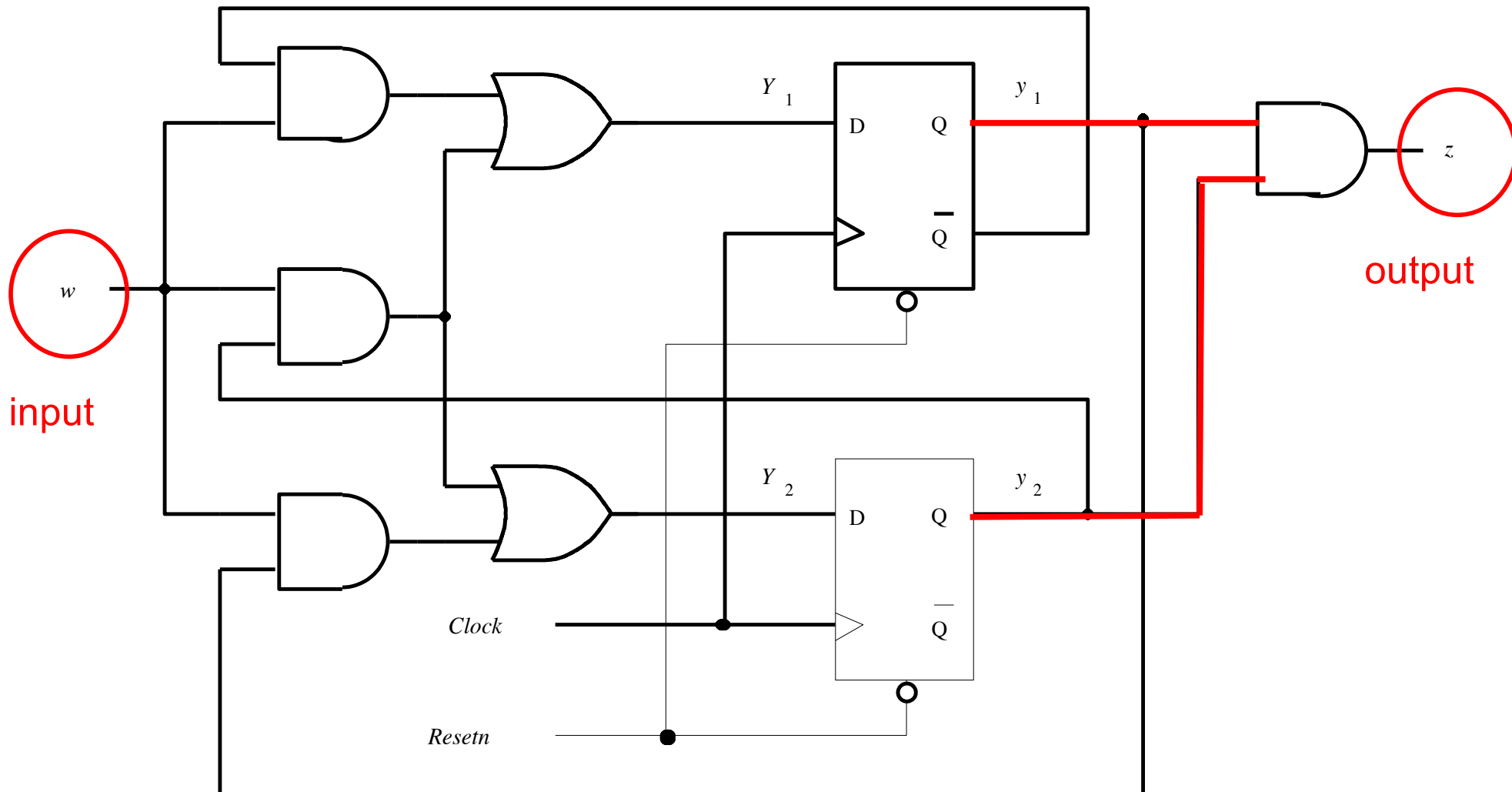

Where are the memory elements?

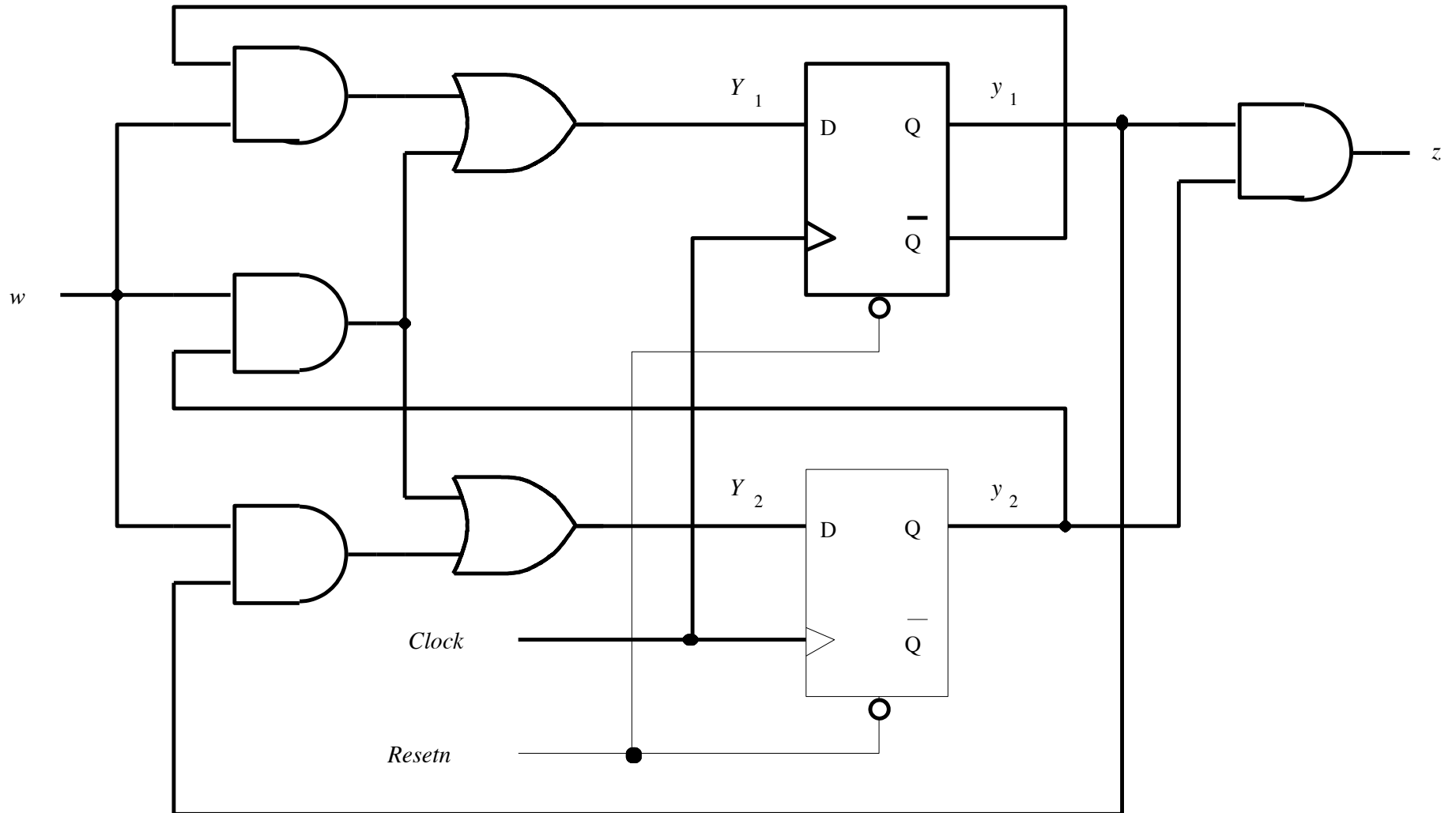

Where are the memory elements?

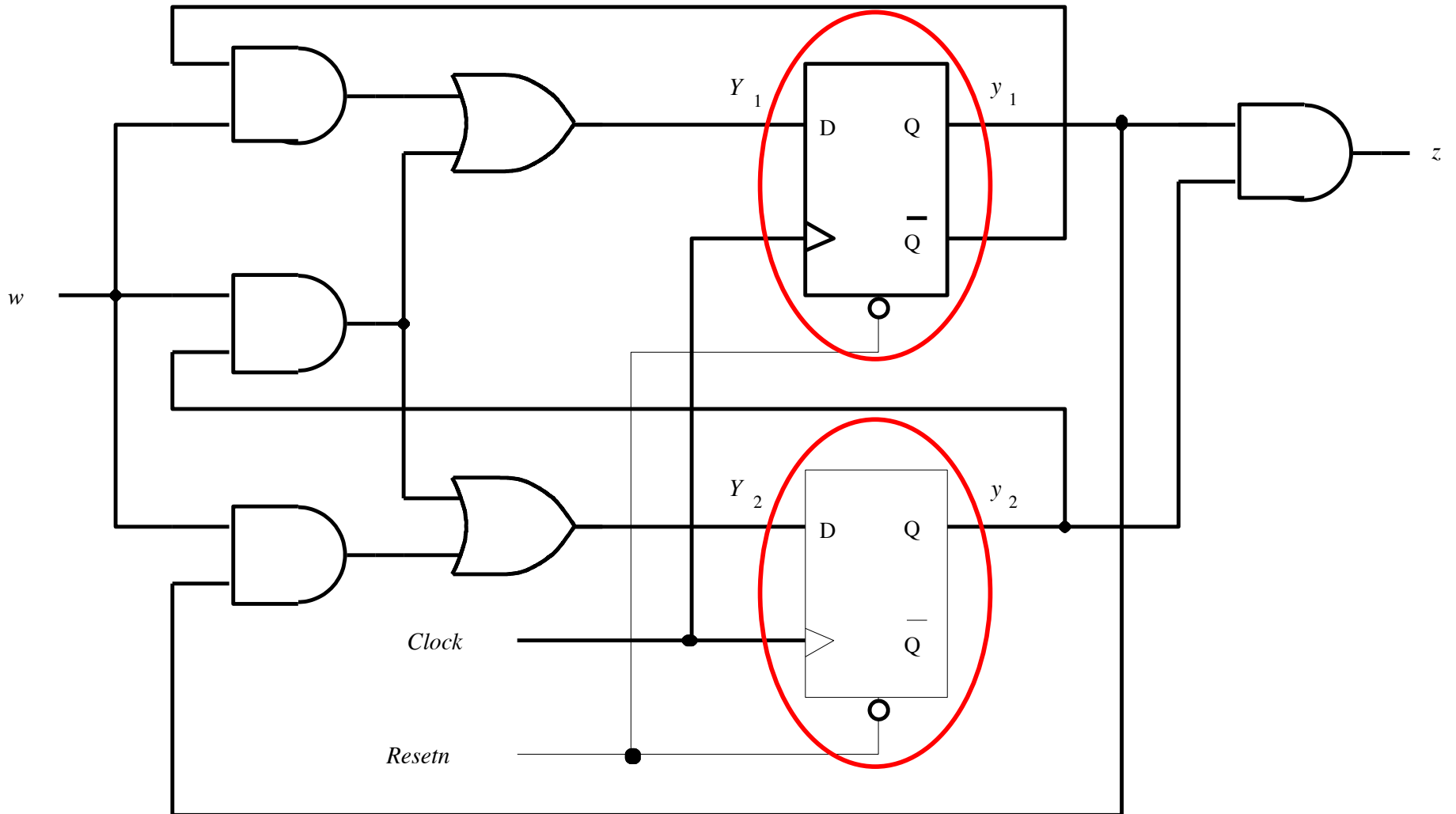

Where are the outputs of the flip-flops?

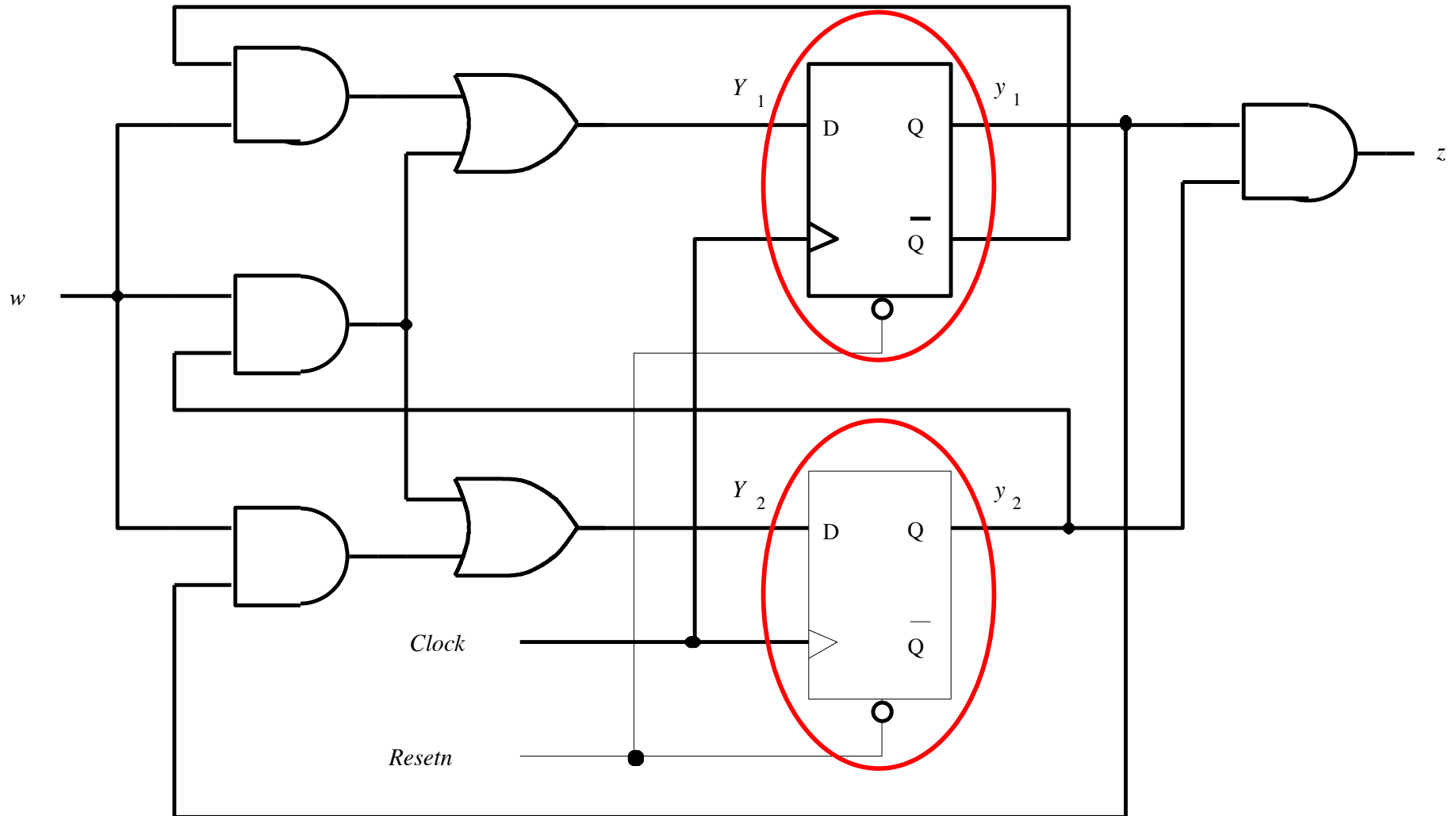

Where are the outputs of the flip-flops?

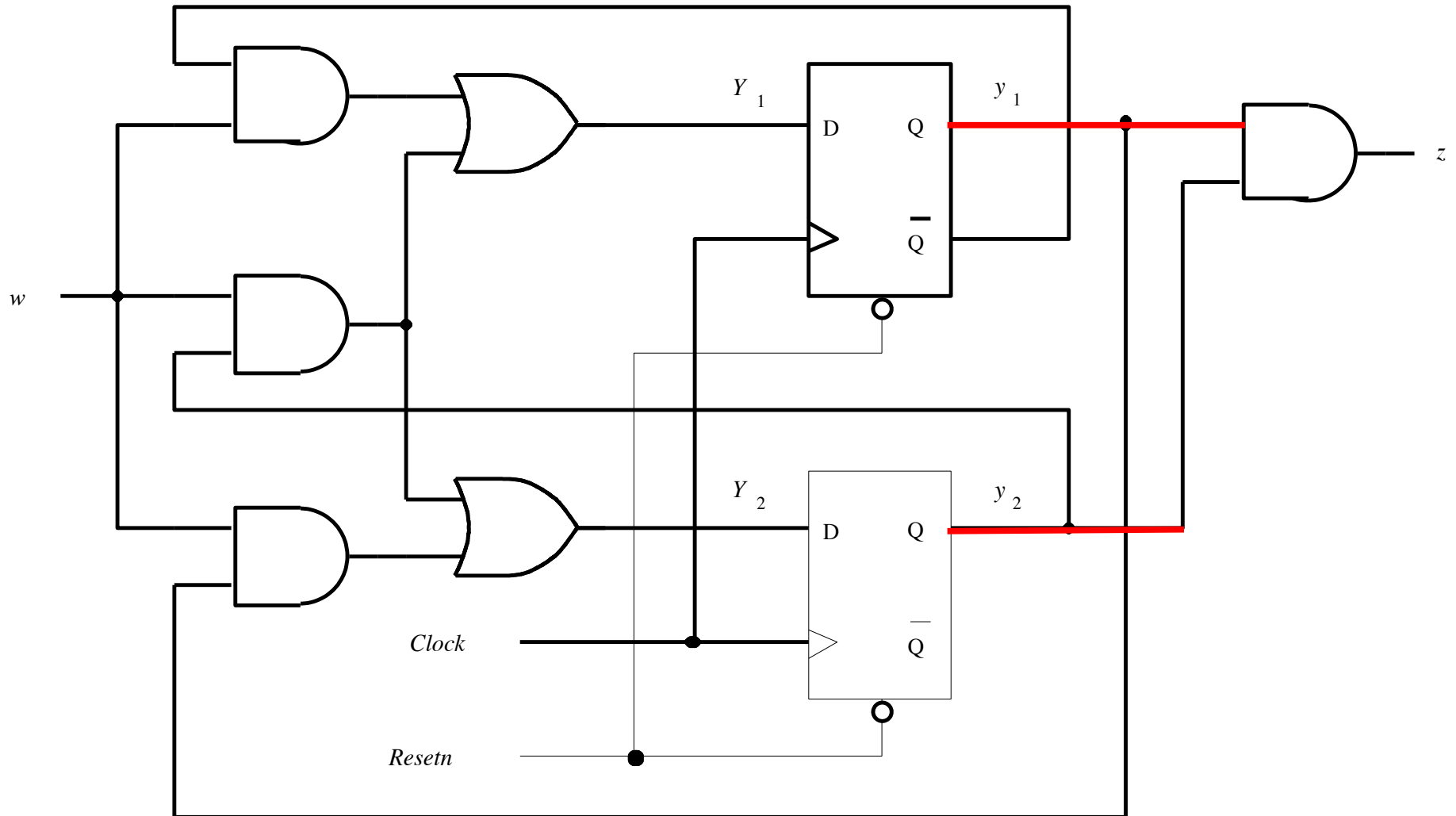

These are the present-state variables

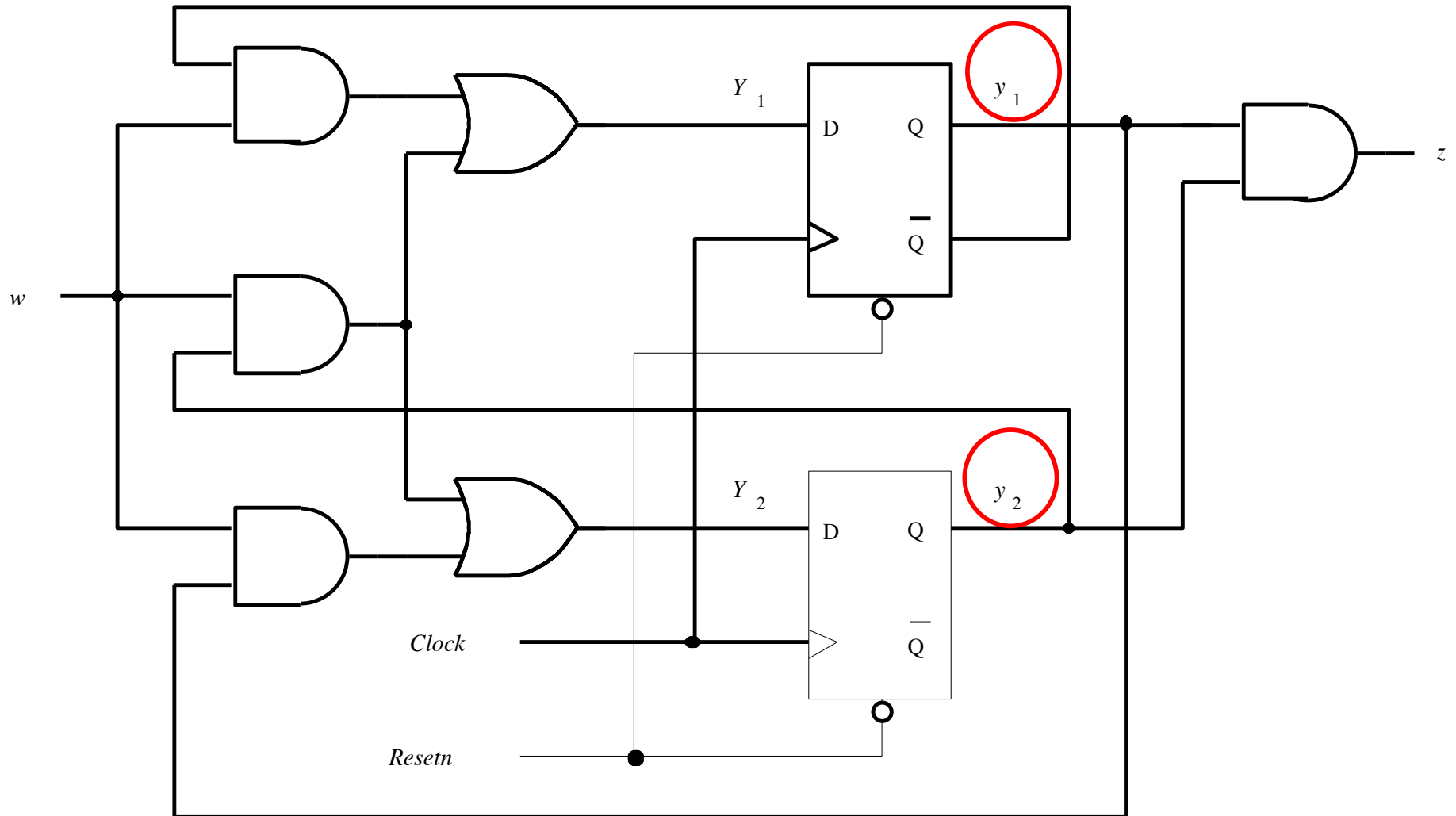

Where are the inputs of the flip-flops?

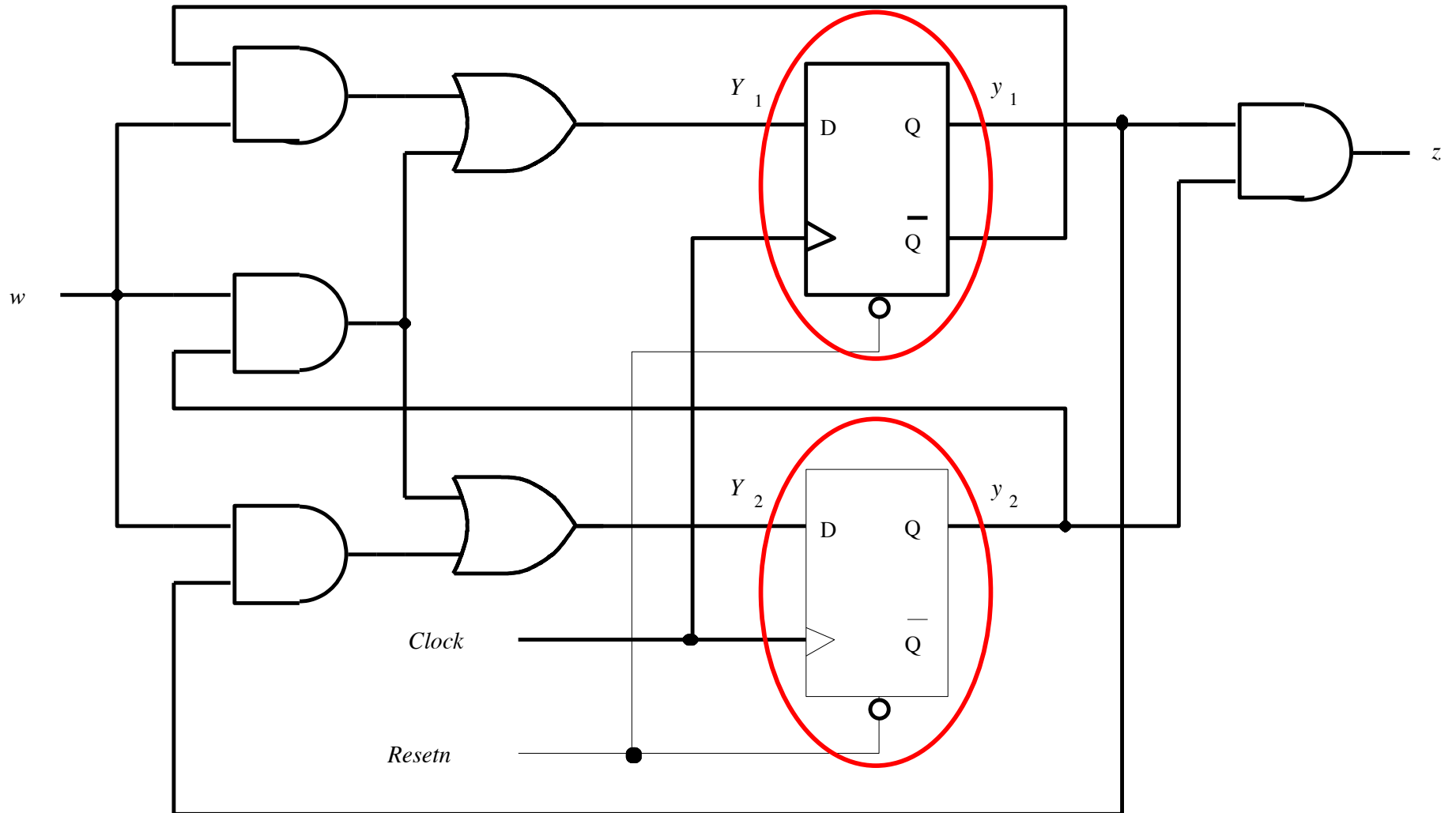

Where are the inputs of the flip-flops?

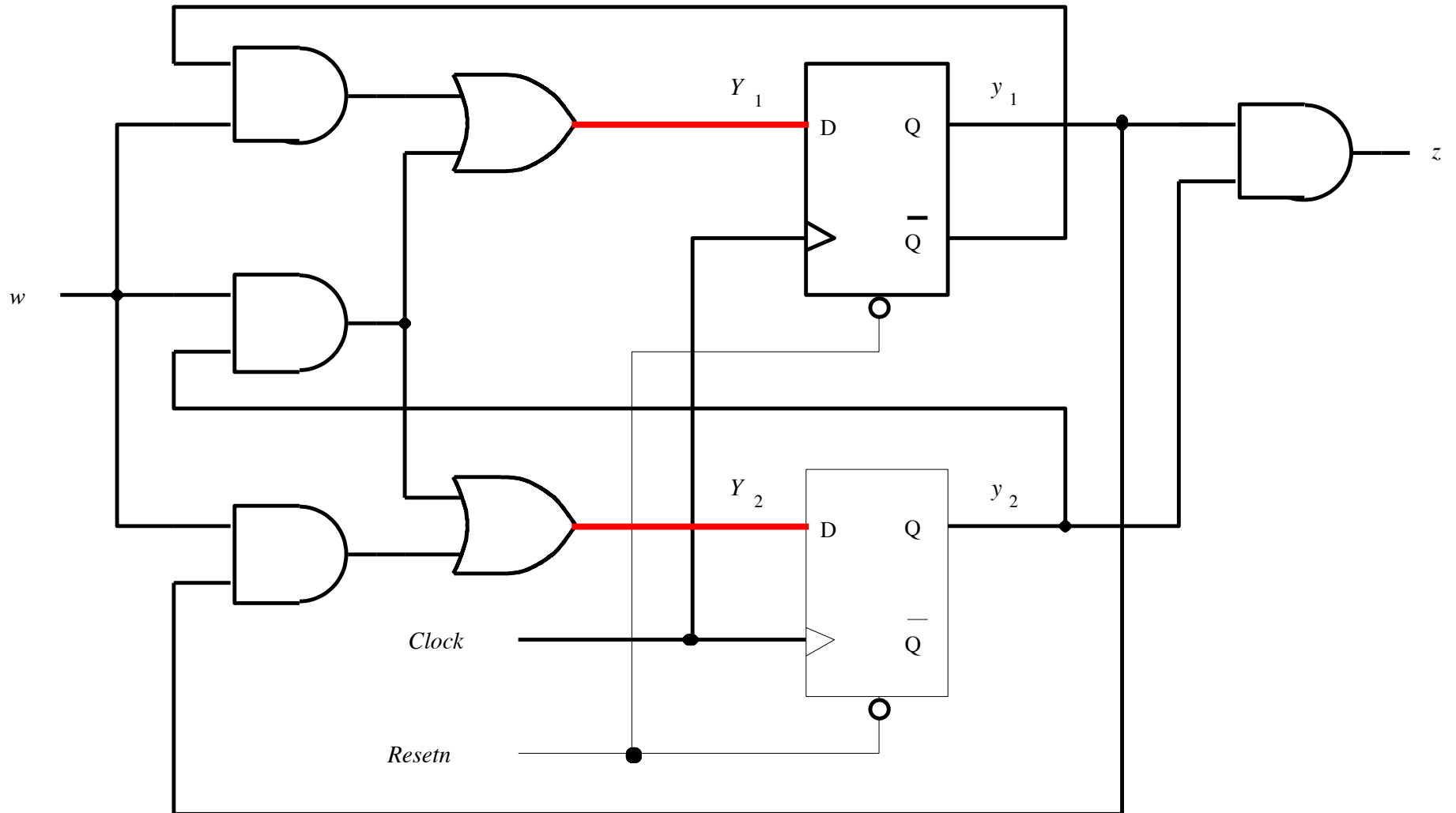

These are the next-state variables

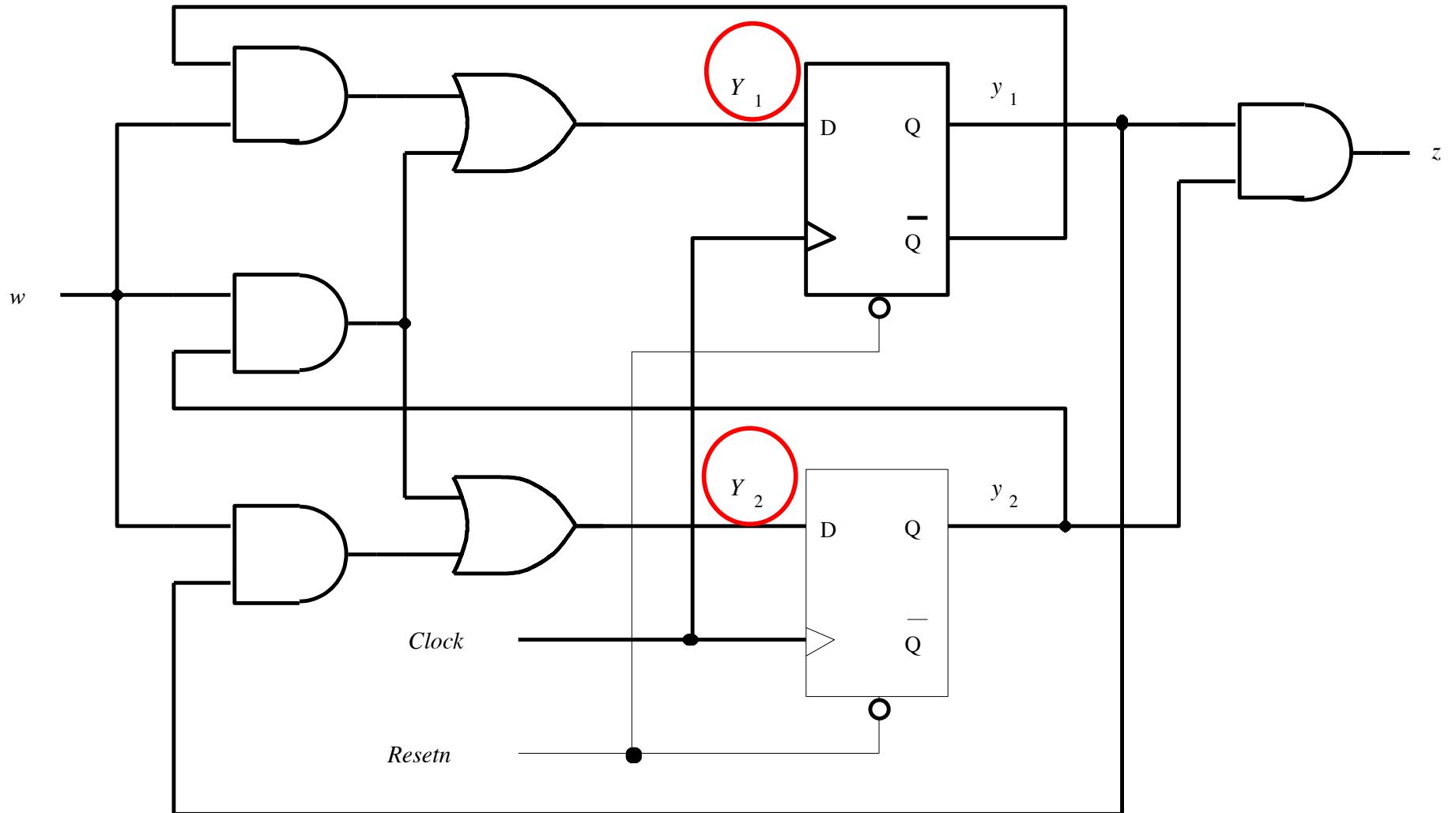

What are their logic expressions?

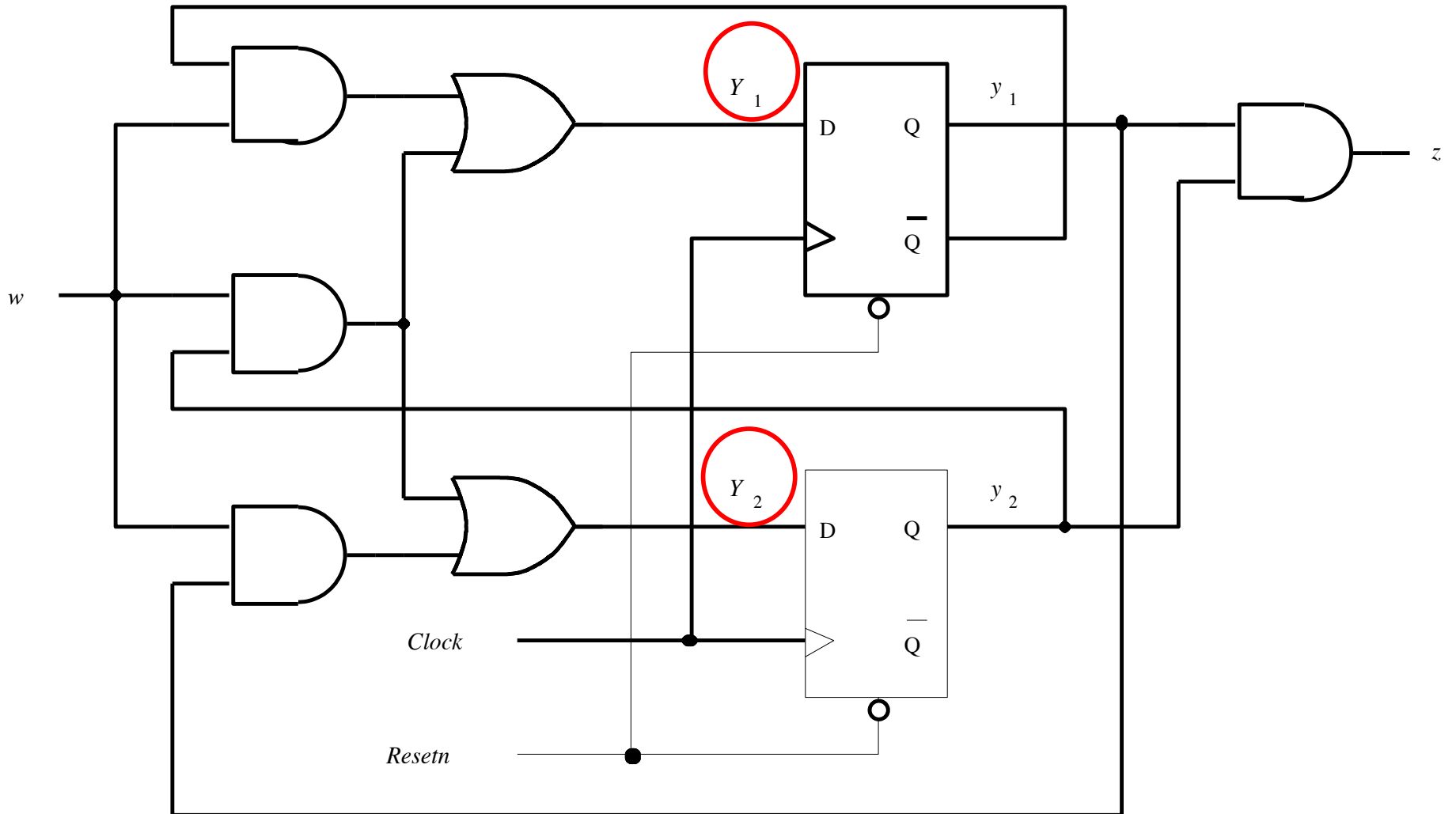

What are their logic expressions?

$$Y_1 = w\bar{y}_1 + wy_2$$

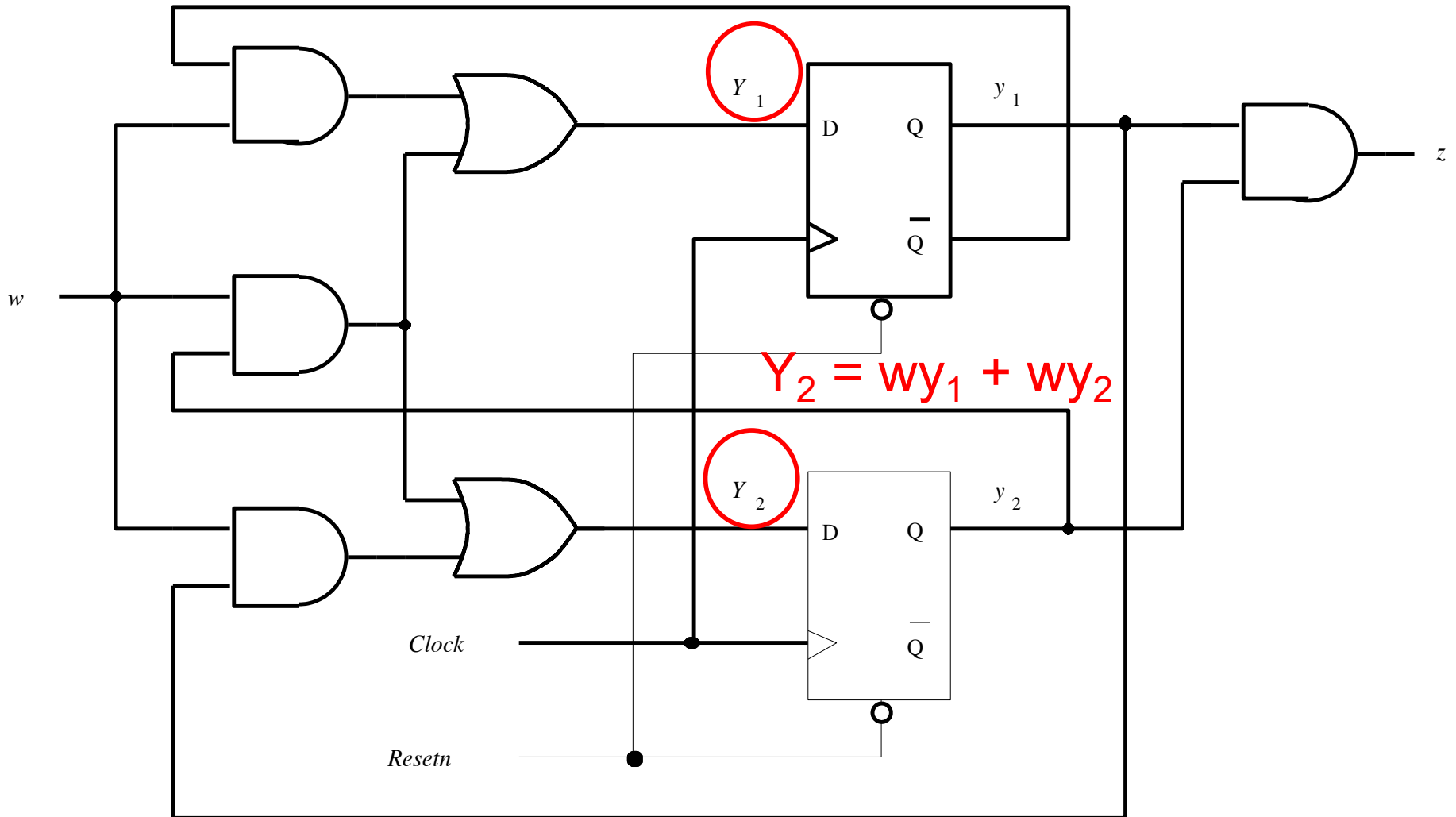

$$Y_2 = wy_1 + wy_2$$

Where is the output, again?

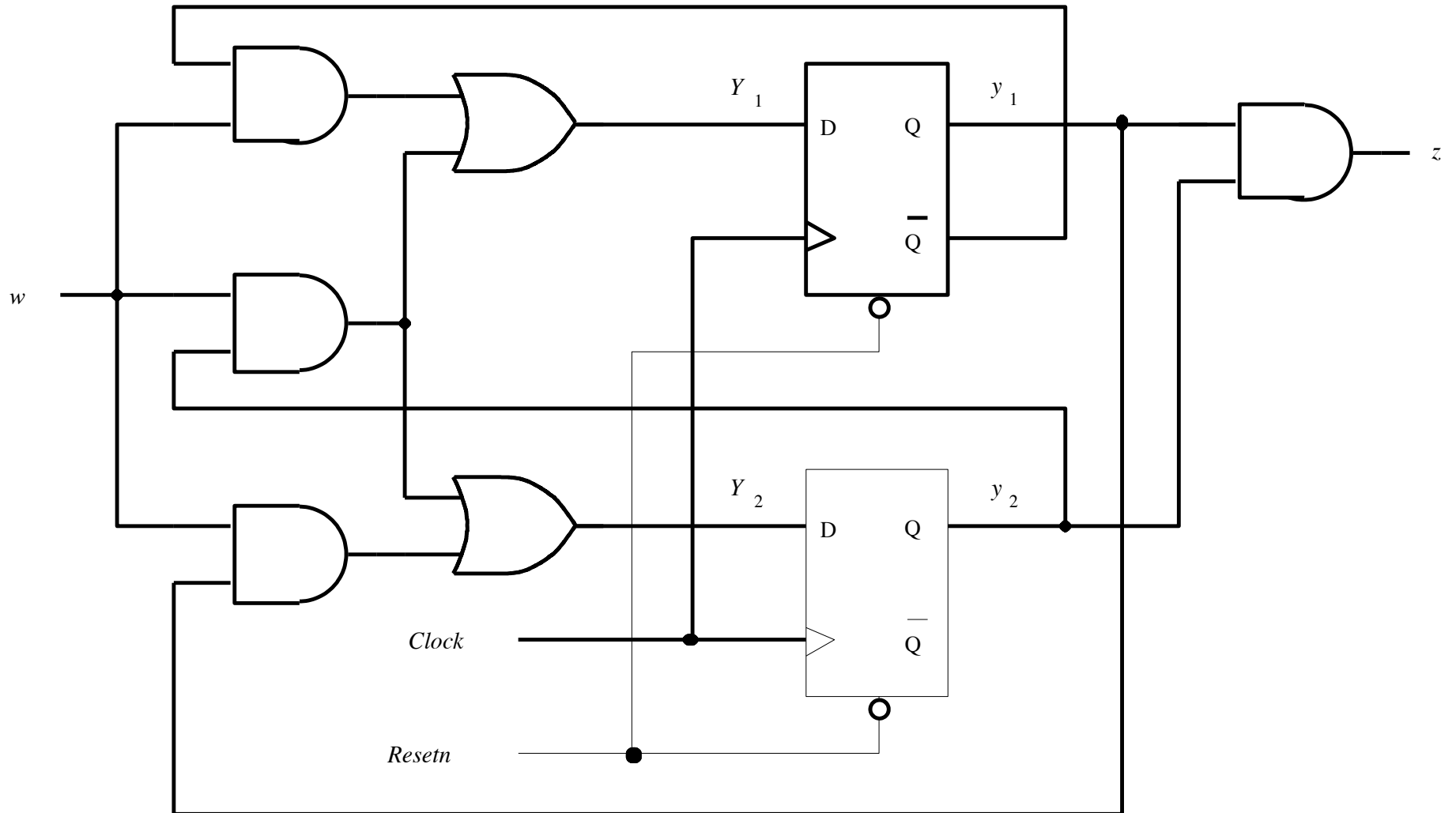

Where is the output, again?

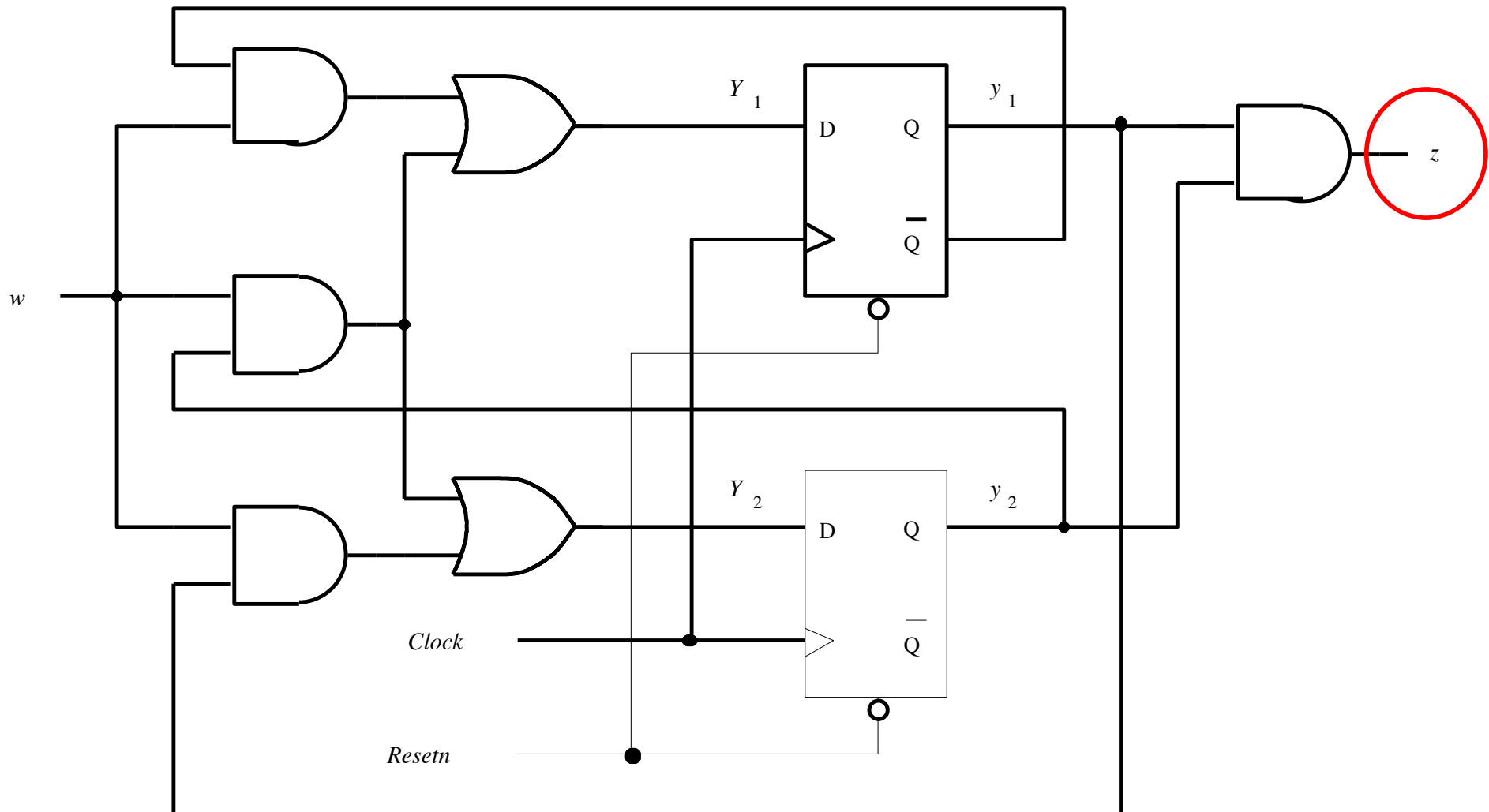

What is its logic expression?

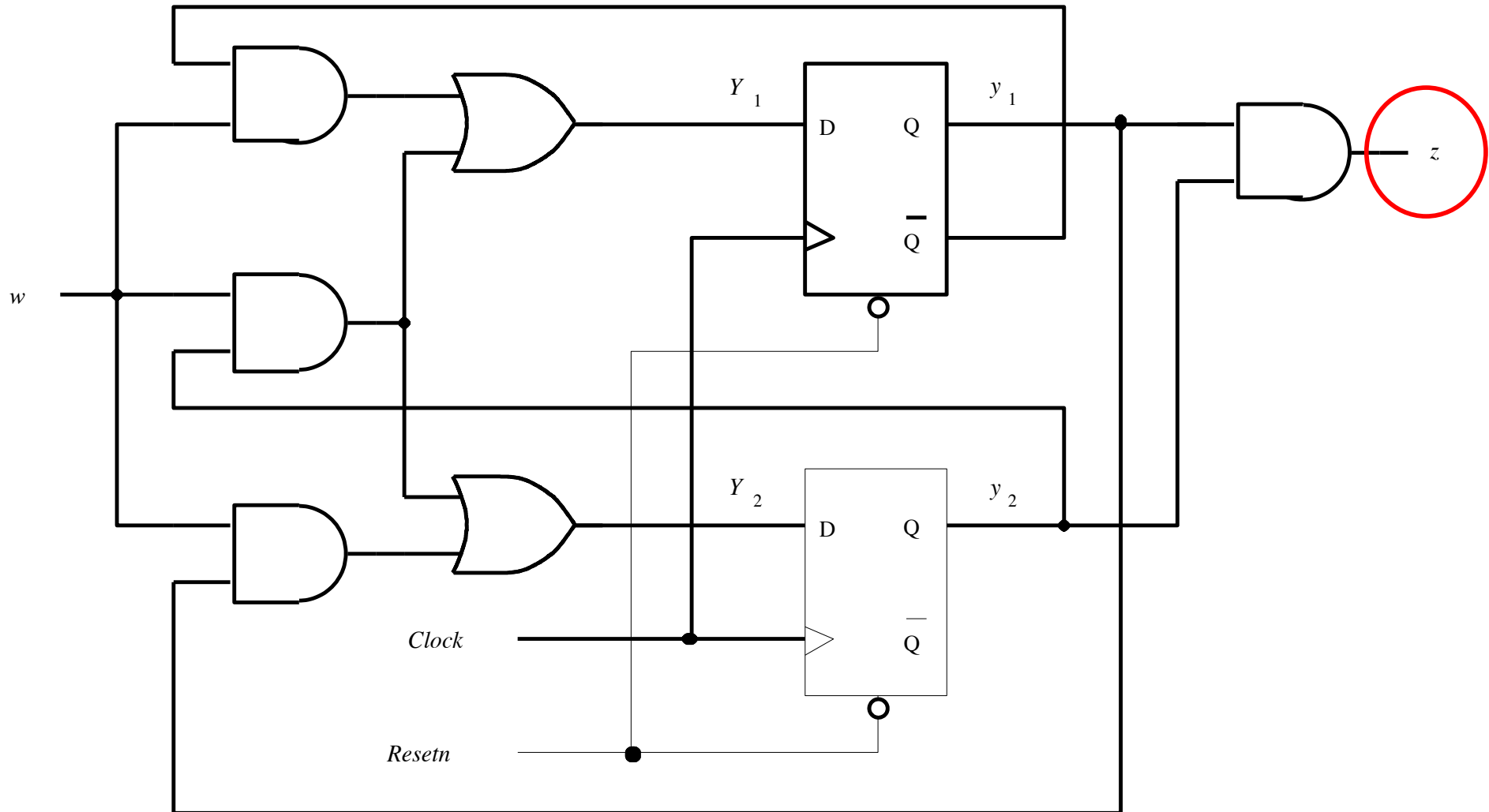

What is its logic expression?

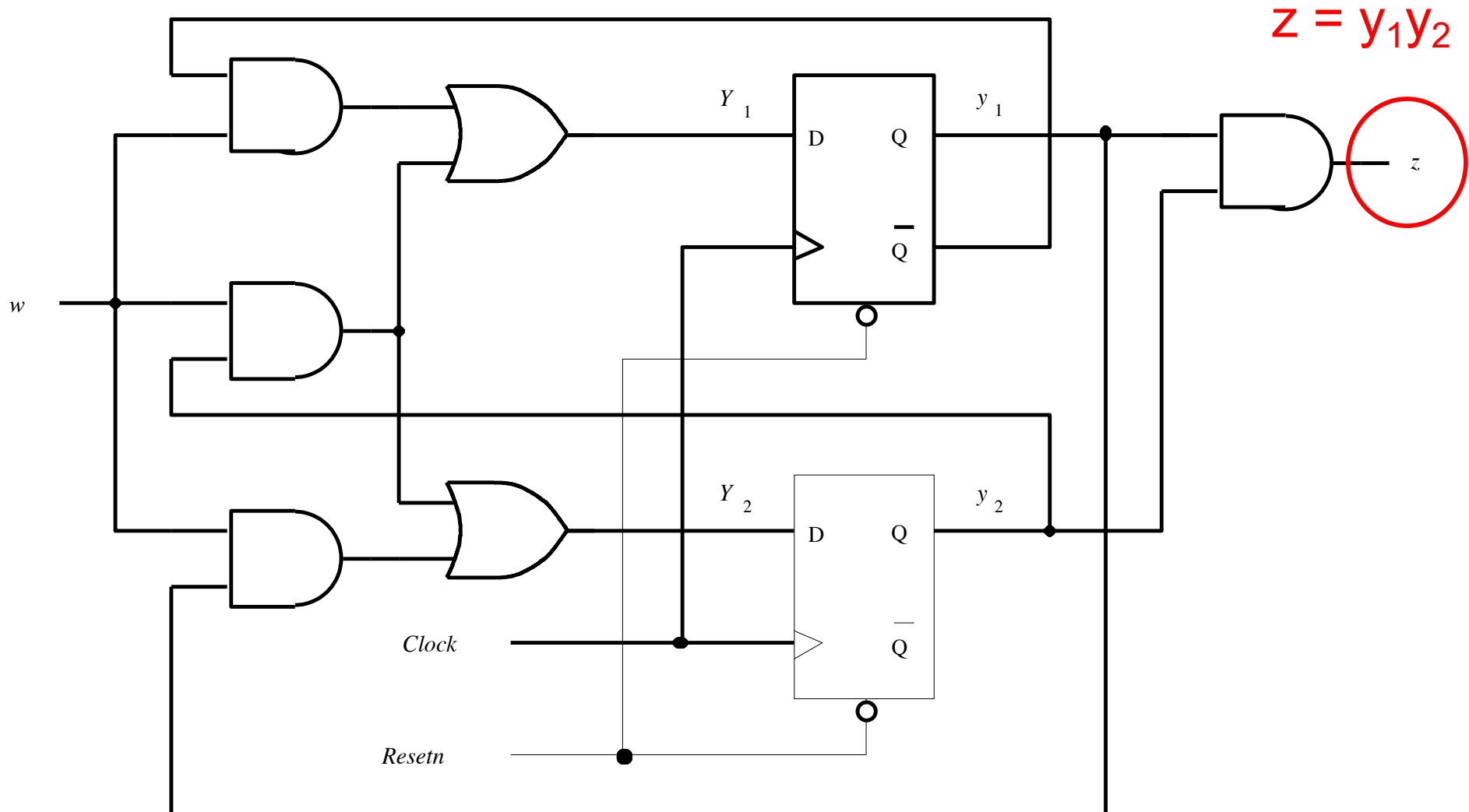

**This is what we have to work with now
(we don't need the circuit anymore)**

$$Y_1 = w\bar{y}_1 + wy_2$$

$$Y_2 = wy_1 + wy_2$$

$$z = y_1y_2$$

Let's derive the state-assigned table

$$Y_1 = w\bar{y}_1 + wy_2$$

$$Y_2 = wy_1 + wy_2$$

$$z = y_1y_2$$

Present state y_2y_1	Next State		Output z
	$w = 0$	$w = 1$	
	Y_2Y_1	Y_2Y_1	
00			
01			
10			
11			

Let's derive the state-assigned table

$$Y_1 = w\bar{y}_1 + wy_2$$

$$Y_2 = wy_1 + wy_2$$

$$z = y_1y_2$$

Present state y_2y_1	Next State		Output z
	$w = 0$	$w = 1$	
	Y_2Y_1	Y_2Y_1	
00			
01			
10			
11			

Let's derive the state-assigned table

$$Y_1 = w\bar{y}_1 + wy_2$$

$$Y_2 = wy_1 + wy_2$$

$$z = y_1y_2$$

Present state y_2y_1	Next State		Output z
	$w = 0$	$w = 1$	
	Y_2Y_1	Y_2Y_1	
00			0
01			0
10			0
11			1

Let's derive the state-assigned table

$$Y_1 = w\bar{y}_1 + wy_2$$

$$Y_2 = wy_1 + wy_2$$

$$z = y_1y_2$$

Present state y_2y_1	Next State		Output z
	$w = 0$	$w = 1$	
	Y_2Y_1	Y_2Y_1	
00			0
01			0
10			0
11			1

Let's derive the state-assigned table

$$Y_1 = w\bar{y}_1 + wy_2$$

$$Y_2 = wy_1 + wy_2$$

$$z = y_1y_2$$

Present state y_2y_1	Next State		Output z
	$w = 0$	$w = 1$	
	Y_2Y_1	Y_2Y_1	
00	0	1	0
01	0	0	0
10	0	1	0
11	0	1	1

Let's derive the state-assigned table

$$Y_1 = w\bar{y}_1 + wy_2$$

$$Y_2 = wy_1 + wy_2$$

$$z = y_1y_2$$

Present state y_2y_1	Next State		Output z
	$w = 0$	$w = 1$	
	Y_2Y_1	Y_2Y_1	
00	0	1	0
01	0	0	0
10	0	1	0
11	0	1	1

Let's derive the state-assigned table

$$Y_1 = w\bar{y}_1 + wy_2$$

$$Y_2 = wy_1 + wy_2$$

$$z = y_1y_2$$

Present state y_2y_1	Next State		Output z
	$w = 0$	$w = 1$	
	Y_2Y_1	Y_2Y_1	
00	00	01	0
01	00	10	0
10	00	11	0
11	00	11	1

We don't need the logic expressions anymore

$$Y_1 = w\bar{y}_1 + wy_2$$

$$Y_2 = wy_1 + wy_2$$

$$z = y_1y_2$$

Present state y_2y_1	Next State		Output z
	$w = 0$	$w = 1$	
	Y_2Y_1	Y_2Y_1	
00	00	01	0
01	00	10	0
10	00	11	0
11	00	11	1

We don't need the logic expressions anymore

Present state y_2y_1	Next State		Output z
	$w = 0$	$w = 1$	
	Y_2Y_1	Y_2Y_1	
00	00	01	0
01	00	10	0
10	00	11	0
11	00	11	1

Let's derive the state table

Present state	Next state		Output z
	w = 0	w = 1	

State table

Present state y_2y_1	Next State		Output z
	w = 0	w = 1	
	Y_2Y_1	Y_2Y_1	
00	00	01	0
01	00	10	0
10	00	11	0
11	00	11	1

State-assigned table

Let's derive the state table

Present state	Next state		Output z
	w = 0	w = 1	

State table

Present state y_2y_1	Next State		Output z
	w = 0	w = 1	
	Y_2Y_1	Y_2Y_1	
00	00	01	0
01	00	10	0
10	00	11	0
11	00	11	1

State-assigned table

Let's derive the state table

Present state	Next state		Output z
	w = 0	w = 1	
A			
B			
C			
D			

State table

Present state y_2y_1	Next State		Output z
	w = 0 Y_2Y_1	w = 1 Y_2Y_1	
00	00	01	0
01	00	10	0
10	00	11	0
11	00	11	1

State-assigned table

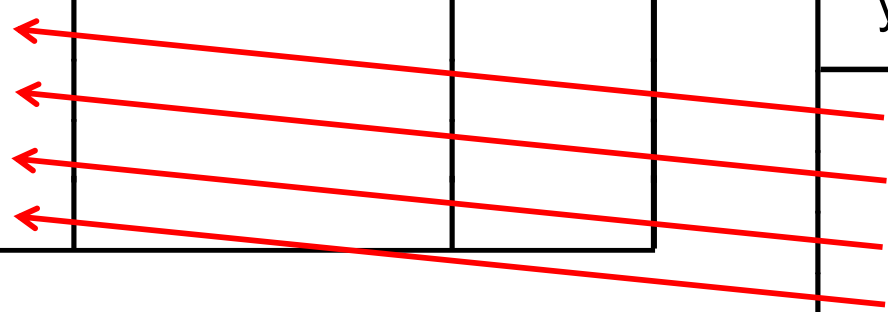

Let's derive the state table

Present state	Next state		Output z
	w = 0	w = 1	
A			
B			
C			
D			

State table

Present state y_2y_1	Next State		Output z
	w = 0 Y_2Y_1	w = 1 Y_2Y_1	
00	00	01	0
01	00	10	0
10	00	11	0
11	00	11	1

State-assigned table

Let's derive the state table

Present state	Next state		Output z
	w = 0	w = 1	
A	A		
B	A		
C	A		
D	A		

State table

Present state y_2y_1	Next State		Output z
	w = 0 Y_2Y_1	w = 1 Y_2Y_1	
00	00	01	0
01	00	10	0
10	00	11	0
11	00	11	1

State-assigned table

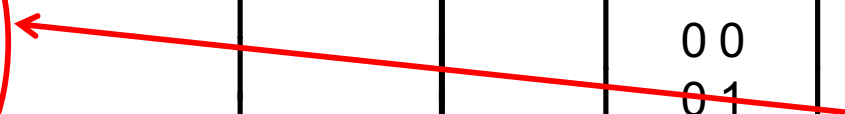

Let's derive the state table

Present state	Next state		Output z
	w = 0	w = 1	
A	A		
B	A		
C	A		
D	A		

State table

Present state y_2y_1	Next State		Output z
	w = 0 Y_2Y_1	w = 1 Y_2Y_1	
00	00	01	0
01	00	10	0
10	00	11	0
11	00	11	1

State-assigned table

Let's derive the state table

Present state	Next state		Output z
	w = 0	w = 1	
A	A	B	
B	A	C	
C	A	D	
D	A	D	

State table

Present state y_2y_1	Next State		Output z
	w = 0 Y_2Y_1	w = 1 Y_2Y_1	
00	00	01	0
01	00	10	0
10	00	11	0
11	00	11	1

State-assigned table

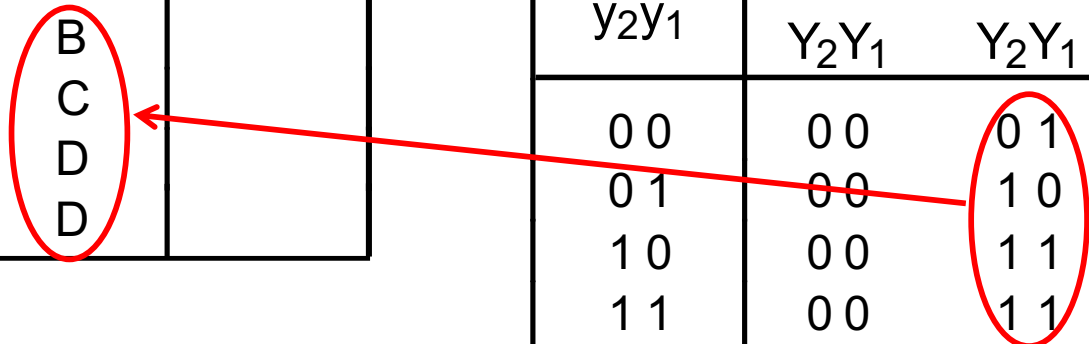

Let's derive the state table

Present state	Next state		Output z
	w = 0	w = 1	
A	A	B	
B	A	C	
C	A	D	
D	A	D	

State table

Present state y_2y_1	Next State		Output z
	w = 0	w = 1	
	Y_2Y_1	Y_2Y_1	
00	00	01	0
01	00	10	0
10	00	11	0
11	00	11	1

State-assigned table

Let's derive the state table

Present state	Next state		Output z
	w = 0	w = 1	
A	A	B	
B	A	C	
C	A	D	
D	A	D	

State table

Present state y_2y_1	Next State		Output z
	w = 0	w = 1	
	Y_2Y_1	Y_2Y_1	
00	00	01	0
01	00	10	0
10	00	11	0
11	00	11	1

State-assigned table

The output is the same in both tables

The two tables for the initial circuit

Present state	Next state		Output z
	w = 0	w = 1	
A	A	B	0
B	A	C	0
C	A	D	0
D	A	D	1

State table

Present state y_2y_1	Next State		Output z
	w = 0 Y_2Y_1	w = 1 Y_2Y_1	
00	00	01	0
01	00	10	0
10	00	11	0
11	00	11	1

State-assigned table

We don't need the state-assigned table anymore

Present state	Next state		Output z
	w = 0	w = 1	
A	A	B	0
B	A	C	0
C	A	D	0
D	A	D	1

State table

Present state y_2y_1	Next State		Output z
	w = 0 Y_2Y_1	w = 1 Y_2Y_1	
00	00	01	0
01	00	10	0
10	00	11	0
11	00	11	1

State-assigned table

We don't need the state-assigned table anymore

Present state	Next state		Output z
	w = 0	w = 1	
A	A	B	0
B	A	C	0
C	A	D	0
D	A	D	1

State table

Let's Draw the State Diagram

Present state	Next state		Output z
	w = 0	w = 1	
A	A	B	0
B	A	C	0
C	A	D	0
D	A	D	1

Let's Draw the State Diagram

Present state	Next state		Output z
	w = 0	w = 1	
A	A	B	0
B	A	C	0
C	A	D	0
D	A	D	1

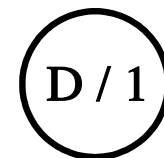
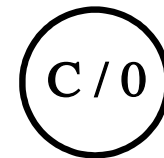
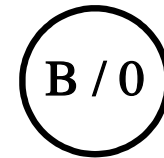
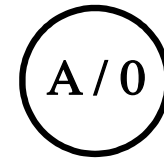

Because this is a Moore machine
the output is tied to the state

Let's Draw the State Diagram

Present state	Next state		Output z
	w = 0	w = 1	
A	A	B	0
B	A	C	0
C	A	D	0
D	A	D	1

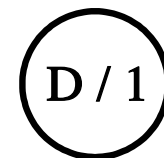
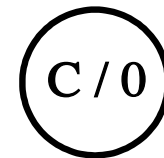
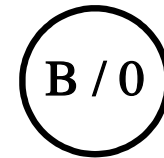
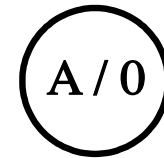

All transitions when the input w is equal to 1

Let's Draw the State Diagram

Present state	Next state		Output z
	w = 0	w = 1	
A	A	B	0
B	A	C	0
C	A	D	0
D	A	D	1

All transitions when the input w is equal to 1

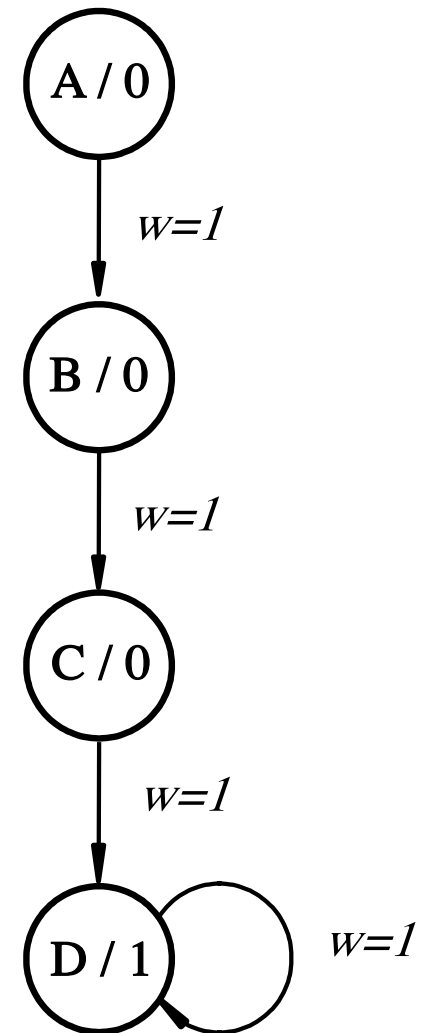

Let's Draw the State Diagram

Present state	Next state		Output z
	w = 0	w = 1	
A	A	B	0
B	A	C	0
C	A	D	0
D	A	D	1

All transitions when the input w is equal to 0

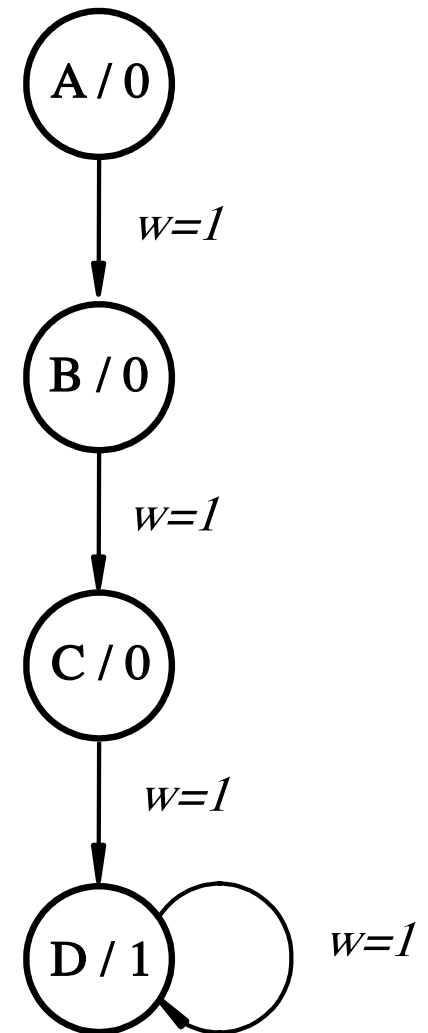

Let's Draw the State Diagram

Present state	Next state		Output z
	w = 0	w = 1	
A	A	B	0
B	A	C	0
C	A	D	0
D	A	D	1

All transitions when the input w is equal to 0

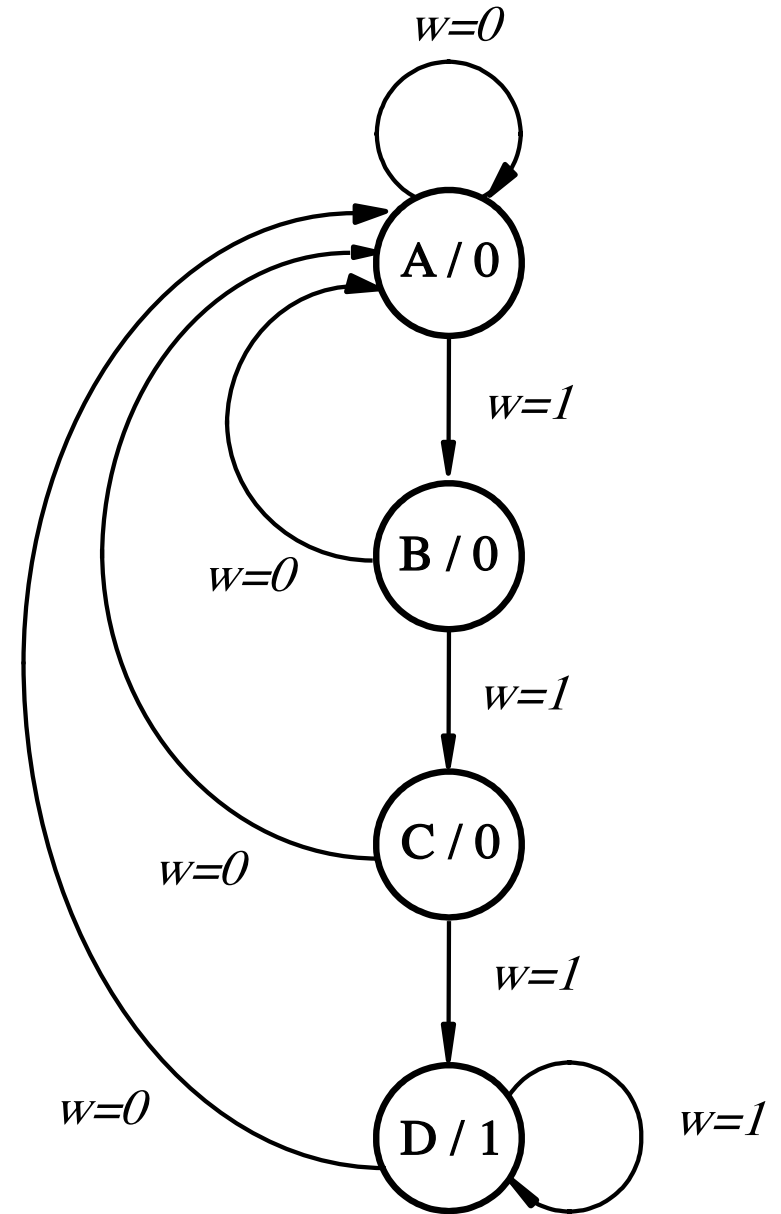

We are done!

Present state	Next state		Output z
	w = 0	w = 1	
A	A	B	0
B	A	C	0
C	A	D	0
D	A	D	1

State table

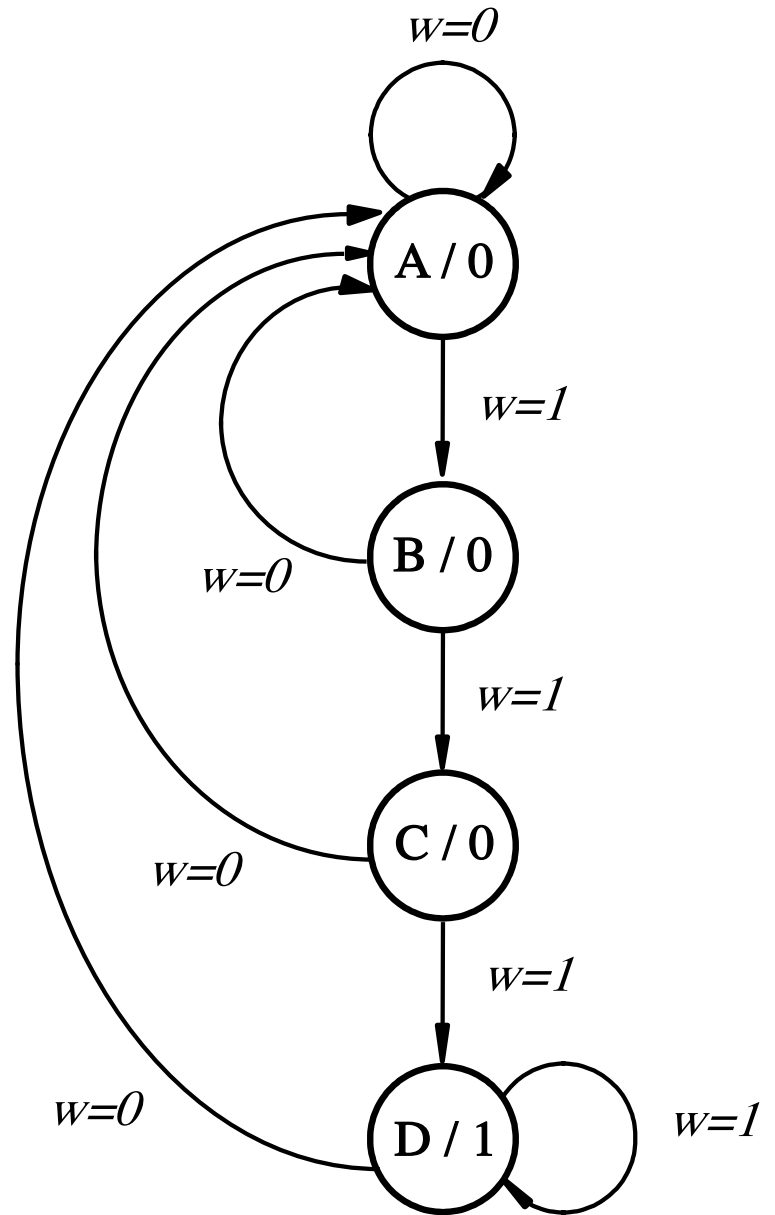

State diagram

Almost done. What does this FSM do?

Present state	Next state		Output z
	$w = 0$	$w = 1$	
A	A	B	0
B	A	C	0
C	A	D	0
D	A	D	1

State table

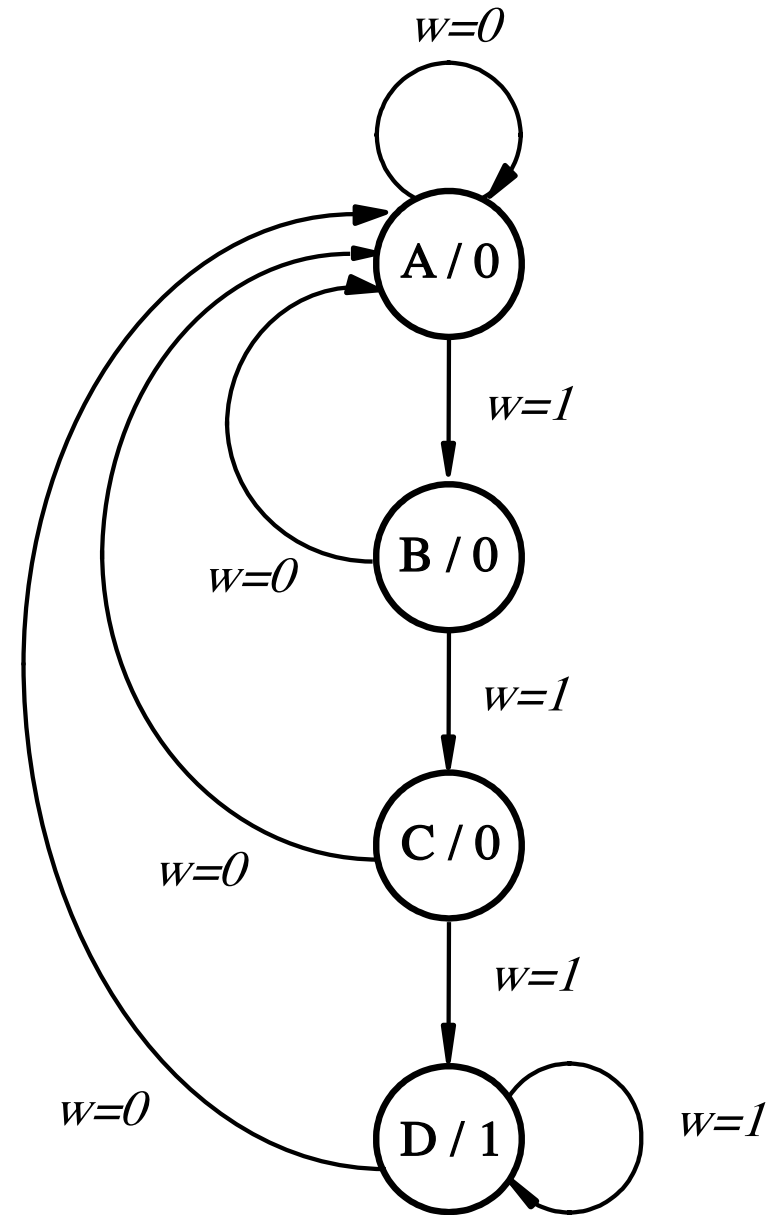

State diagram

Almost done. What does this FSM do?

It sets the output z to 1 when three consecutive 1's occur on the input w . In other words, it is a sequence detector for the input pattern 111.

Present state	Next state		Output z
	$w = 0$	$w = 1$	
A	A	B	0
B	A	C	0
C	A	D	0
D	A	D	1

State table

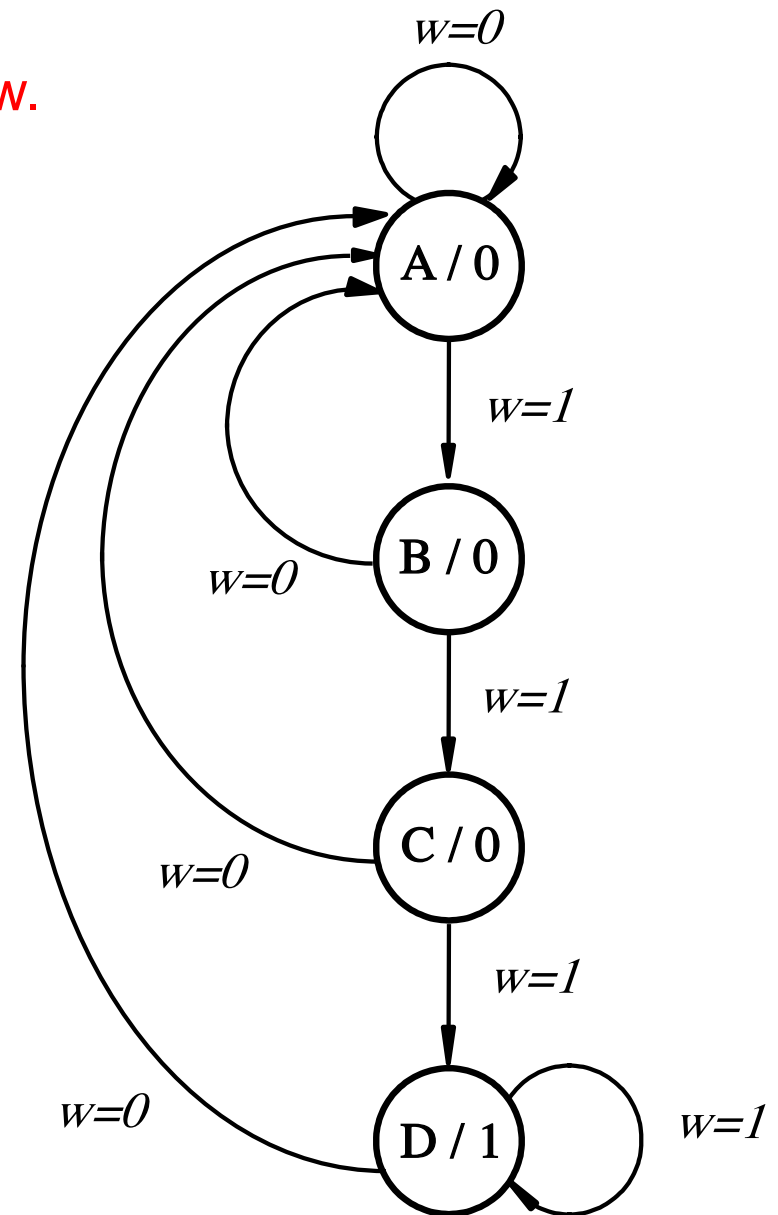

State diagram

Another Example (with JK flip-flops)

What does this circuit do?

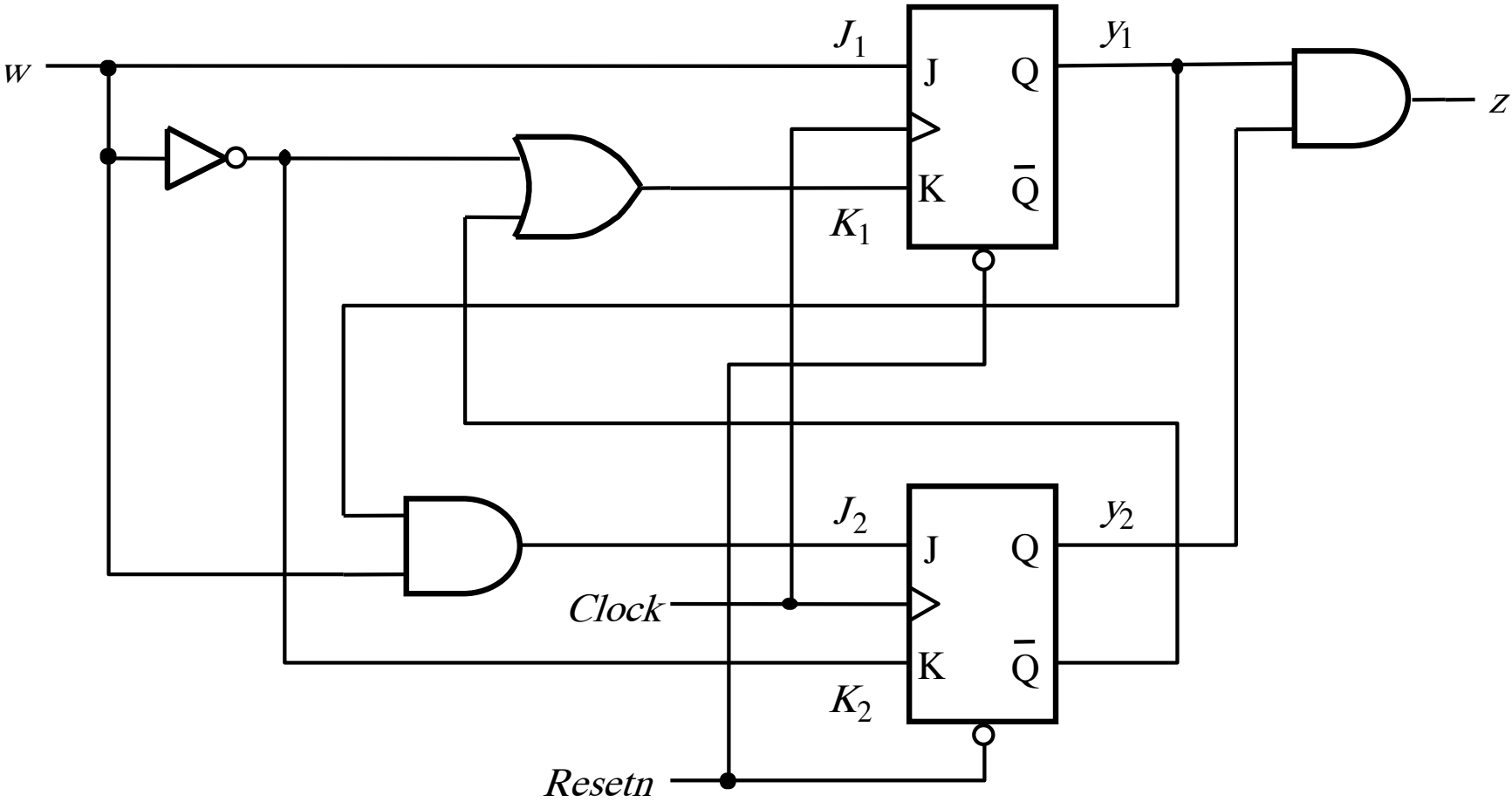

[Figure 6.77 from the textbook]

Approach

- **Find the flip-flops**
- **Outputs of the flip-flops = present state variables**
- **Inputs of the flip-flops determine the next state variables**
- **Determine the logical expressions for the outputs**
- **Given this info it is easy to do the state-assigned table**
- **Next do the state table**
- **Finally, draw the state diagram.**

Where are the inputs and outputs?

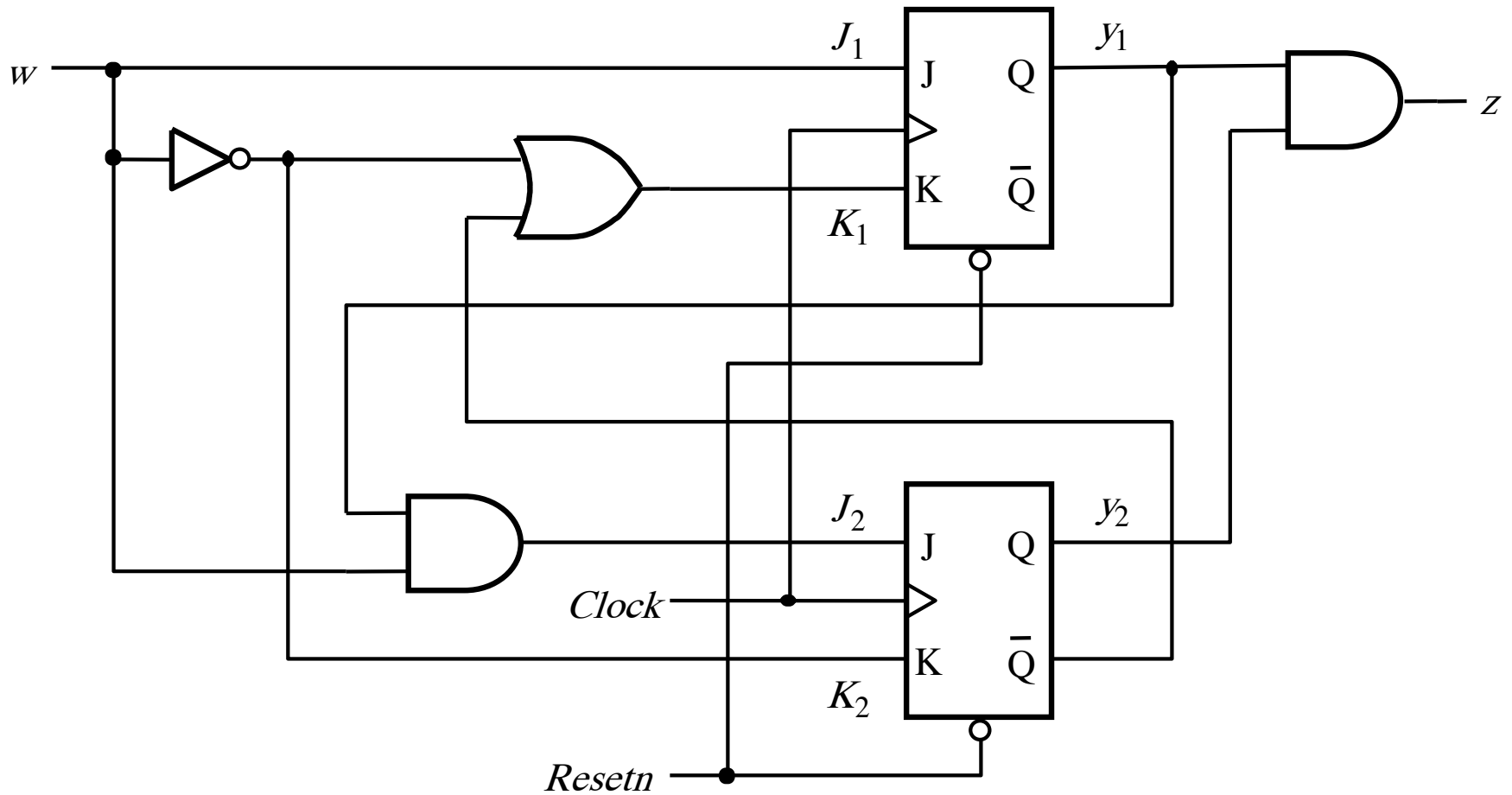

[Figure 6.77 from the textbook]

Where are the inputs and outputs?

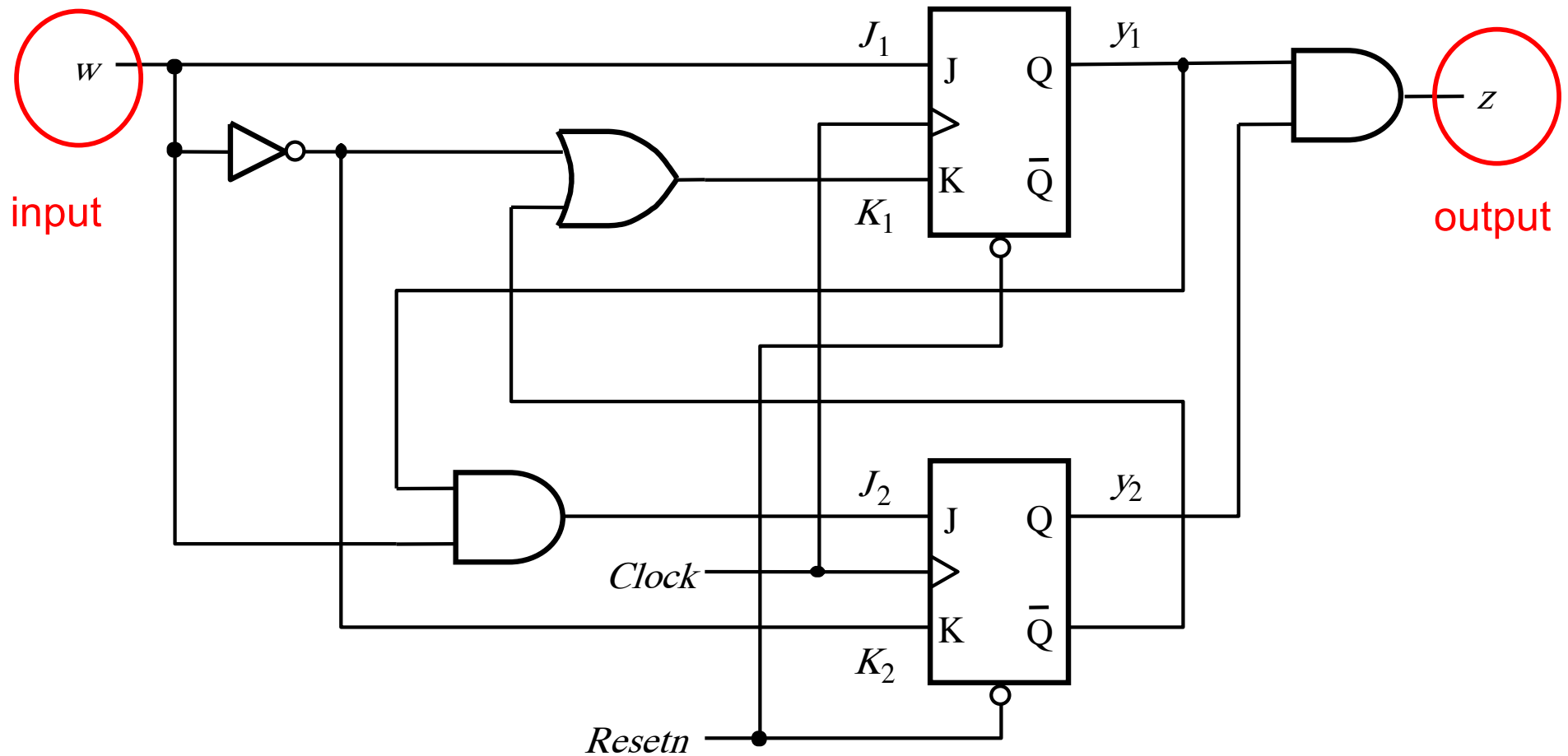

What kind of machine is this?

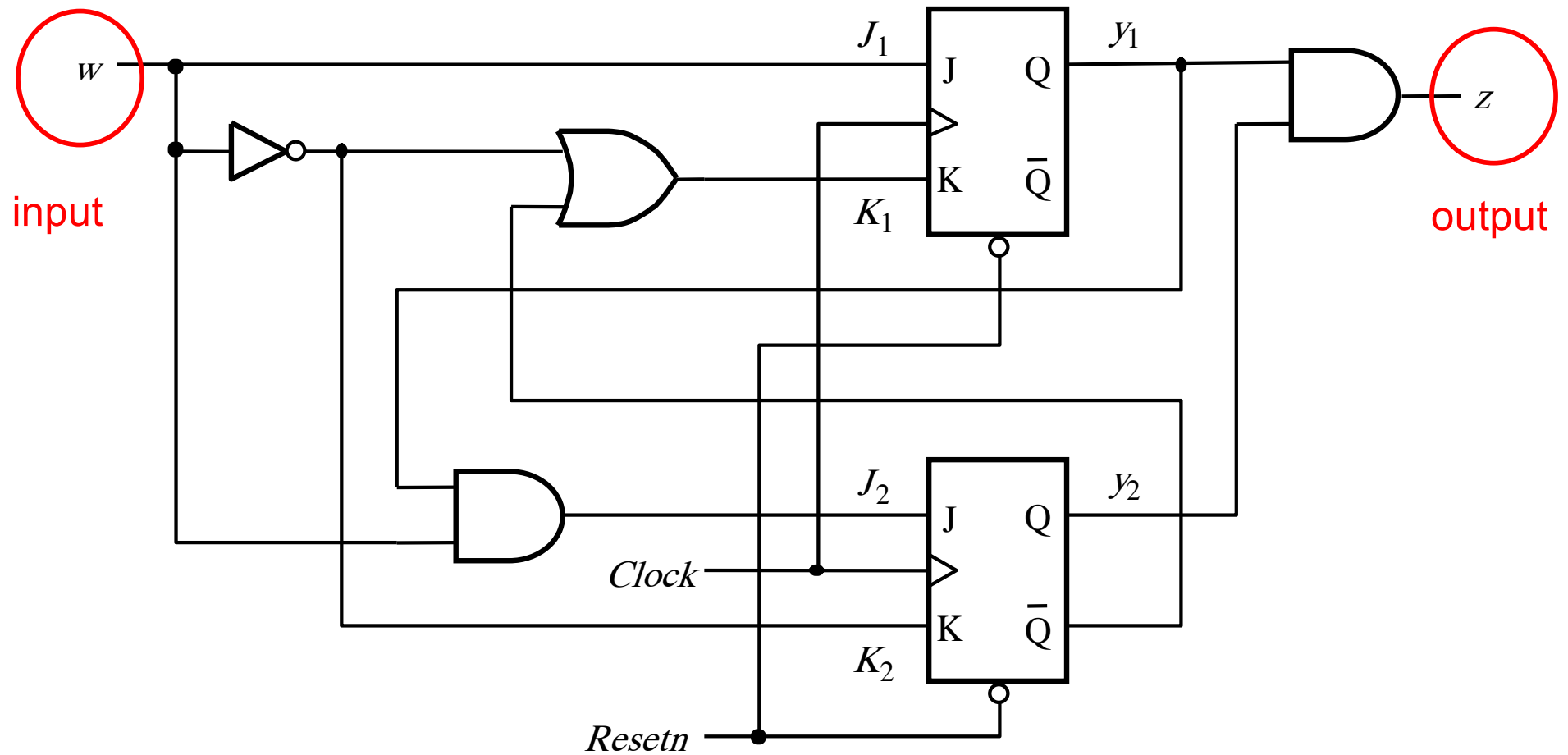

Where are the flip-flops?

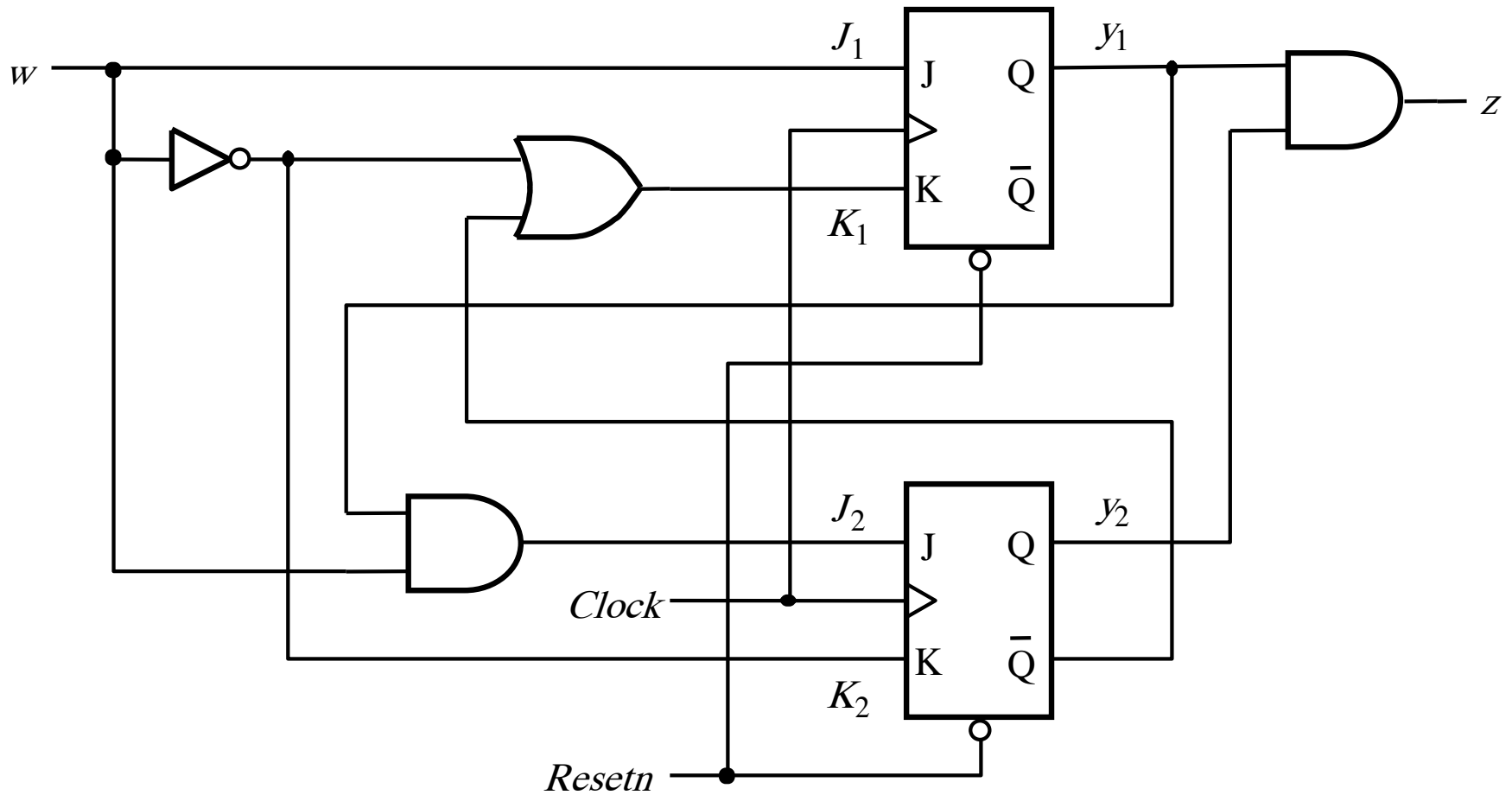

Where are the flip-flops?

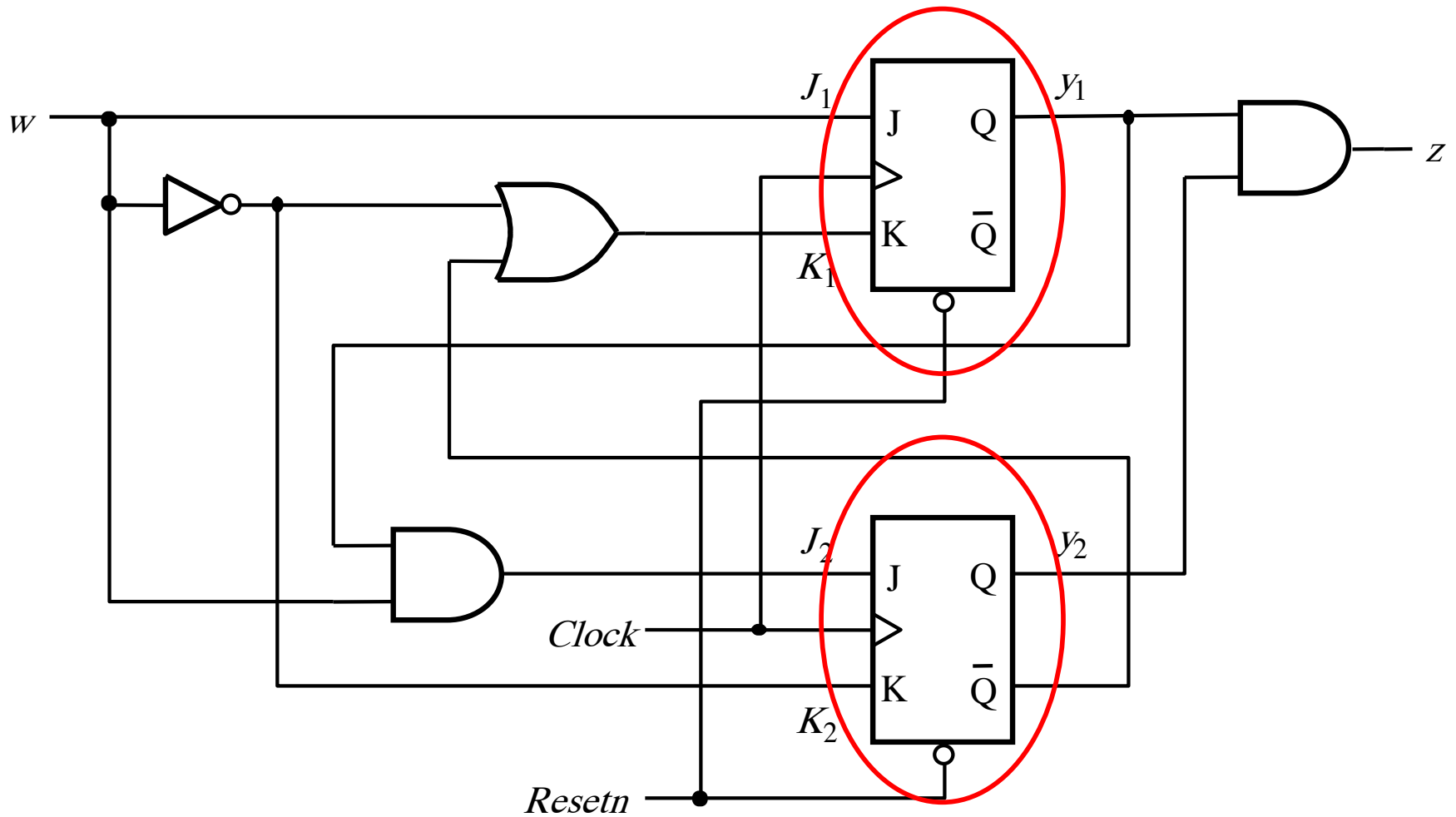

Where are the outputs of the flip-flops?

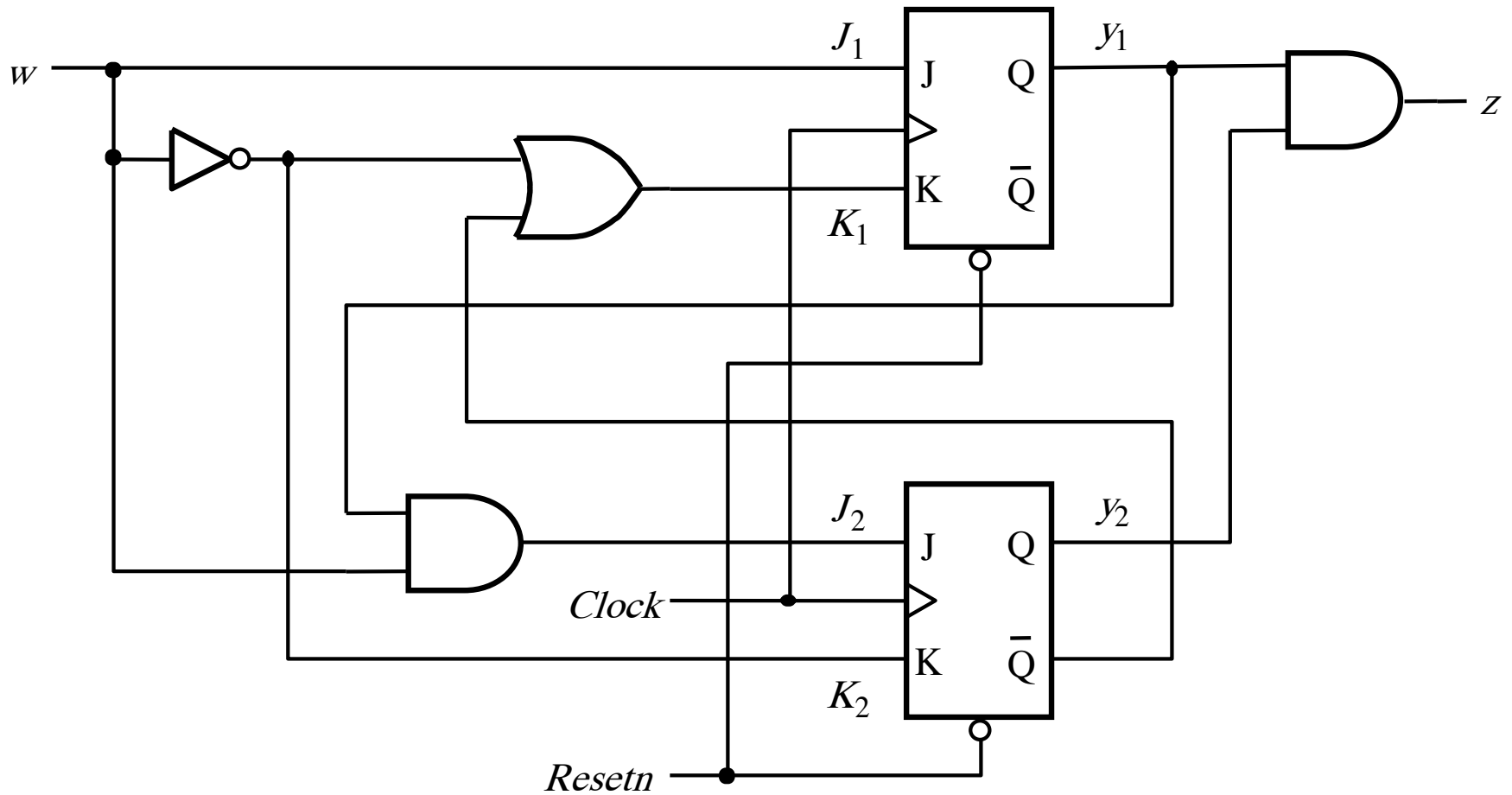

Where are the outputs of the flip-flops?

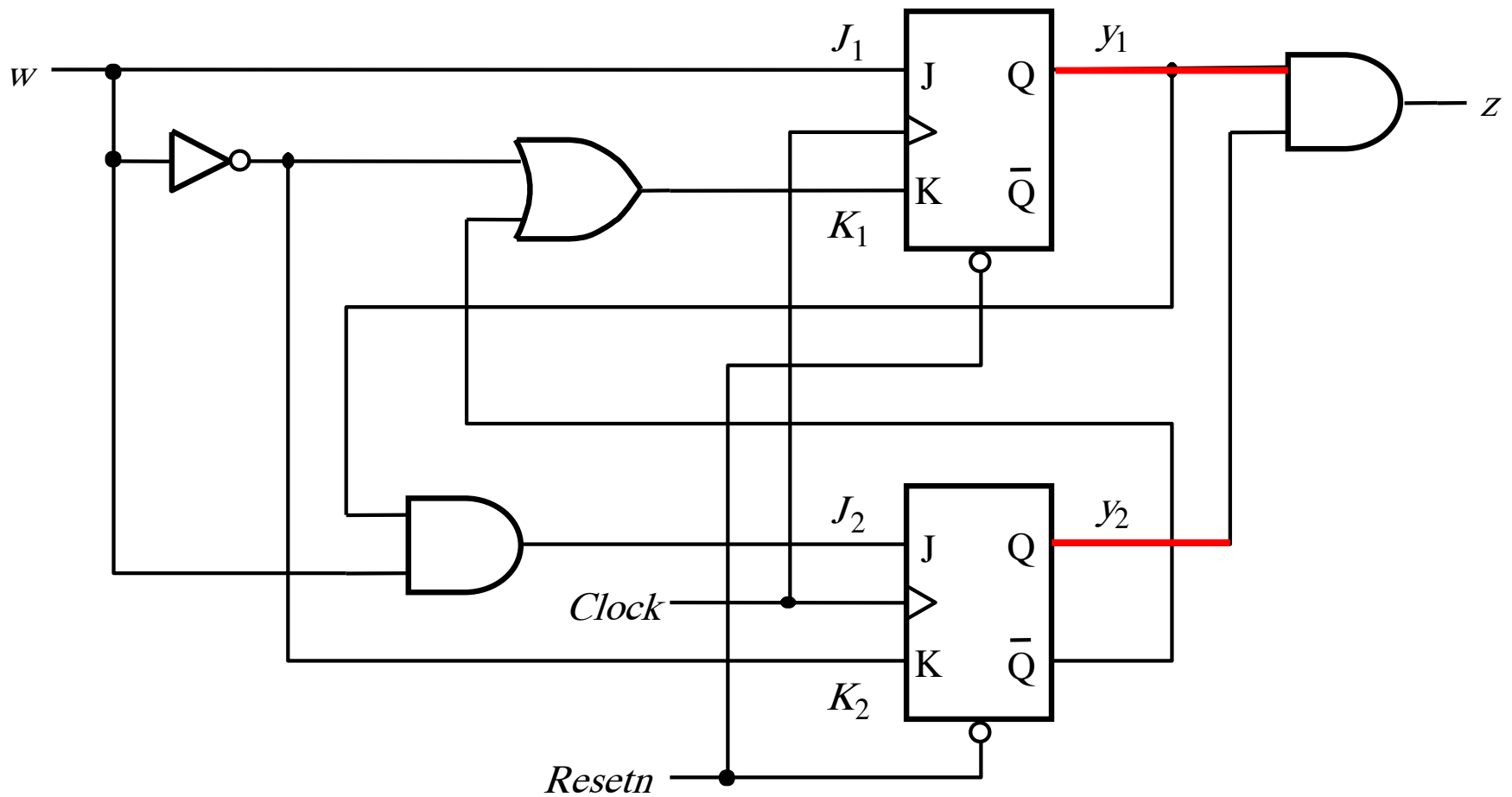

These are the next-state variables

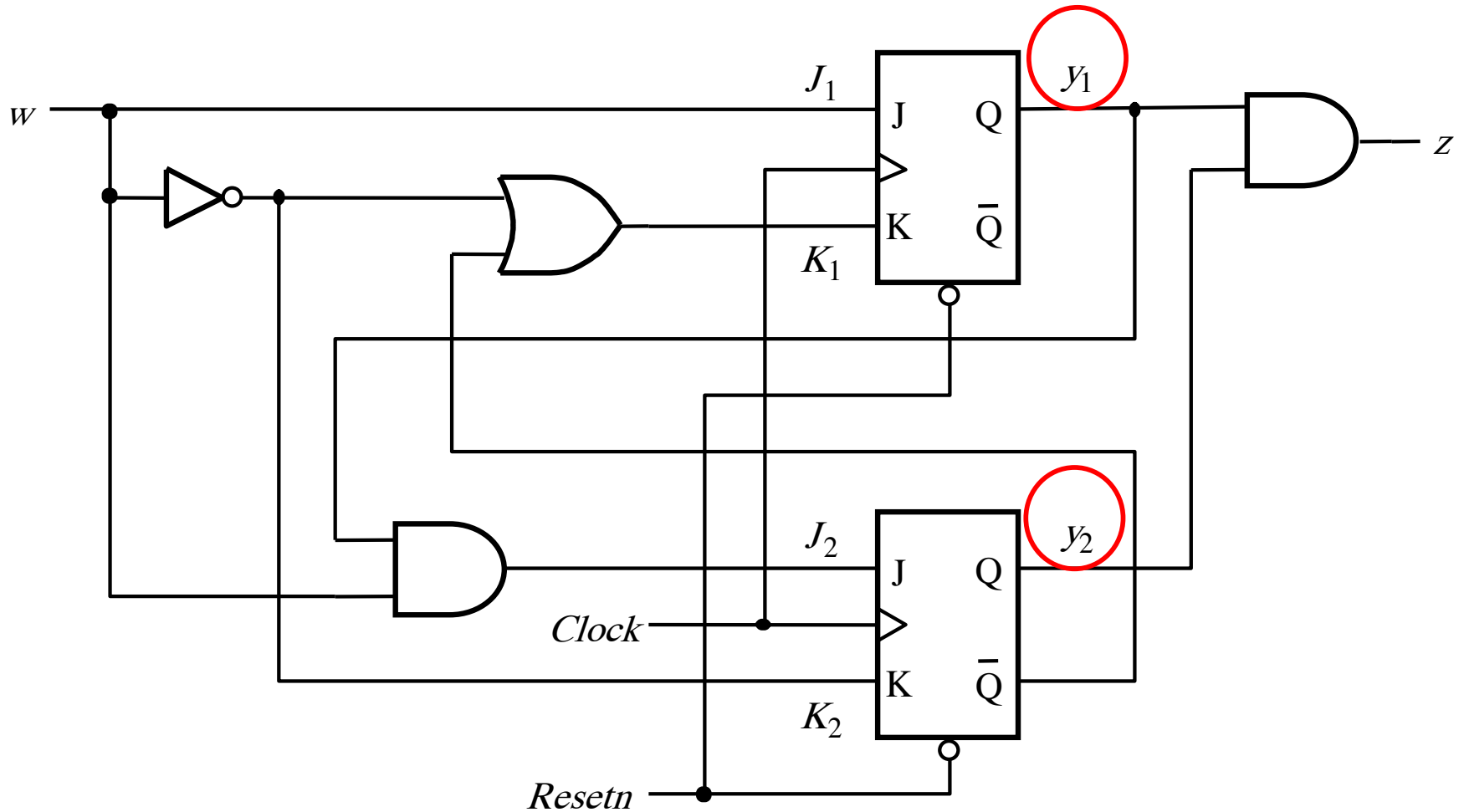

Where are the inputs of the flip-flops?

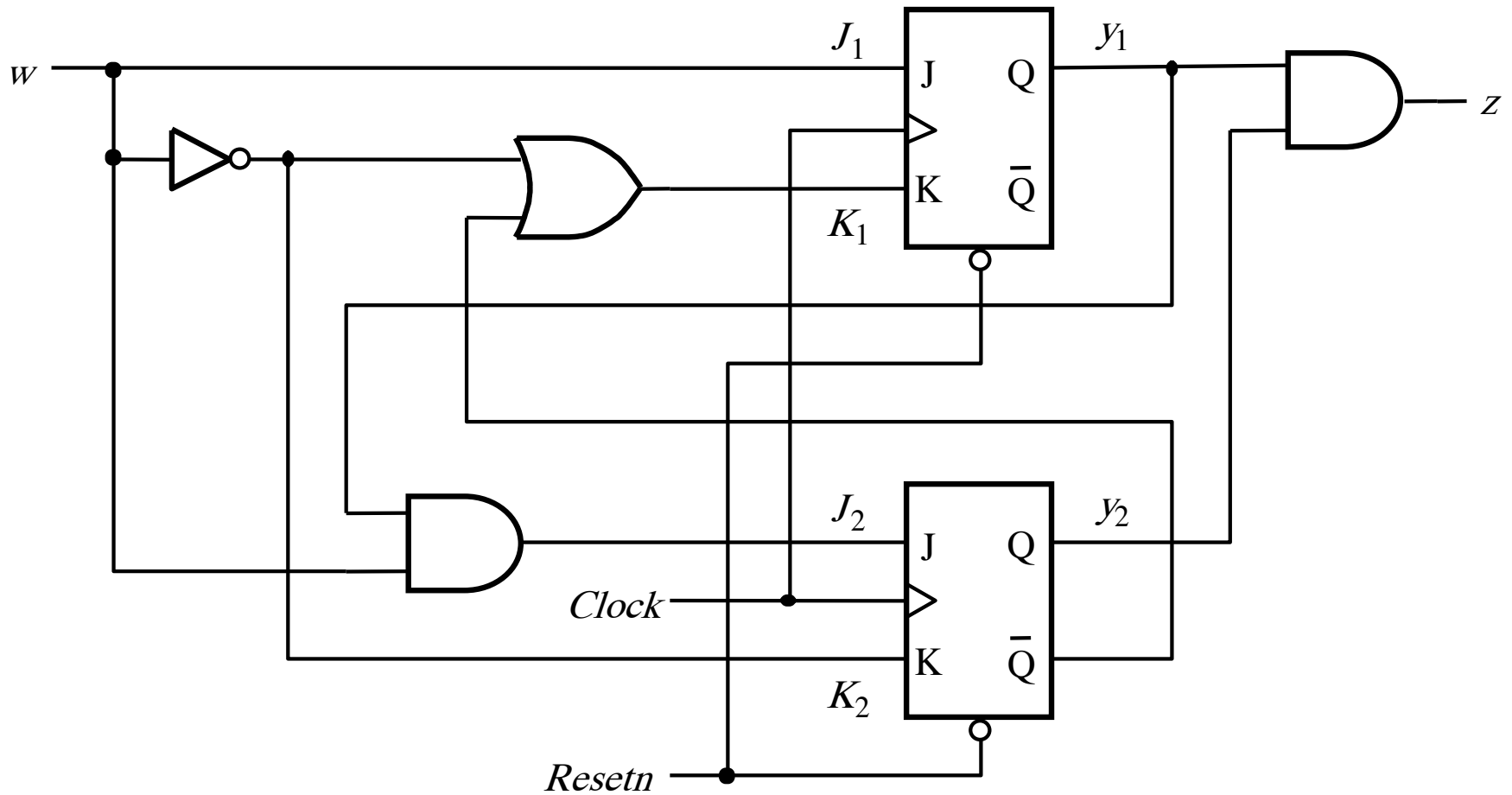

Where are the inputs of the flip-flops?

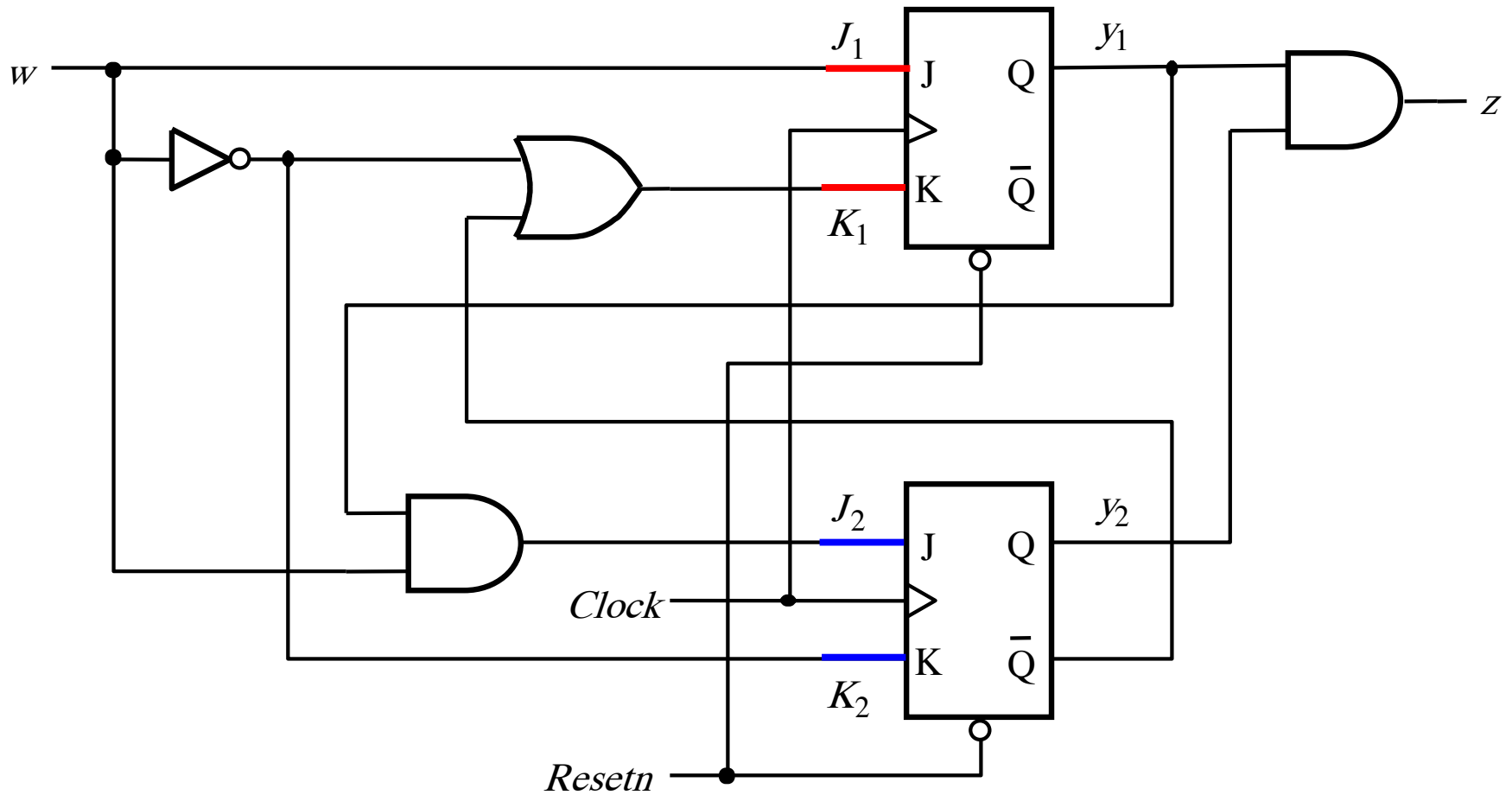

What are their logic expressions?

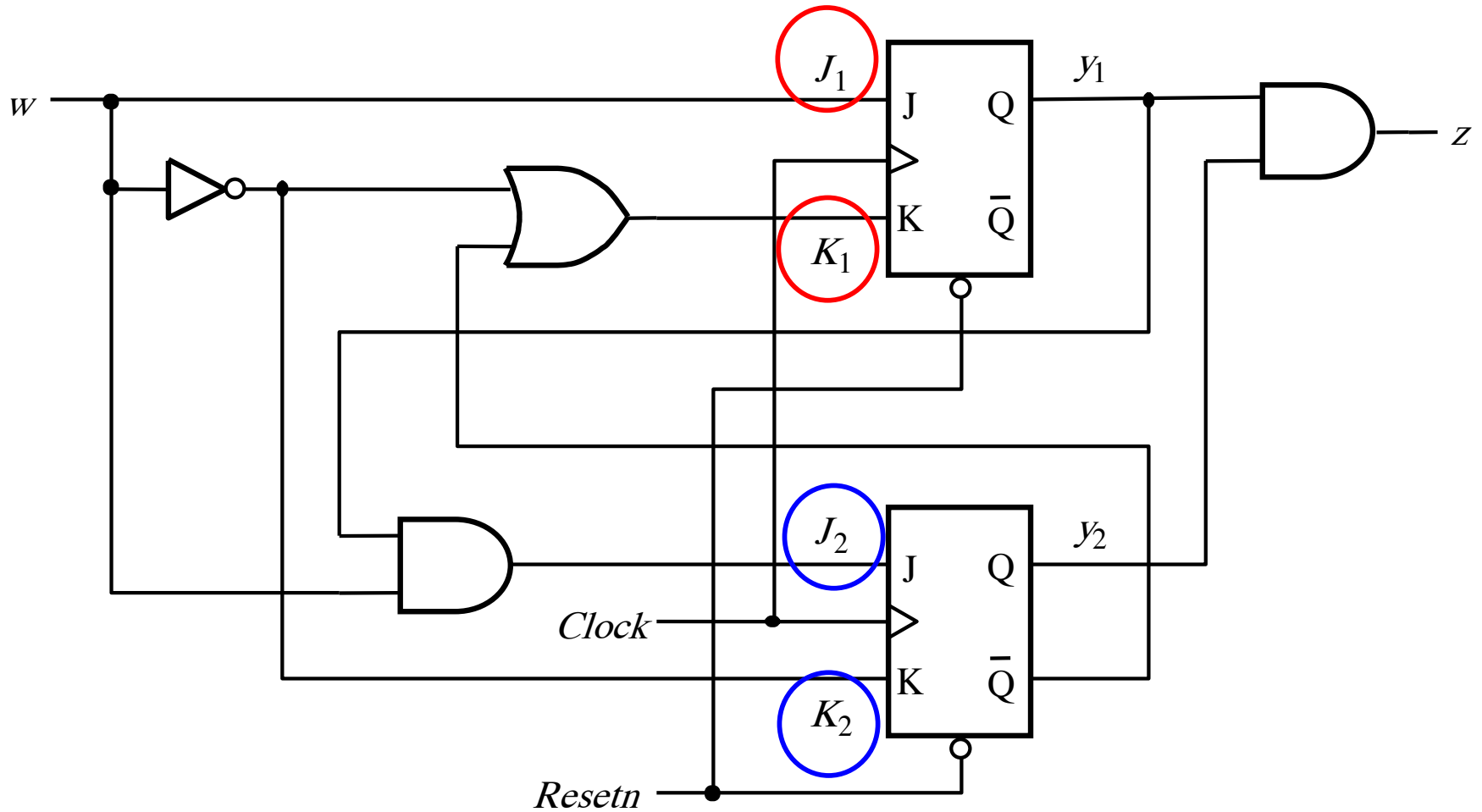

What are their logic expressions?

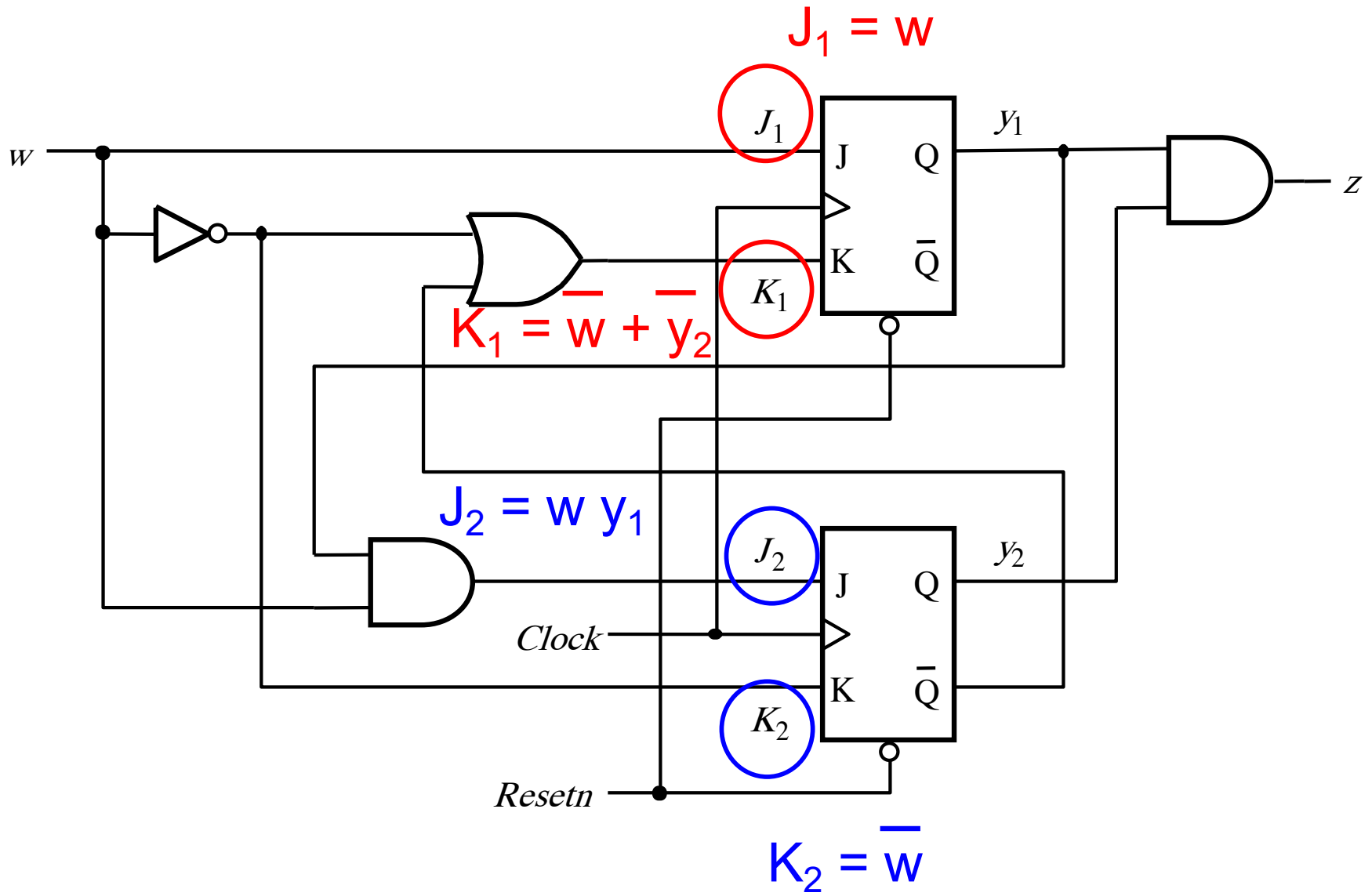

What is the logic expression of the output?

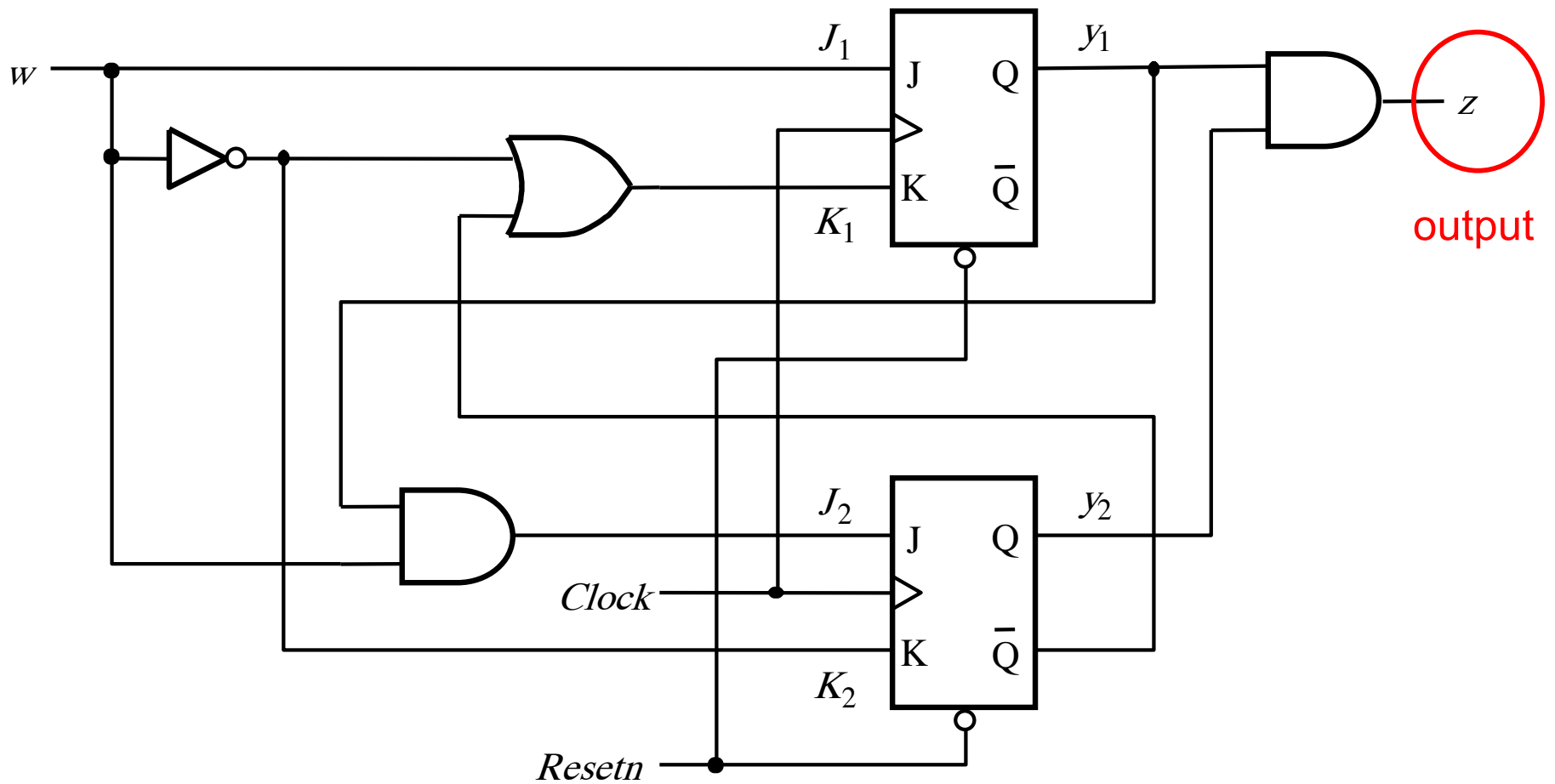

What is the logic expression of the output?

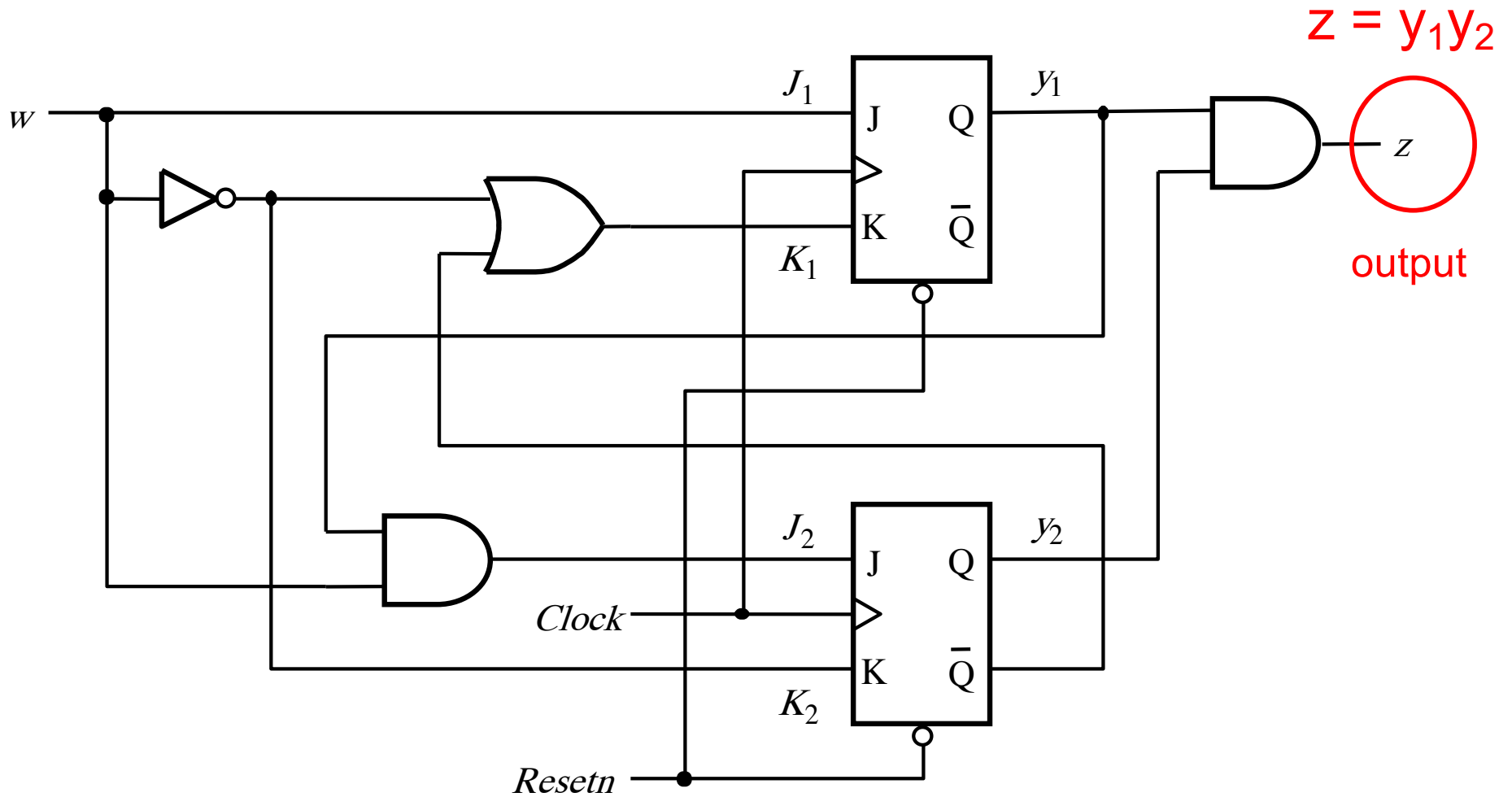

**This is what we have to work with now
(we don't need the circuit anymore)**

$$J_1 = w$$

$$K_1 = \bar{w} + \bar{y}_2$$

$$J_2 = w y_1$$

$$K_2 = \bar{w}$$

$$z = y_1 y_2$$

Let's derive the excitation table

$$J_1 = w$$

$$K_1 = \bar{w} + \bar{y}_2$$

$$J_2 = w y_1$$

$$K_2 = \bar{w}$$

$$z = y_1 y_2$$

Present state $y_2 y_1$	Flip-flop inputs				Output z
	$w = 0$		$w = 1$		
	$J_2 K_2$	$J_1 K_1$	$J_2 K_2$	$J_1 K_1$	
00					
01					
10					
11					

Let's derive the excitation table

$$J_1 = w$$

$$K_1 = \bar{w} + \bar{y}_2$$

$$J_2 = w y_1$$

$$K_2 = \bar{w}$$

Present state y_2y_1	Flip-flop inputs				Output z
	$w = 0$		$w = 1$		
	J_2K_2	J_1K_1	J_2K_2	J_1K_1	
00					
01					
10					
11					

$$z = y_1y_2$$

Let's derive the excitation table

$$J_1 = w$$

$$K_1 = \bar{w} + \bar{y}_2$$

$$J_2 = w y_1$$

$$K_2 = \bar{w}$$

Present state y_2y_1	Flip-flop inputs				Output z
	$w = 0$		$w = 1$		
	J_2K_2	J_1K_1	J_2K_2	J_1K_1	
00					0
01					0
10					0
11					1

$$z = y_1y_2$$

Let's derive the excitation table

$$J_1 = w$$

$$K_1 = \bar{w} + \bar{y}_2$$

$$J_2 = w y_1$$

$$K_2 = \bar{w}$$

$$z = y_1 y_2$$

Present state $y_2 y_1$	Flip-flop inputs				Output z
	$w = 0$		$w = 1$		
	$J_2 K_2$	$J_1 K_1$	$J_2 K_2$	$J_1 K_1$	
00					0
01					0
10					0
11					1

Let's derive the excitation table

$$J_1 = w$$

$$K_1 = \bar{w} + \bar{y}_2$$

$$J_2 = w y_1$$

$$K_2 = \bar{w}$$

$$z = y_1 y_2$$

Present state $y_2 y_1$	Flip-flop inputs				Output z
	$w = 0$		$w = 1$		
	$J_2 K_2$	$J_1 K_1$	$J_2 K_2$	$J_1 K_1$	
00		0 1		1 1	0
01		0 1		1 1	0
10		0 1		1 0	0
11		0 1		1 0	1

Let's derive the excitation table

$$J_1 = w$$

$$K_1 = \bar{w} + \bar{y}_2$$

$$J_2 = w y_1$$

$$K_2 = \bar{w}$$

Present state y_2y_1	Flip-flop inputs				Output z
	$w = 0$		$w = 1$		
	J_2K_2	J_1K_1	J_2K_2	J_1K_1	
00		01		11	0
01		01		11	0
10		01		10	0
11		01		10	1

$$z = y_1y_2$$

The excitation table

$$J_1 = w$$

$$K_1 = \bar{w} + \bar{y}_2$$

$$J_2 = w y_1$$

$$K_2 = \bar{w}$$

$$z = y_1 y_2$$

Present state $y_2 y_1$	Flip-flop inputs				Output z
	$w = 0$		$w = 1$		
	$J_2 K_2$	$J_1 K_1$	$J_2 K_2$	$J_1 K_1$	
00	01	01	00	11	0
01	01	01	10	11	0
10	01	01	00	10	0
11	01	01	10	10	1

We don't need the logic expressions anymore

$$J_1 = w$$

$$K_1 = \bar{w} + \bar{y}_2$$

$$J_2 = w y_1$$

$$K_2 = \bar{w}$$

$$z = y_1 y_2$$

Present state $y_2 y_1$	Flip-flop inputs				Output z
	$w = 0$		$w = 1$		
	$J_2 K_2$	$J_1 K_1$	$J_2 K_2$	$J_1 K_1$	
00	01	01	00	11	0
01	01	01	10	11	0
10	01	01	00	10	0
11	01	01	10	10	1

We don't need the logic expressions anymore

Present state y_2y_1	Flip-flop inputs				Output z
	$w = 0$		$w = 1$		
	J_2K_2	J_1K_1	J_2K_2	J_1K_1	
00	01	01	00	11	0
01	01	01	10	11	0
10	01	01	00	10	0
11	01	01	10	10	1

Let's derive the state table

Present state	Next state		Output z
	w = 0	w = 1	

State table

Present state y_2y_1	Flip-flop inputs				Output z
	w = 0		w = 1		
	J_2K_2	J_1K_1	J_2K_2	J_1K_1	
00	01	01	00	11	0
01	01	01	10	11	0
10	01	01	00	10	0
11	01	01	10	10	1

Excitation table

Let's derive the state table

Present state	Next state		Output z
	w = 0	w = 1	
A			
B			
C			
D			

Present state y_2y_1	Flip-flop inputs				Output z
	w = 0		w = 1		
	J_2K_2	J_1K_1	J_2K_2	J_1K_1	
00	01	01	00	11	0
01	01	01	10	11	0
10	01	01	00	10	0
11	01	01	10	10	1

State table

Excitation table

This step is easy
(map 2-bit numbers to 4 letters)

Let's derive the state table

Present state	Next state		Output z
	w = 0	w = 1	
A			0
B			0
C			0
D			1

State table

Present state y_2y_1	Flip-flop inputs				Output z
	w = 0		w = 1		
	J_2K_2	J_1K_1	J_2K_2	J_1K_1	
00	01	01	00	11	0
01	01	01	10	11	0
10	01	01	00	10	0
11	01	01	10	10	1

Excitation table

This step is easy too
(the outputs are the same in both tables)

Let's derive the state table

Present state	Next state		Output z
	w = 0	w = 1	
A	?		0
B			0
C			0
D			1

State table

Present state y_2y_1	Flip-flop inputs				Output z
	w = 0		w = 1		
	J_2K_2	J_1K_1	J_2K_2	J_1K_1	
00	01	01	00	11	0
01	01	01	10	11	0
10	01	01	00	10	0
11	01	01	10	10	1

Excitation table

How should we do this?

JK Flip-Flop Refresher

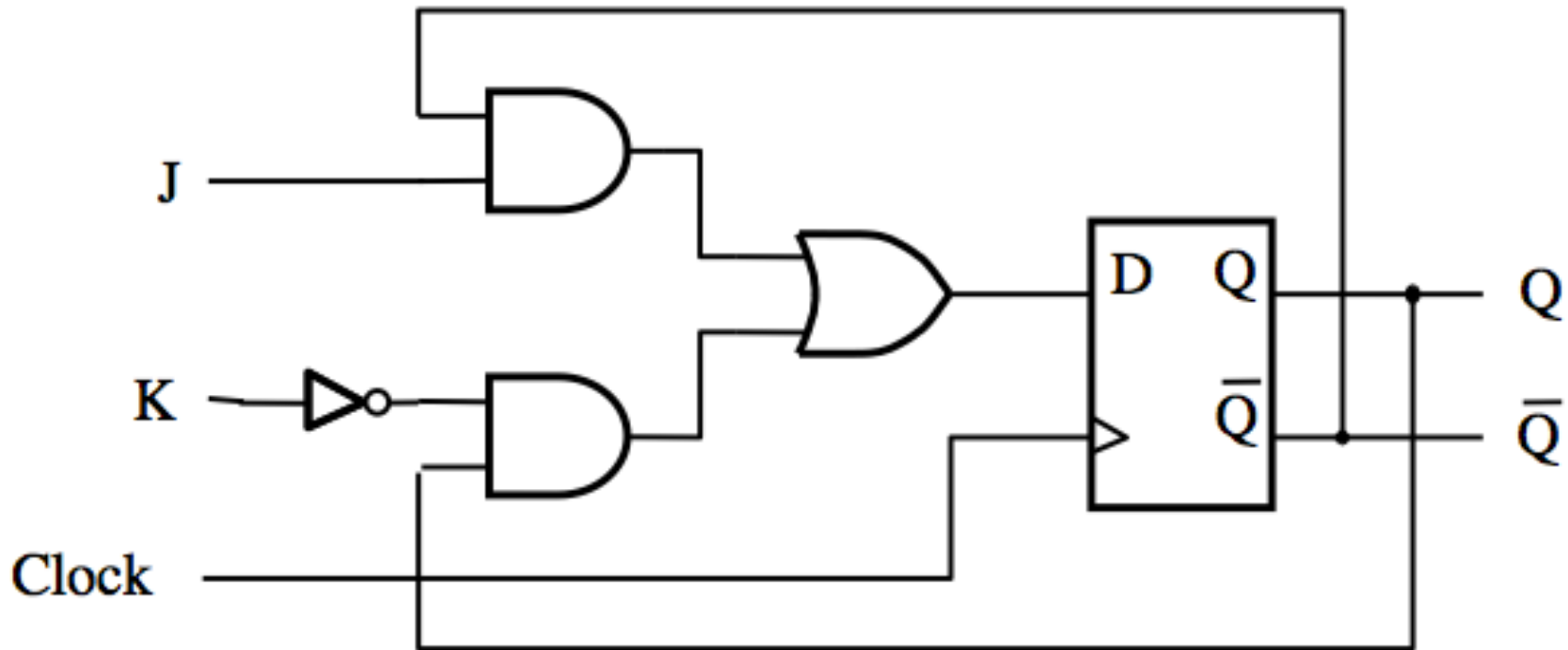

$$D = \bar{J}\bar{Q} + \bar{K}Q$$

JK Flip-Flop Refresher

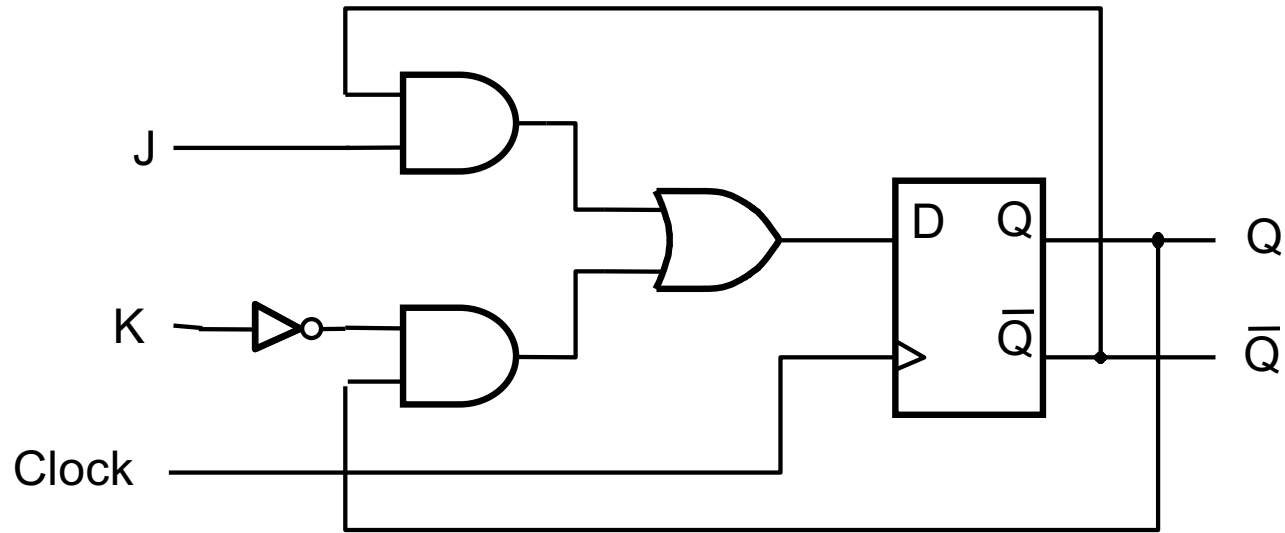

(a) Circuit

J	K	$Q(t+1)$
0	0	$Q(t)$
0	1	0
1	0	1
1	1	$\bar{Q}(t)$

(b) Truth table

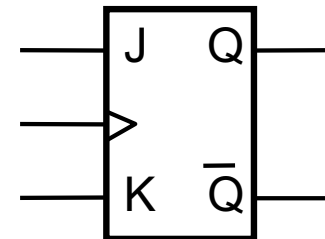

(c) Graphical symbol

Let's derive the state table

Present state	Next state		Output z
	w = 0	w = 1	
A	?		0
B			0
C			0
D			1

State table

Present state y_2y_1	Flip-flop inputs				Output z
	w = 0		w = 1		
	J_2K_2	J_1K_1	J_2K_2	J_1K_1	
00	01	01	00	11	0
01	01	01	10	11	0
10	01	01	00	10	0
11	01	01	10	10	1

Excitation table

How should we do this?

Let's derive the state table

Present state	Next state		Output z
	w = 0	w = 1	
A			0
B			0
C			0
D			1

Present state y_2y_1	Flip-flop inputs				Output z
	w = 0		w = 1		
	J_2K_2	J_1K_1	J_2K_2	J_1K_1	
00	01	01	00	11	0
01	01	01	10	11	0
10	01	01	00	10	0
11	01	01	10	10	1

J K	Q(t+1)
0 0	Q(t)
0 1	0
1 0	1
1 1	$\bar{Q}(t)$

Let's derive the state table

Present state	Next state		Output z
	w = 0	w = 1	
A			0
B			0
C			0
D			1

Present state y_2y_1	Flip-flop inputs				Output z
	w = 0		w = 1		
	J_2K_2	J_1K_1	J_2K_2	J_1K_1	
00	01	01	00	11	0
01	01	01	10	11	0
10	01	01	00	10	0
11	01	01	10	10	1

J	K	$Q(t+1)$
0	0	$Q(t)$
0	1	0
1	0	1
1	1	$\bar{Q}(t)$

J	K	$Q(t+1)$
0	0	$Q(t)$
0	1	0
1	0	1
1	1	$\bar{Q}(t)$

Let's derive the state table

Present state	Next state		Output z
	w = 0	w = 1	
A	A		0
B			0
C			0
D			1

Present state y_2y_1	Flip-flop inputs				Output z
	w = 0		w = 1		
	J_2K_2	J_1K_1	J_2K_2	J_1K_1	
00	01	01	00	11	0
01	01	01	10	11	0
10	01	01	00	10	0
11	01	01	10	10	1

Note that A = 00

J	K	$Q(t+1)$	J	K	$Q(t+1)$
0	0	$Q(t)$	0	0	$Q(t)$
0	1	0	0	1	0
1	0	1	1	0	1
1	1	$\bar{Q}(t)$	1	1	$\bar{Q}(t)$

Let's derive the state table

Present state	Next state		Output z
	w = 0	w = 1	
A	A	?	0
B			0
C			0
D			1

Present state y_2y_1	Flip-flop inputs				Output z
	w = 0		w = 1		
	J_2K_2	J_1K_1	J_2K_2	J_1K_1	
00	01	01	00	11	0
01	01	01	10	11	0
10	01	01	00	10	0
11	01	01	10	10	1

J	K	$Q(t+1)$	J	K	$Q(t+1)$
0	0	$Q(t)$	0	0	$Q(t)$
0	1	0	0	1	0
1	0	1	1	0	1
1	1	$\bar{Q}(t)$	1	1	$\bar{Q}(t)$

Let's derive the state table

Present state	Next state		Output z
	w = 0	w = 1	
A	A		0
B			0
C			0
D			1

Present state y_2y_1	Flip-flop inputs				Output z
	w = 0		w = 1		
	J_2K_2	J_1K_1	J_2K_2	J_1K_1	
00	01	01	00	11	0
01	01	01	10	11	0
10	01	01	00	10	0
11	01	01	10	10	1

J K	Q(t+1)	J K	Q(t+1)
0 0	Q(t)	0 0	Q(t)
0 1	0	0 1	0
1 0	1	1 0	1
1 1	$\bar{Q}(t)$	1 1	$\bar{Q}(t)$

Let's derive the state table

Present state	Next state		Output z
	w = 0	w = 1	
A	A		0
B			0
C			0
D			1

Present state y_2y_1	Flip-flop inputs				Output z
	w = 0		w = 1		
	J_2K_2	J_1K_1	J_2K_2	J_1K_1	
00	01	01	00	11	0
01	01	01	10	11	0
10	01	01	00	10	0
11	01	01	10	10	1

J	K	$Q(t+1)$	J	K	$Q(t+1)$
0	0	$Q(t)$	0	0	$Q(t)$
0	1	0	0	1	0
1	0	1	1	0	1
1	1	$\bar{Q}(t)$	1	1	$\bar{Q}(t)$

Let's derive the state table

Present state	Next state		Output z
	w = 0	w = 1	
A	A		0
B			0
C			0
D			1

Present state y_2y_1	Flip-flop inputs				Output z
	w = 0		w = 1		
	J_2K_2	J_1K_1	J_2K_2	J_1K_1	
00	01	01	00	11	0
01	01	01	10	11	0
10	01	01	00	10	0
11	01	01	10	10	1

J	K	$Q(t+1)$	J	K	$Q(t+1)$
0	0	$Q(t)$	0	0	$Q(t)$
0	1	0	0	1	0
1	0	1	1	0	1
1	1	$\bar{Q}(t)$	1	1	$\bar{Q}(t)$

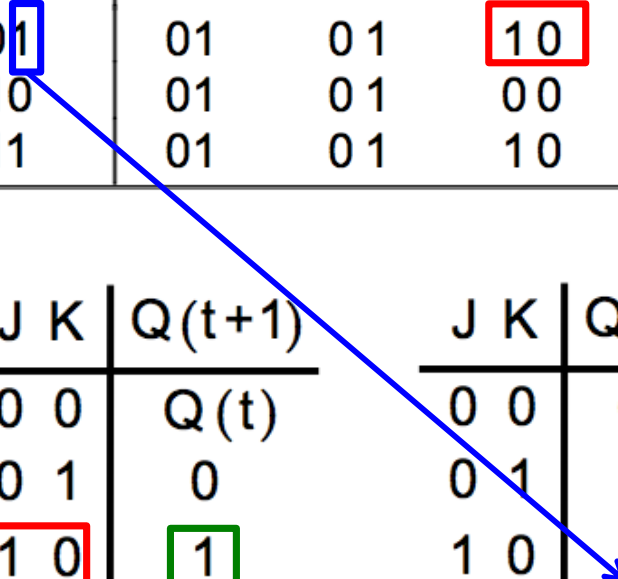

Let's derive the state table

Present state	Next state		Output z
	w = 0	w = 1	
A	A		0
B			0
C			0
D			1

Present state y_2y_1	Flip-flop inputs				Output z
	w = 0		w = 1		
	J_2K_2	J_1K_1	J_2K_2	J_1K_1	
00	01	01	00	11	0
01	01	01	10	11	0
10	01	01	00	10	0
11	01	01	10	10	1

J	K	$Q(t+1)$	J	K	$Q(t+1)$
0	0	$Q(t)$	0	0	$Q(t)$
0	1	0	0	1	0
1	0	1	1	0	1
1	1	$\bar{Q}(t)$	1	1	$\bar{Q}(t)$

$\bar{1} = 0$

Let's derive the state table

Present state	Next state		Output z
	w = 0	w = 1	
A	A		0
B		C	0
C			0
D			1

Present state y_2y_1	Flip-flop inputs				Output z
	w = 0		w = 1		
	J_2K_2	J_1K_1	J_2K_2	J_1K_1	
00	01	01	00	11	0
01	01	01	10	11	0
10	01	01	00	10	0
11	01	01	10	10	1

Note that C = 10

J	K	$Q(t+1)$	J	K	$Q(t+1)$
0	0	$Q(t)$	0	0	$Q(t)$
0	1	0	0	1	0
1	0	1	1	0	1
1	1	$\bar{Q}(t)$	1	1	$\bar{Q}(t)$ = 0

The two tables for the initial circuit

Present state	Next state		Output z
	w = 0	w = 1	
A	A	B	0
B	A	C	0
C	A	D	0
D	A	D	1

State table

Present state y_2y_1	Flip-flop inputs				Output z
	w = 0		w = 1		
	J_2K_2	J_1K_1	J_2K_2	J_1K_1	
00	01	01	00	11	0
01	01	01	10	11	0
10	01	01	00	10	0
11	01	01	10	10	1

Excitation table

The state diagram

Present state	Next state		Output z
	w = 0	w = 1	
A	A	B	0
B	A	C	0
C	A	D	0
D	A	D	1

State table

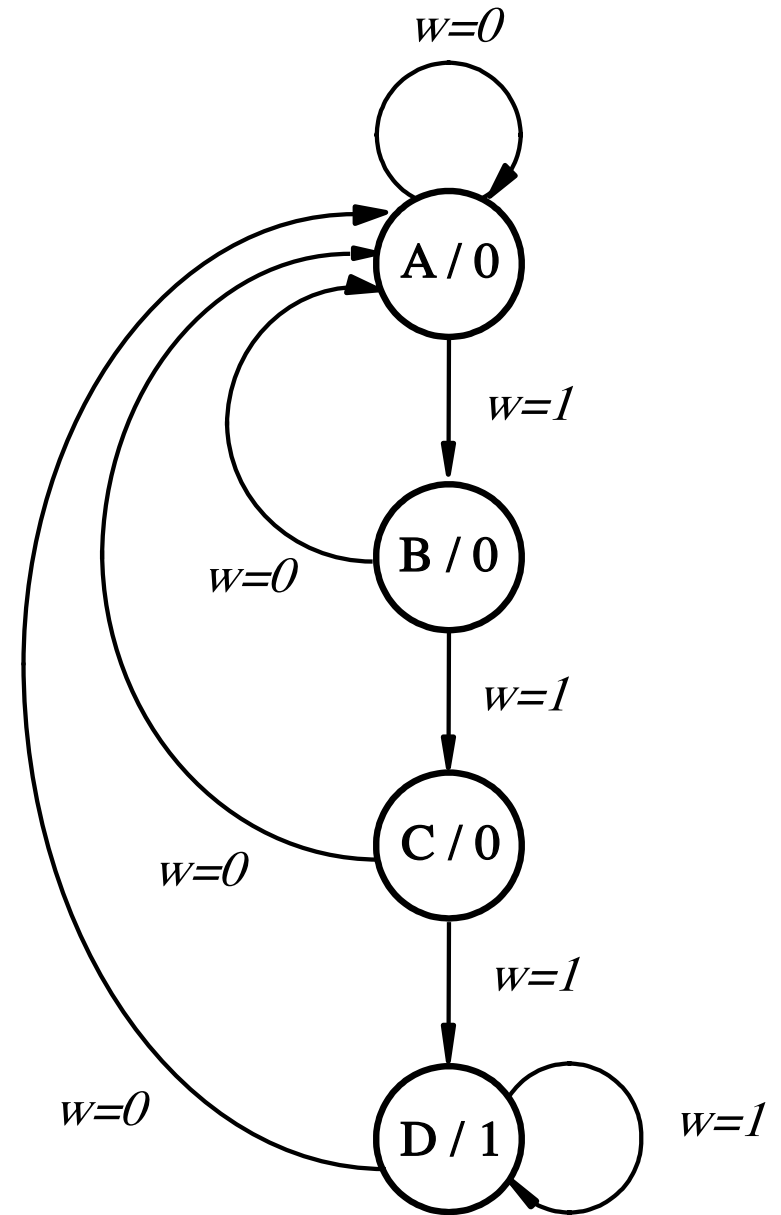

State diagram

The state diagram

Thus, this FSM is identical to the one in the previous example, even though the circuit uses JK flip-flops.

Present state	Next state		Output z
	w = 0	w = 1	
A	A	B	0
B	A	C	0
C	A	D	0
D	A	D	1

State table

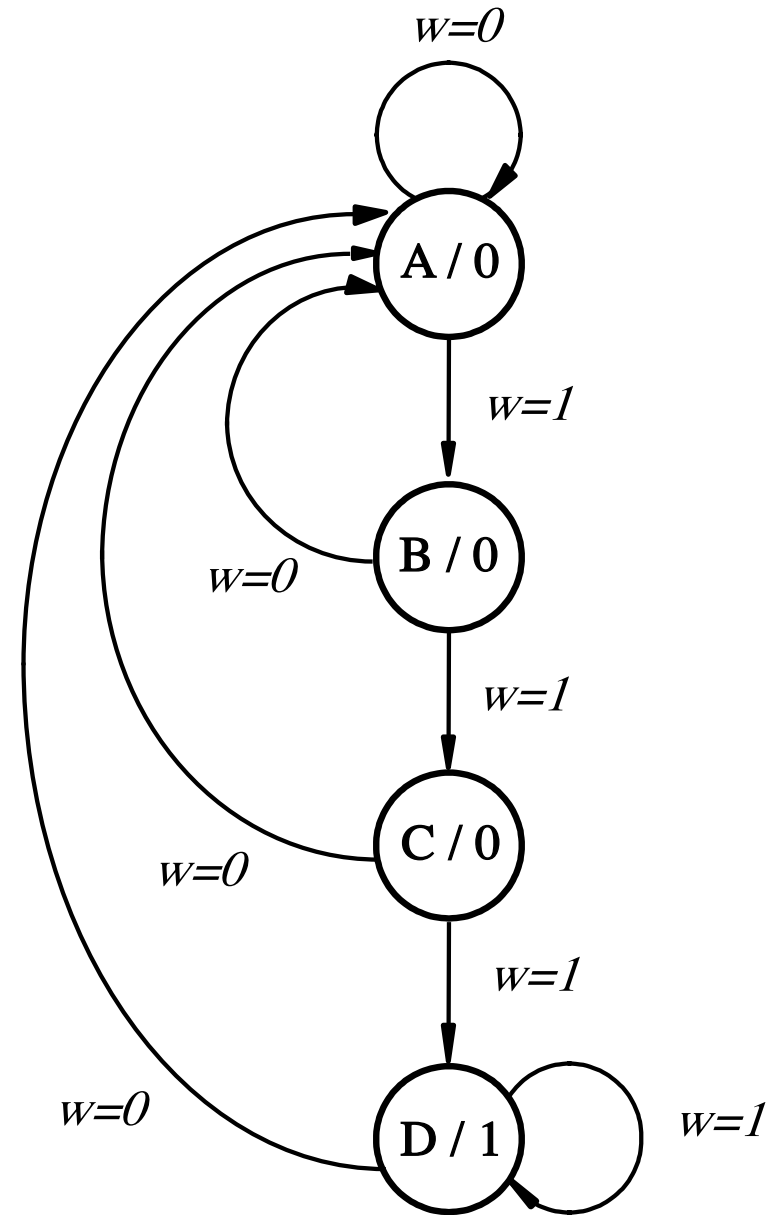

State diagram

Yet Another Example (with mixed flip-flops)

What does this circuit do?

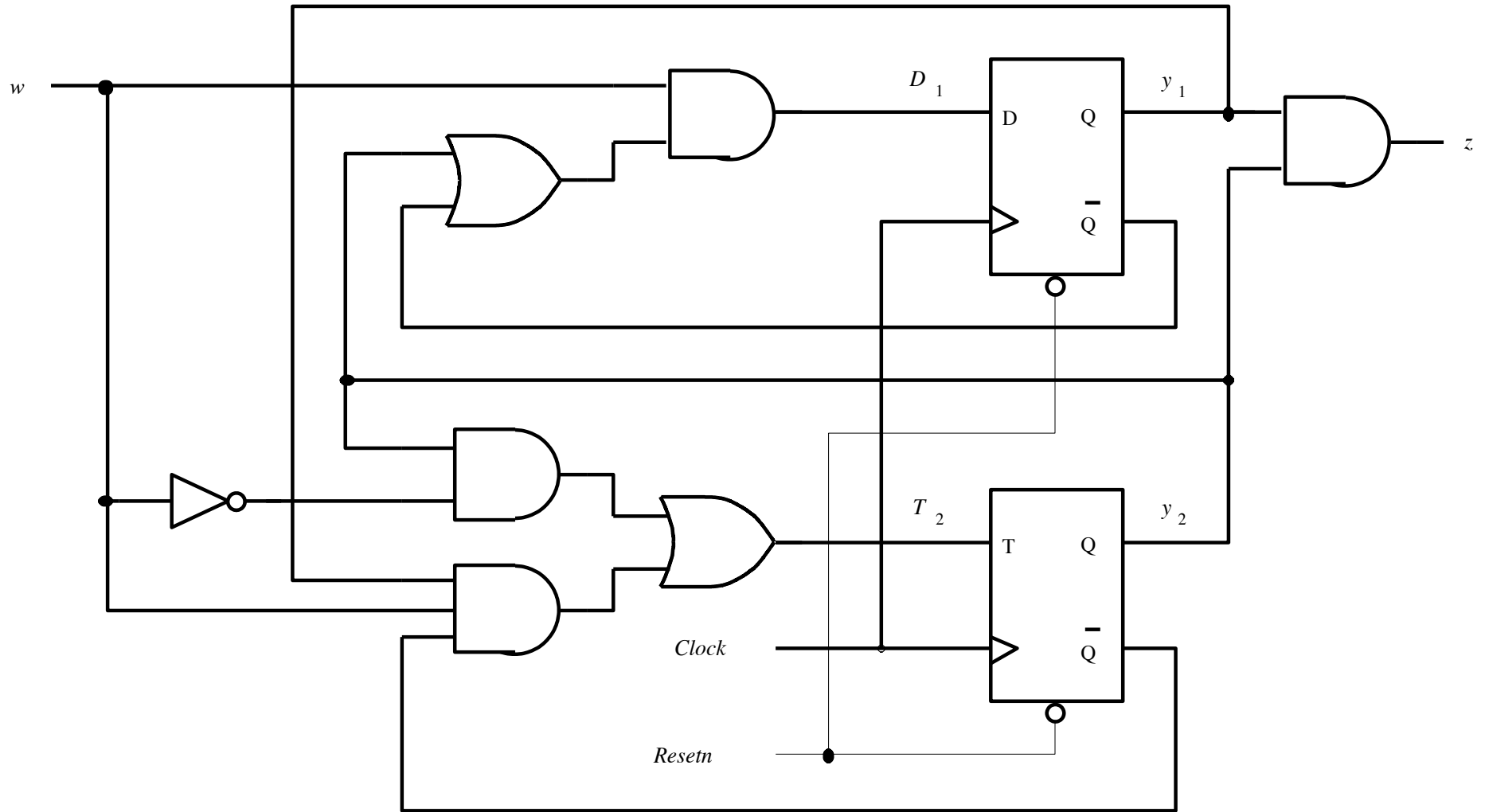

[Figure 6.79 from the textbook]

Approach

- **Find the flip-flops**
- **Outputs of the flip-flops = present state variables**
- **Inputs of the flip-flops determine the next state variables**
- **Determine the logical expressions for the outputs**
- **Given this info it is easy to do the state-assigned table**
- **Next do the state table**
- **Finally, draw the state diagram.**

What are the logic expressions?

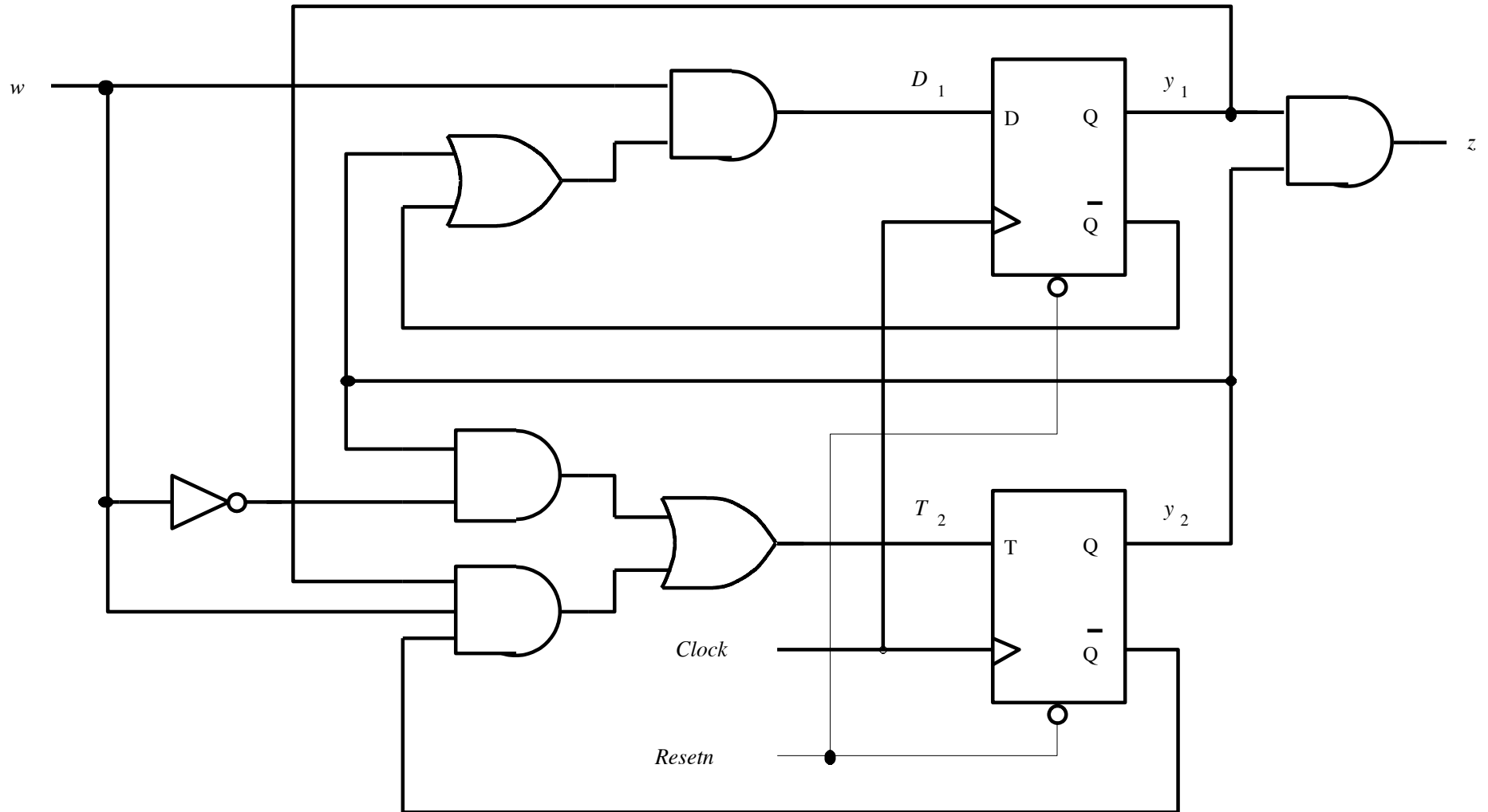

[Figure 6.79 from the textbook]

What are the logic expressions?

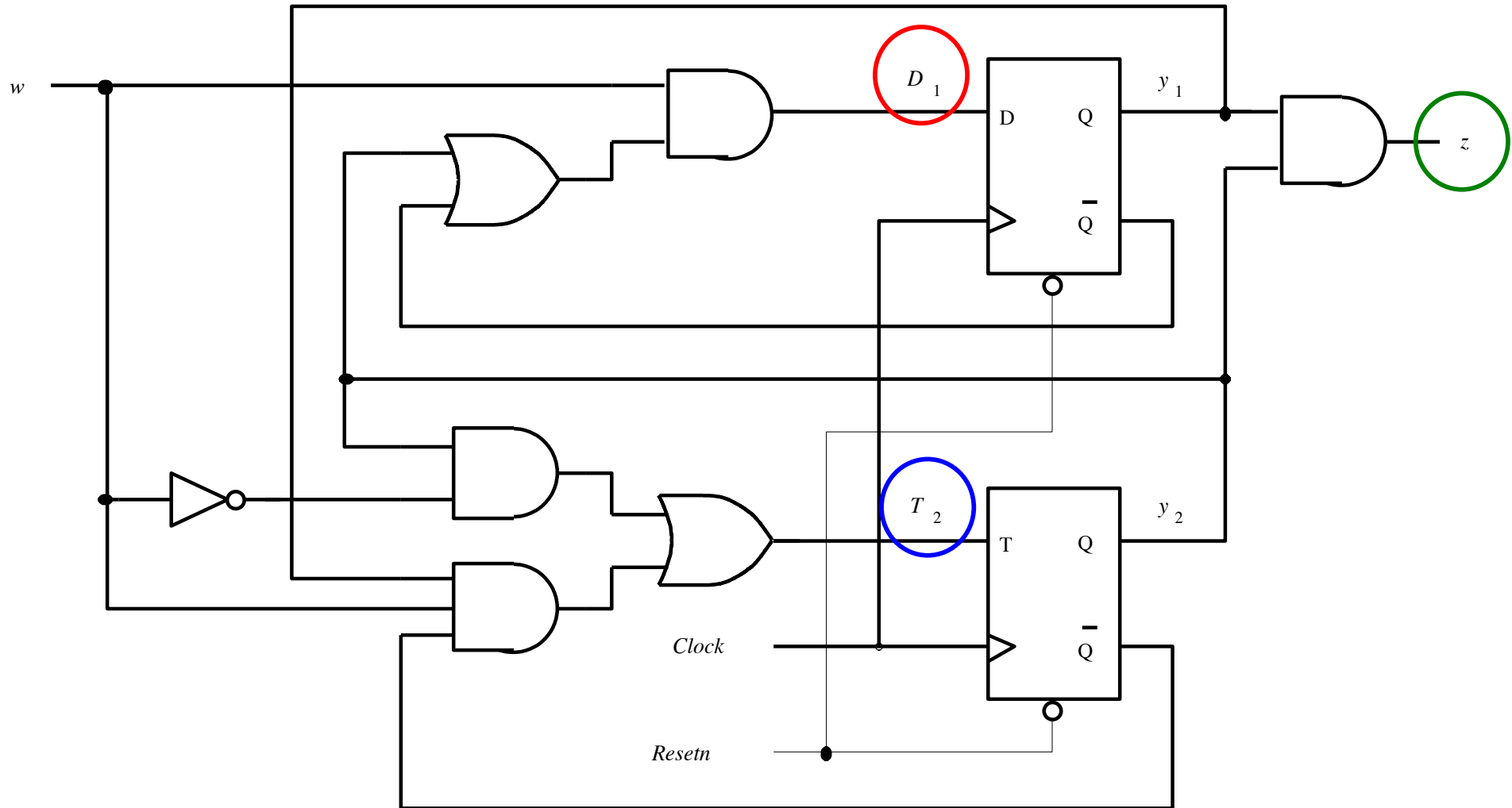

What are the logic expressions?

$$D_1 = w (\bar{y}_1 + y_2)$$

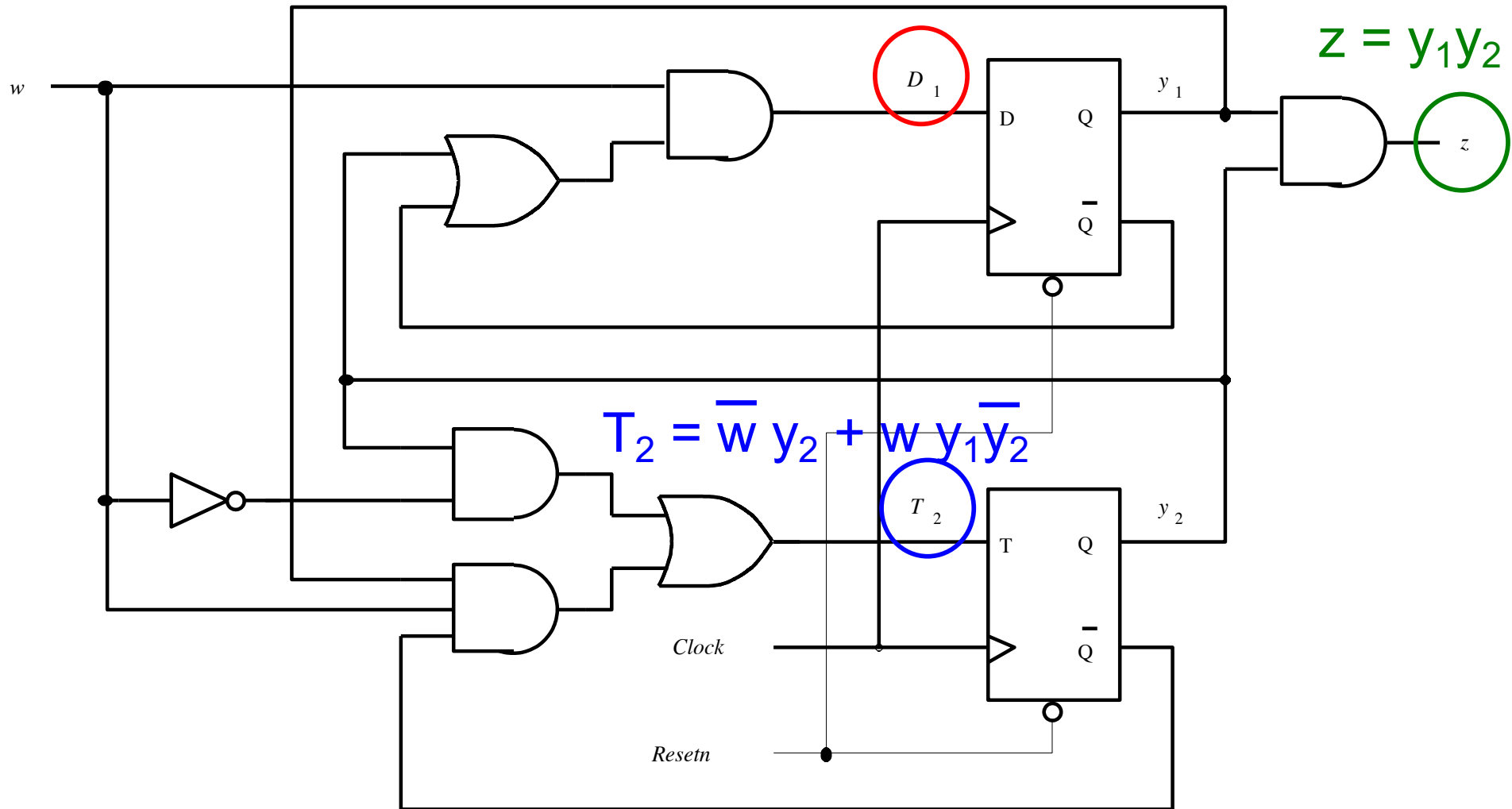

The Excitation Table

$$D_1 = w (\bar{y}_1 + y_2)$$

$$T_2 = \bar{w} y_2 + w y_1 \bar{y}_2$$

$$z = y_1 y_2$$

Present state $y_2 y_1$	Flip-flop inputs		Output z
	$w = 0$	$w = 1$	
	$T_2 D_1$	$T_2 D_1$	
00	00	01	0
01	00	10	0
10	10	01	0
11	10	01	1

Excitation table

Let's derive the state table

Present state	Next state		Output z
	w = 0	w = 1	

Present state y_2y_1	Flip-flop inputs		Output z
	w = 0	w = 1	
	T_2D_1	T_2D_1	
00	00	01	0
01	00	10	0
10	10	01	0
11	10	01	1

Let's derive the state table

Present state	Next state		Output z
	w = 0	w = 1	
A			
B			
C			
D			

Present state y_2y_1	Flip-flop inputs		Output z
	w = 0	w = 1	
	T_2D_1	T_2D_1	
00	00	01	0
01	00	10	0
10	10	01	0
11	10	01	1

This step is easy
(map 2-bit numbers to 4 letters)

Let's derive the state table

Present state	Next state		Output z
	w = 0	w = 1	
A			0
B			0
C			0
D			1

Present state y_2y_1	Flip-flop inputs		Output z
	w = 0	w = 1	
	T_2D_1	T_2D_1	
00	00	01	0
01	00	10	0
10	10	01	0
11	10	01	1

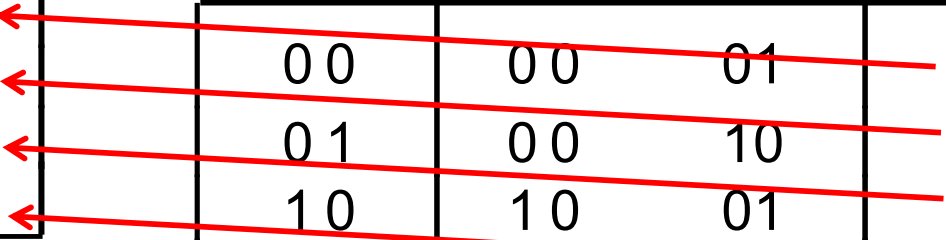

This step is easy too
(the outputs are the same in both tables)

Let's derive the state table

Present state	Next state		Output z
	w = 0	w = 1	
A	?		0
B			0
C			0
D			1

Present state y_2y_1	Flip-flop inputs		Output z
	w = 0	w = 1	
	T_2D_1	T_2D_1	
00	00	01	0
01	00	10	0
10	10	01	0
11	10	01	1

What should we do here?

Let's derive the state table

Present state	Next state		Output z
	w = 0	w = 1	
A	?		0
B			0
C			0
D			1

Present state y_2y_1	Flip-flop inputs		Output z
	w = 0	w = 1	
	T_2D_1	T_2D_1	
00	00	01	0
01	00	10	0
10	10	01	0
11	10	01	1

What should we do here?

T	$Q(t+1)$	D	$Q(t+1)$
0	$Q(t)$	0	0
1	$\overline{Q(t)}$	1	1

Let's derive the state table

Present state	Next state		Output z
	w = 0	w = 1	
A			0
B			0
C			0
D			1

Present state y_2y_1	Flip-flop inputs		Output z
	w = 0	w = 1	
	T_2D_1	T_2D_1	
00	00	01	0
01	00	10	0
10	10	01	0
11	10	01	1

T	$Q(t+1)$	D	$Q(t+1)$
0	$Q(t)$	0	0
1	$\overline{Q(t)}$	1	1

Let's derive the state table

Present state	Next state		Output z
	w = 0	w = 1	
A			0
B			0
C			0
D			1

Present state y_2y_1	Flip-flop inputs		Output z
	w = 0	w = 1	
	T_2D_1	T_2D_1	
00	00	01	0
01	00	10	0
10	10	01	0
11	10	01	1

T	$Q(t+1)$	D	$Q(t+1)$
0	$Q(t)$	0	0
1	$\overline{Q(t)}$	1	1

Let's derive the state table

Present state	Next state		Output z
	w = 0	w = 1	
A			0
B			0
C			0
D			1

Present state y_2y_1	Flip-flop inputs		Output z
	w = 0	w = 1	
	T_2D_1	T_2D_1	
00	00	01	0
01	00	10	0
10	10	01	0
11	10	01	1

T	$Q(t+1)$	D	$Q(t+1)$
0	$Q(t)$	0	0
1	$\bar{Q}(t)$	1	1

Let's derive the state table

Present state	Next state		Output z
	w = 0	w = 1	
A			0
B			0
C			0
D			1

Present state y_2y_1	Flip-flop inputs		Output z
	w = 0	w = 1	
	T_2D_1	T_2D_1	
00	00	01	0
01	00	10	0
10	10	01	0
11	10	01	1

T	$Q(t+1)$	D	$Q(t+1)$
0	0	0	0
1	$\bar{Q}(t)$	1	1

Let's derive the state table

Present state	Next state		Output z
	w = 0	w = 1	
A			0
B			0
C			0
D			1

Present state y_2y_1	Flip-flop inputs		Output z
	w = 0	w = 1	
	T_2D_1	T_2D_1	
00	00	01	0
01	00	10	0
10	10	01	0
11	10	01	1

T	$Q(t+1)$	D	$Q(t+1)$
0	0	0	0
1	$\bar{Q}(t)$	1	1

Let's derive the state table

Present state	Next state		Output z
	w = 0	w = 1	
A			0
B			0
C			0
D			1

Present state y_2y_1	Flip-flop inputs		Output z
	w = 0	w = 1	
	T_2D_1	T_2D_1	
00	00	01	0
01	00	10	0
10	10	01	0
11	10	01	1

T	$Q(t+1)$	D	$Q(t+1)$
0	0	0	0
1	$\bar{Q}(t)$	1	1

Let's derive the state table

Present state	Next state		Output z
	w = 0	w = 1	
A	A		0
B			0
C			0
D			1

Present state y_2y_1	Flip-flop inputs		Output z
	w = 0	w = 1	
	T_2D_1	T_2D_1	
00	00	01	0
01	00	10	0
10	10	01	0
11	10	01	1

Note that A = 00

T	$Q(t+1)$	D	$Q(t+1)$
0	0	0	0
1	$\bar{Q}(t)$	1	1

Let's derive the state table

Present state	Next state		Output z
	w = 0	w = 1	
A	A		0
B			0
C		?	0
D			1

Present state y_2y_1	Flip-flop inputs		Output z
	w = 0	w = 1	
	T_2D_1	T_2D_1	
00	00	01	0
01	00	10	0
10	10	01	0
11	10	01	1

What should we do here?

T	$Q(t+1)$	D	$Q(t+1)$
0	$Q(t)$	0	0
1	$\overline{Q(t)}$	1	1

Let's derive the state table

Present state	Next state		Output z
	w = 0	w = 1	
A	A		0
B			0
C			0
D			1

Present state y_2y_1	Flip-flop inputs		Output z
	w = 0	w = 1	
	T_2D_1	T_2D_1	
00	00	01	0
01	00	10	0
10	10	01	0
11	10	01	1

T	$Q(t+1)$	D	$Q(t+1)$
0	$Q(t)$	0	0
1	$\overline{Q(t)}$	1	1

Let's derive the state table

Present state	Next state		Output z
	w = 0	w = 1	
A	A		0
B			0
C			0
D			1

Present state y_2y_1	Flip-flop inputs		Output z
	w = 0	w = 1	
	T_2D_1	T_2D_1	
00	00	01	0
01	00	10	0
10	10	01	0
11	10	01	1

T	$Q(t+1)$	D	$Q(t+1)$
0	$Q(t)$	0	0
1	$\overline{Q(t)}$	1	1

Let's derive the state table

Present state	Next state		Output z
	w = 0	w = 1	
A	A		0
B			0
C			0
D			1

Present state y_2y_1	Flip-flop inputs		Output z
	w = 0	w = 1	
	T_2D_1	T_2D_1	
00	00	01	0
01	00	10	0
10	10	01	0
11	10	01	1

T	$Q(t+1)$	D	$Q(t+1)$
0	$Q(t)$	0	0
1	$\bar{Q}(t)$	1	1

Let's derive the state table

Present state	Next state		Output z
	w = 0	w = 1	
A	A		0
B			0
C			0
D			1

Present state y_2y_1	Flip-flop inputs		Output z
	w = 0	w = 1	
	T_2D_1	T_2D_1	
00	00	01	0
01	00	10	0
10	10	01	0
11	10	01	1

T	$Q(t+1)$	D	$Q(t+1)$
0	1	0	0
1	$\bar{Q}(t)$	1	1

Let's derive the state table

Present state	Next state		Output z
	w = 0	w = 1	
A	A		0
B			0
C			0
D			1

Present state y_2y_1	Flip-flop inputs		Output z
	w = 0	w = 1	
	T_2D_1	T_2D_1	
00	00	01	0
01	00	10	0
10	10	01	0
11	10	01	1

T	$Q(t+1)$	D	$Q(t+1)$
0	1	0	0
1	$\bar{Q}(t)$	1	1

Let's derive the state table

Present state	Next state		Output z
	w = 0	w = 1	
A	A		0
B			0
C			0
D			1

Present state y_2y_1	Flip-flop inputs		Output z
	w = 0	w = 1	
	T_2D_1	T_2D_1	
00	00	01	0
01	00	10	0
10	10	01	0
11	10	01	1

T	$Q(t+1)$	D	$Q(t+1)$
0	1	0	0
1	$\bar{Q}(t)$	1	1

Let's derive the state table

Present state	Next state		Output z
	w = 0	w = 1	
A	A		0
B			0
C		D	0
D			1

Present state y_2y_1	Flip-flop inputs		Output z
	w = 0	w = 1	
	T_2D_1	T_2D_1	
00	00	01	0
01	00	10	0
10	10	01	0
11	10	01	1

Note that D = 11

T	$Q(t+1)$	D	$Q(t+1)$
0	1	0	0
1	$\bar{Q}(t)$	1	1

Let's derive the state table

Present state	Next state		Output z
	w = 0	w = 1	
A	A	B	0
B	A	C	0
C	A	D	0
D	A	D	1

Present state y_2y_1	Flip-flop inputs		Output z
	w = 0	w = 1	
	T_2D_1	T_2D_1	
00	00	01	0
01	00	10	0
10	10	01	0
11	10	01	1

T	$Q(t+1)$	D	$Q(t+1)$
0	$Q(t)$	0	0
1	$\overline{Q(t)}$	1	1

The two tables for the initial circuit

Present state	Next state		Output z
	w = 0	w = 1	
A	A	B	0
B	A	C	0
C	A	D	0
D	A	D	1

State table

Present state y_2y_1	Flip-flop inputs		Output z
	w = 0	w = 1	
	T_2D_1	T_2D_1	
00	00	01	0
01	00	10	0
10	10	01	0
11	10	01	1

Excitation table

[Figure 6.75b from the textbook]

[Figure 6.80 from the textbook]

The state diagram

Present state	Next state		Output z
	w = 0	w = 1	
A	A	B	0
B	A	C	0
C	A	D	0
D	A	D	1

State table

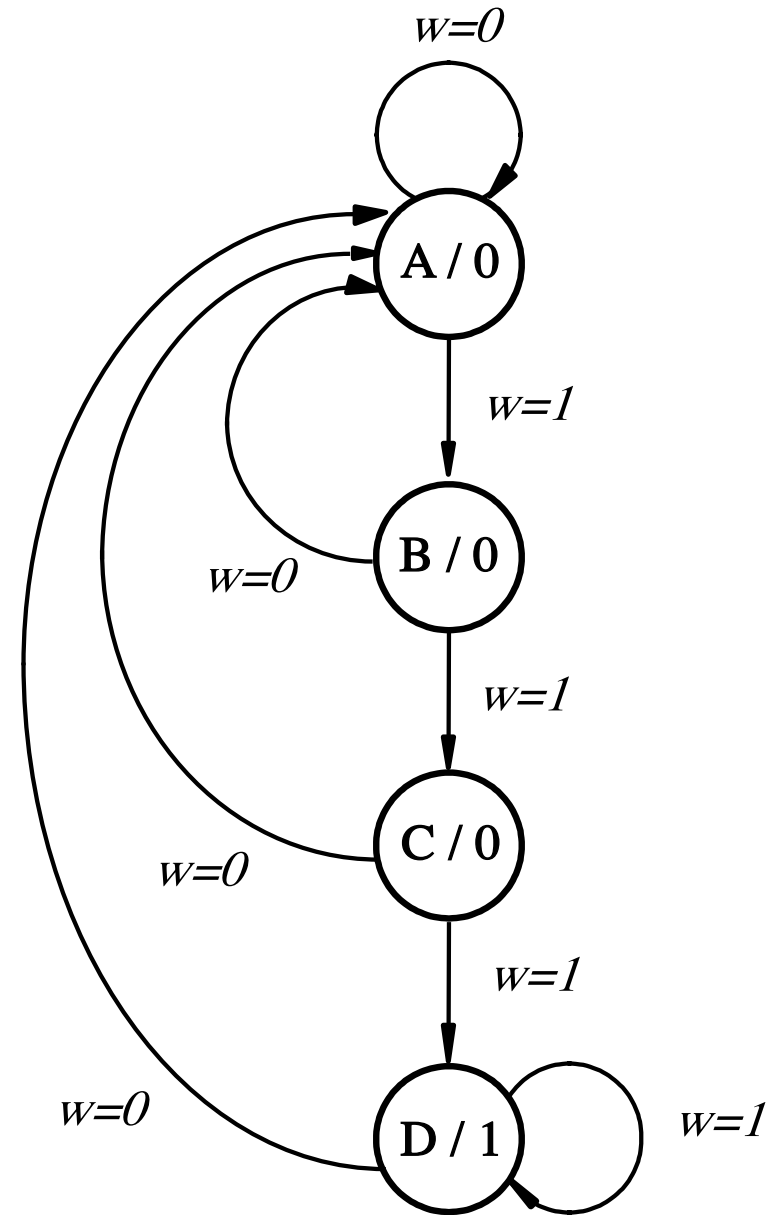

State diagram

The state diagram

Thus, this FSM is identical to the ones in the previous examples, even though the circuit uses one D and one T flip-flop.

Present state	Next state		Output z
	w = 0	w = 1	
A	A	B	0
B	A	C	0
C	A	D	0
D	A	D	1

State table

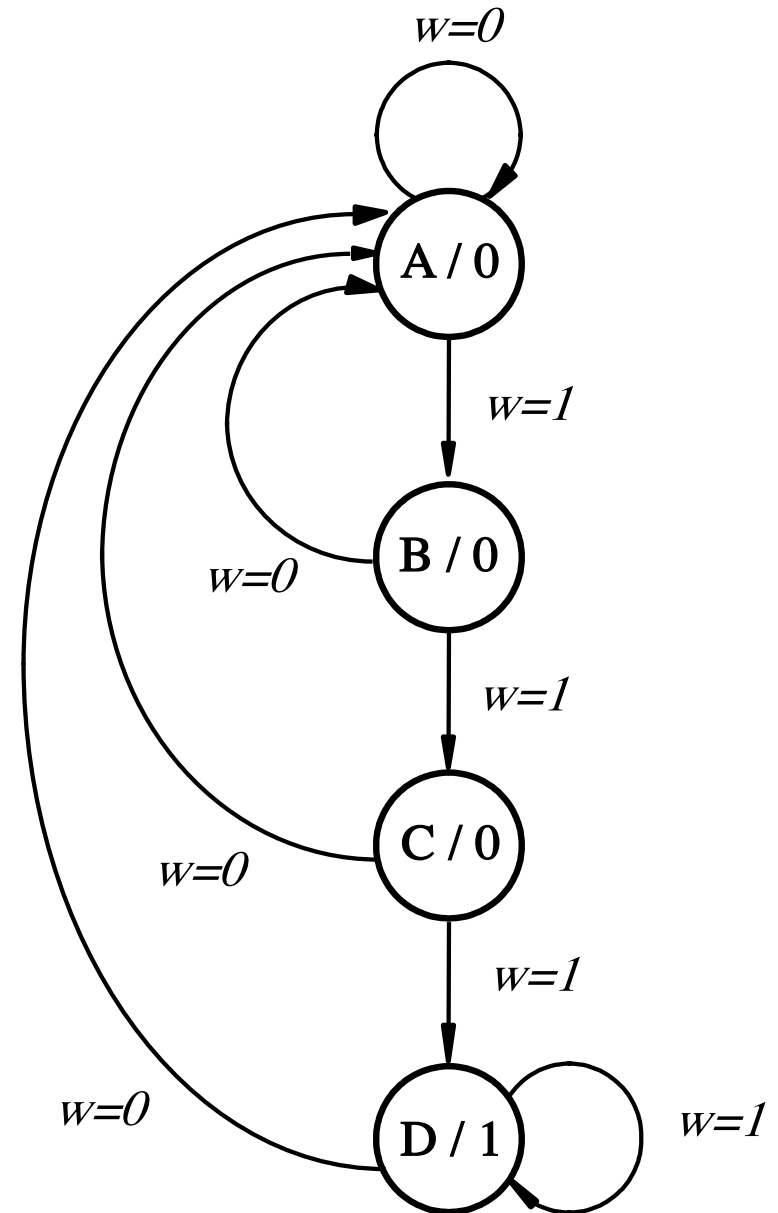

State diagram

Questions?

THE END