



CprE 281: Digital Logic

Instructor: Alexander Stoytchev

<http://www.ece.iastate.edu/~alexs/classes/>

Registers and Counters

CprE 281: Digital Logic
Iowa State University, Ames, IA
Copyright © Alexander Stoytchev

Administrative Stuff

- **The second midterm is this Friday.**
- **Homework 8 is due today.**
- **Homework 9 is out. It is due on Mon Nov 5.**
- **No HW due next Monday**

Administrative Stuff

- **Midterm Exam #2**
- **When: Friday October 26 @ 4pm.**
- **Where: This classroom**
- **What: Chapters 1, 2, 3, 4 and 5.1-5.8**
- **The exam will be open book and open notes (you can bring up to 3 pages of handwritten notes).**

Registers

Register (Definition)

An n-bit structure consisting of flip-flops

Parallel-Access Register

1-Bit Parallel-Access Register

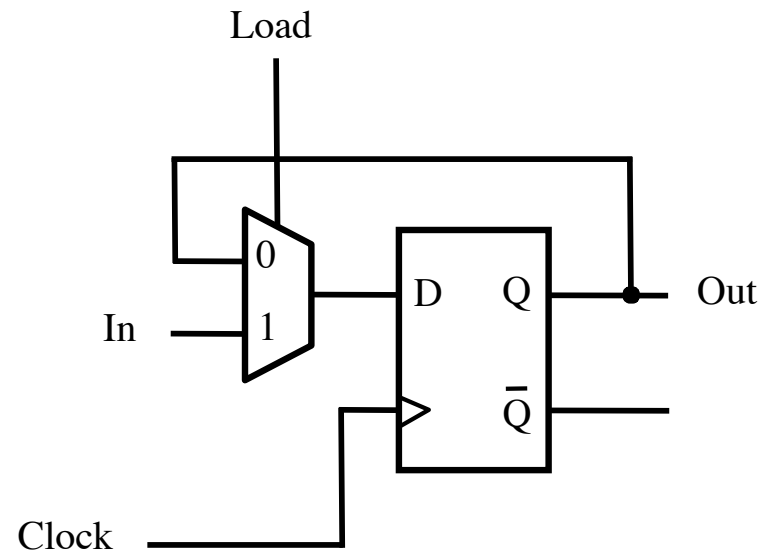

1-Bit Parallel-Access Register

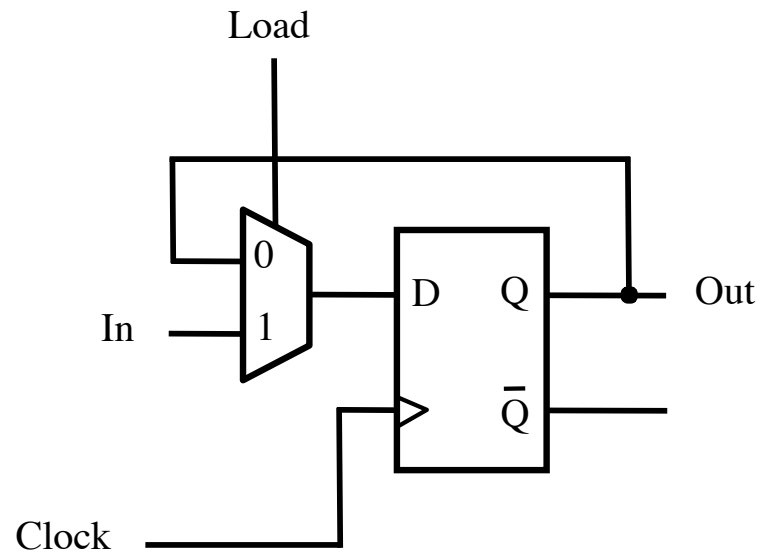

The 2-to-1 multiplexer is used to select whether to load a new value into the D flip-flop or to retain the old value.

The output of this circuit is the Q output of the flip-flop.

1-Bit Parallel-Access Register

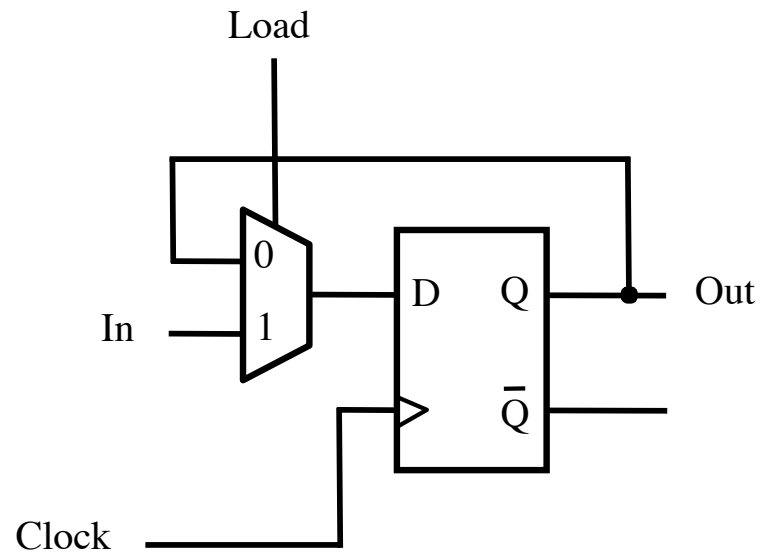

If Load = 0, then retain the old value.

If Load = 1, then load the new value from In.

2-Bit Parallel-Access Register

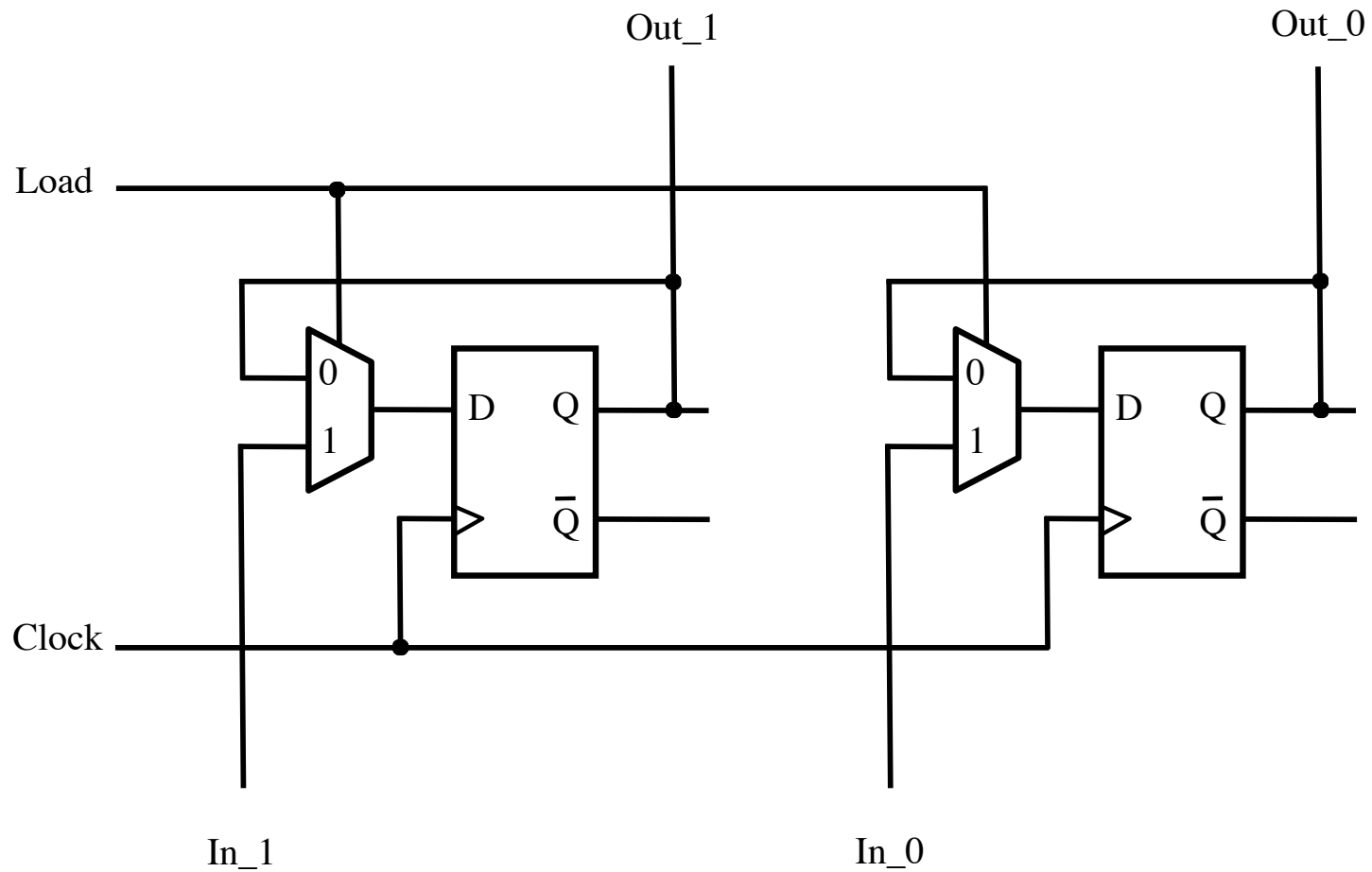

2-Bit Parallel-Access Register

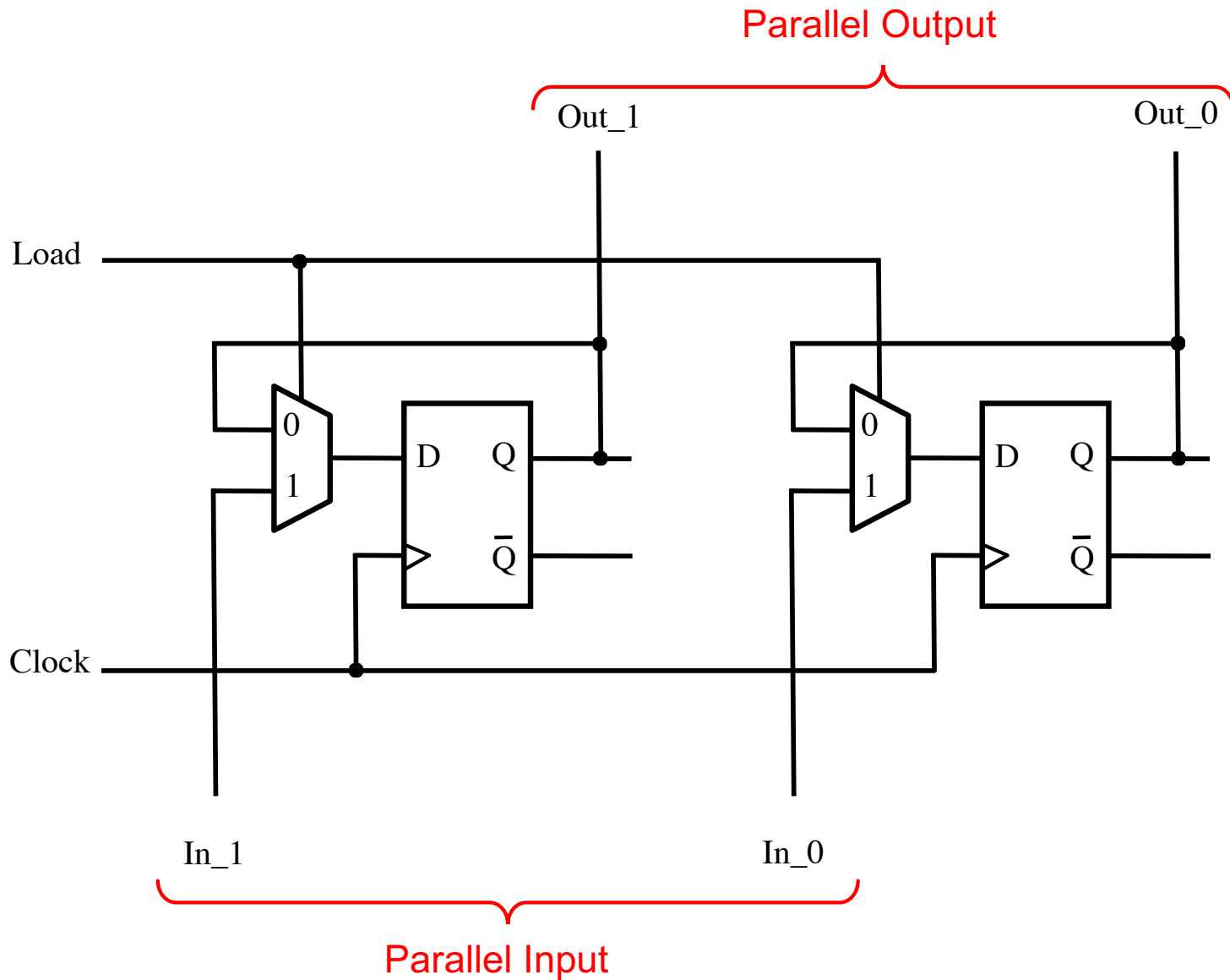

3-Bit Parallel-Access Register

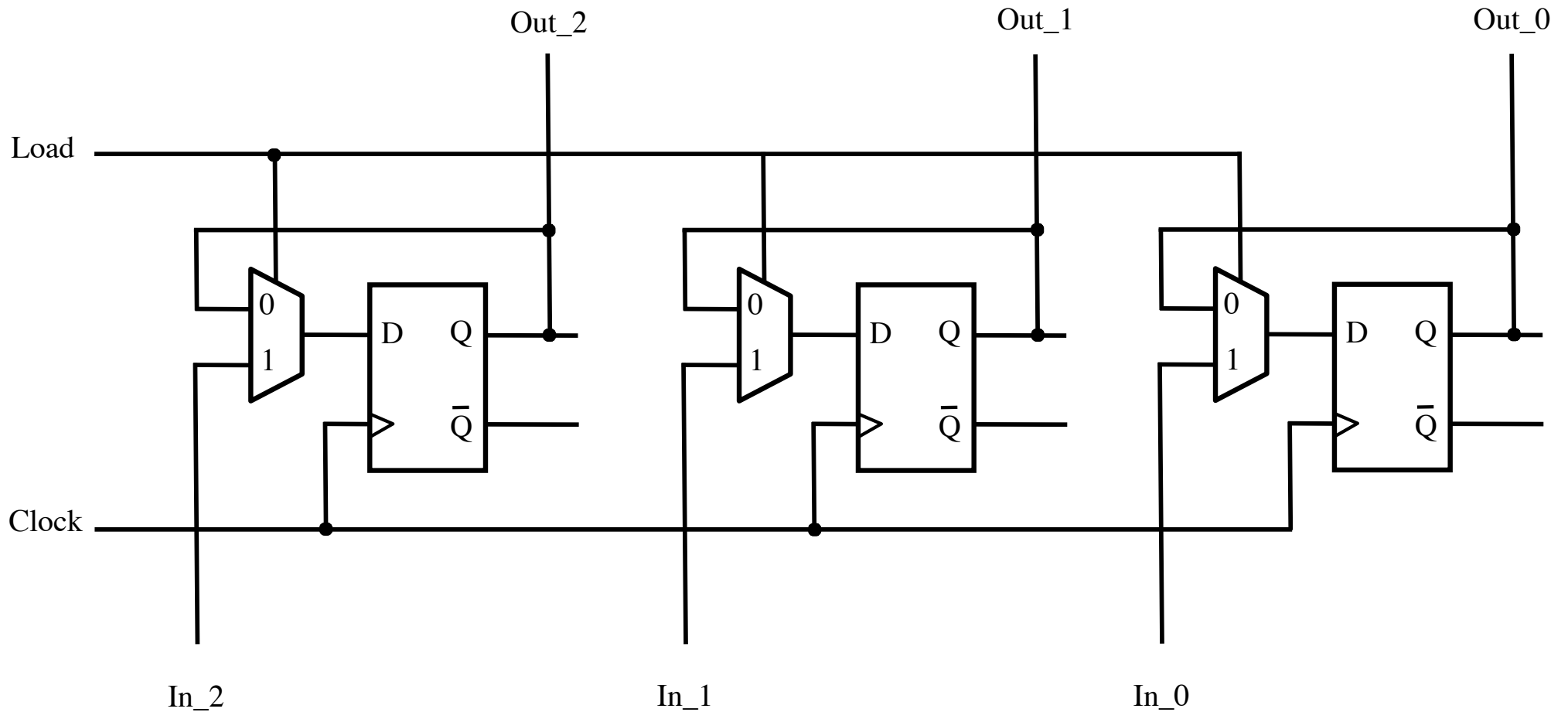

Notice that all flip-flops are on the same clock cycle.

3-Bit Parallel-Access Register

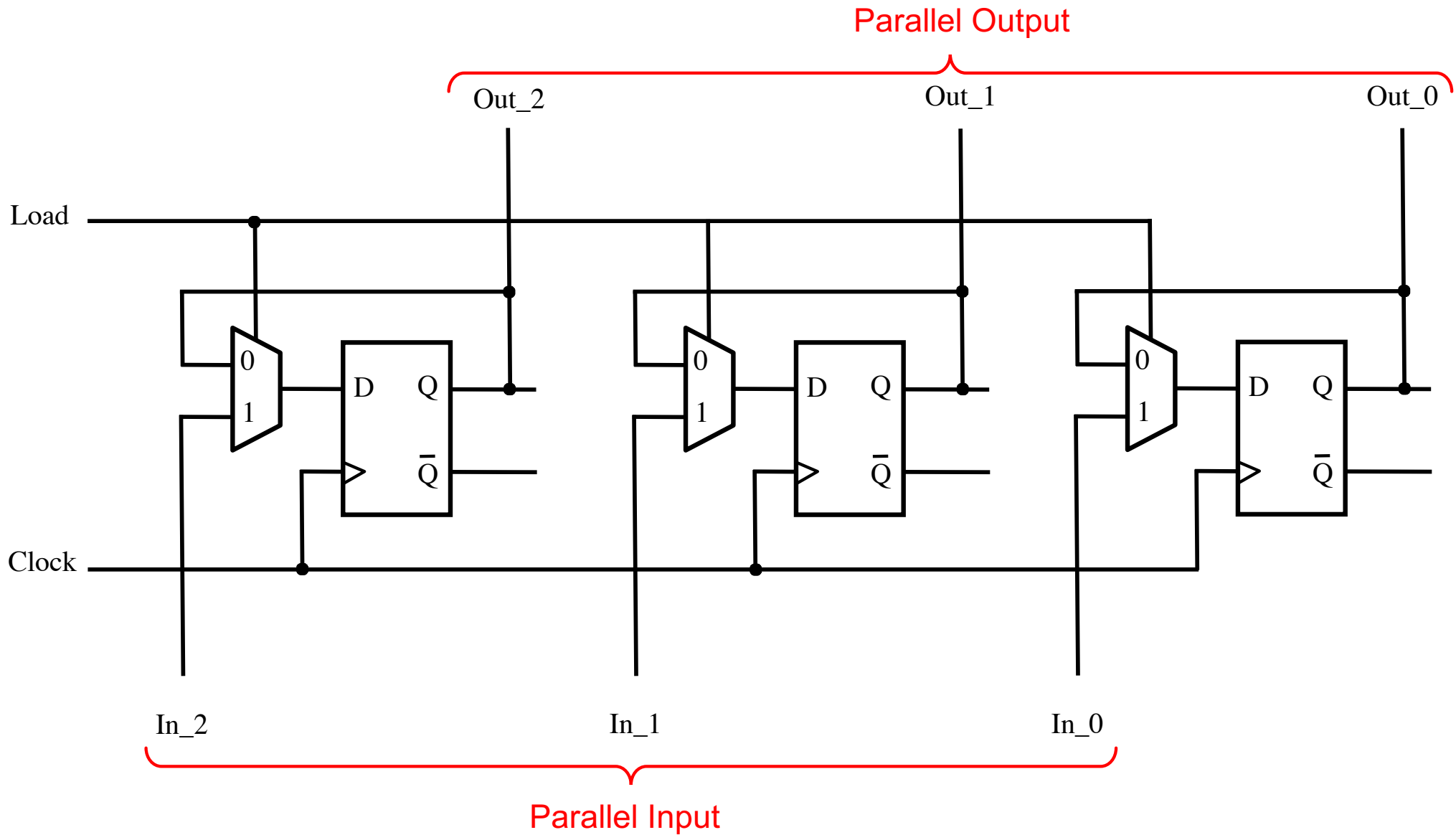

4-Bit Parallel-Access Register

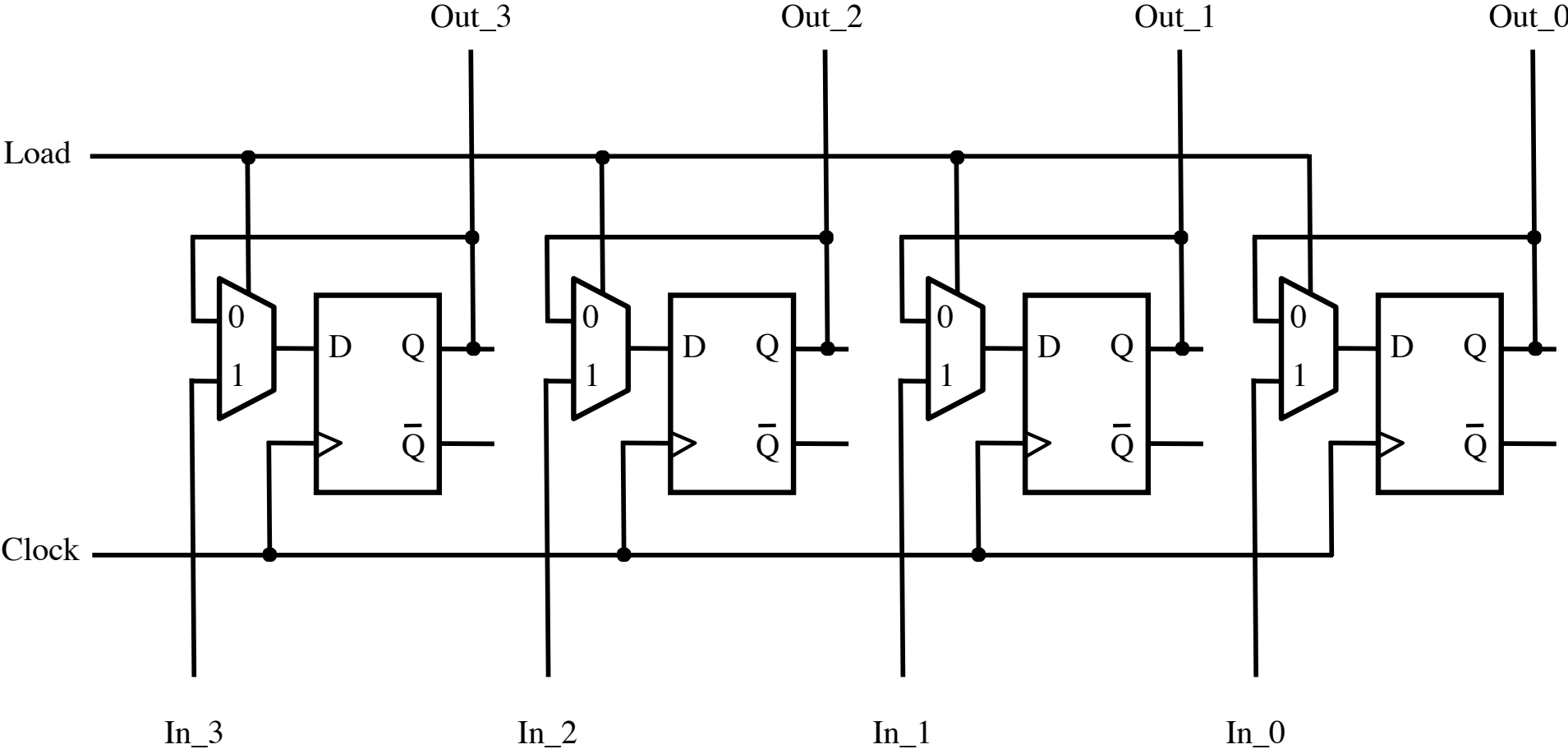

4-Bit Parallel-Access Register

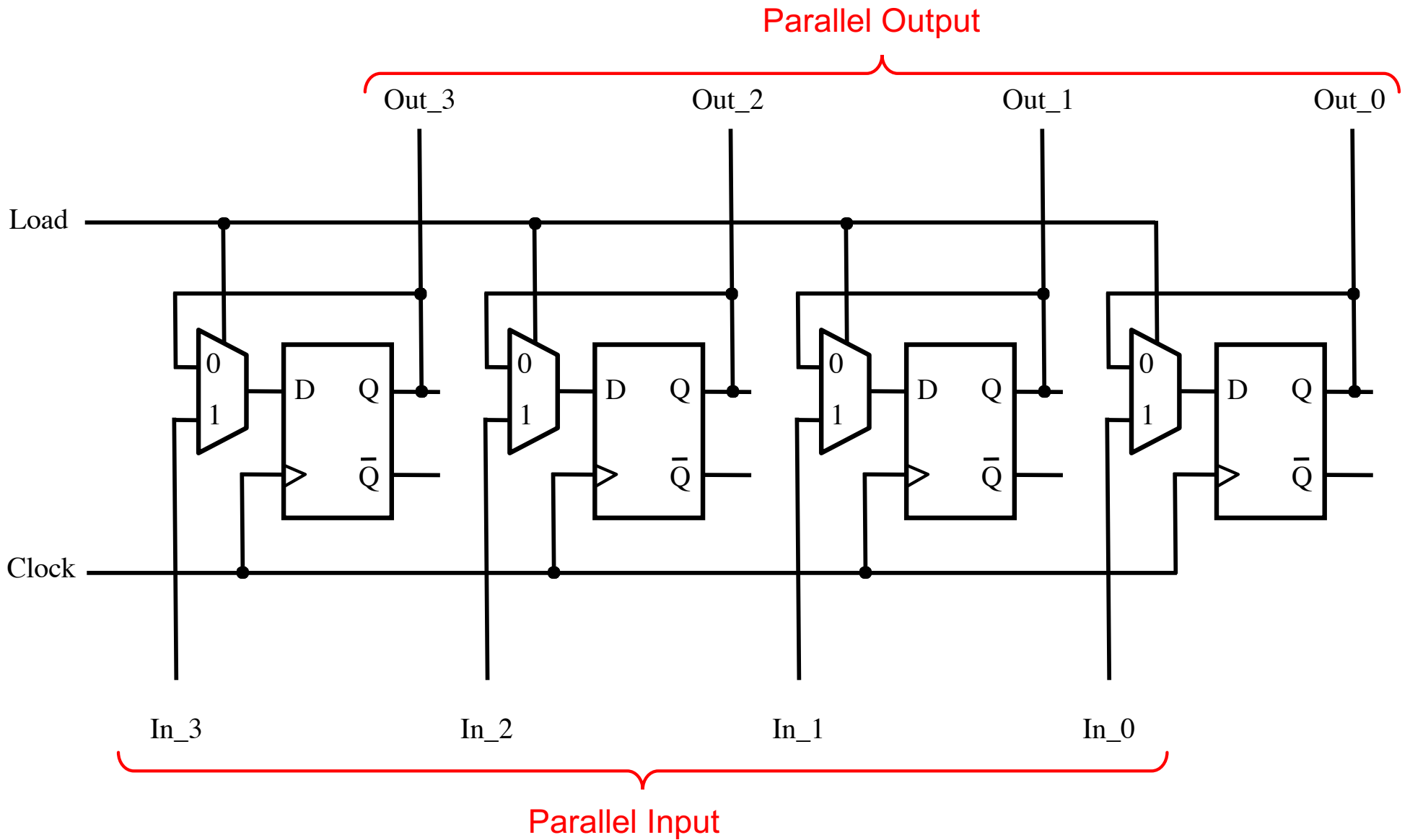

Shift Register

A simple shift register

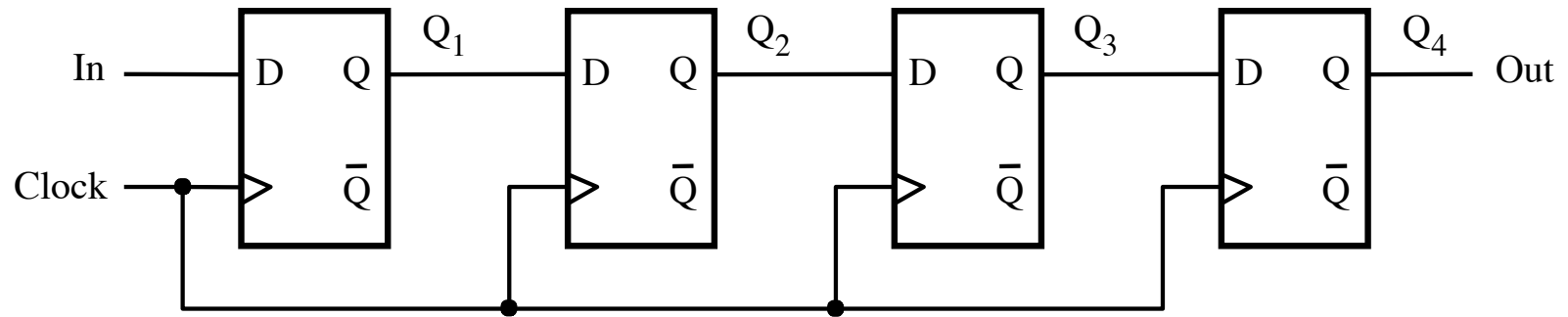

A simple shift register

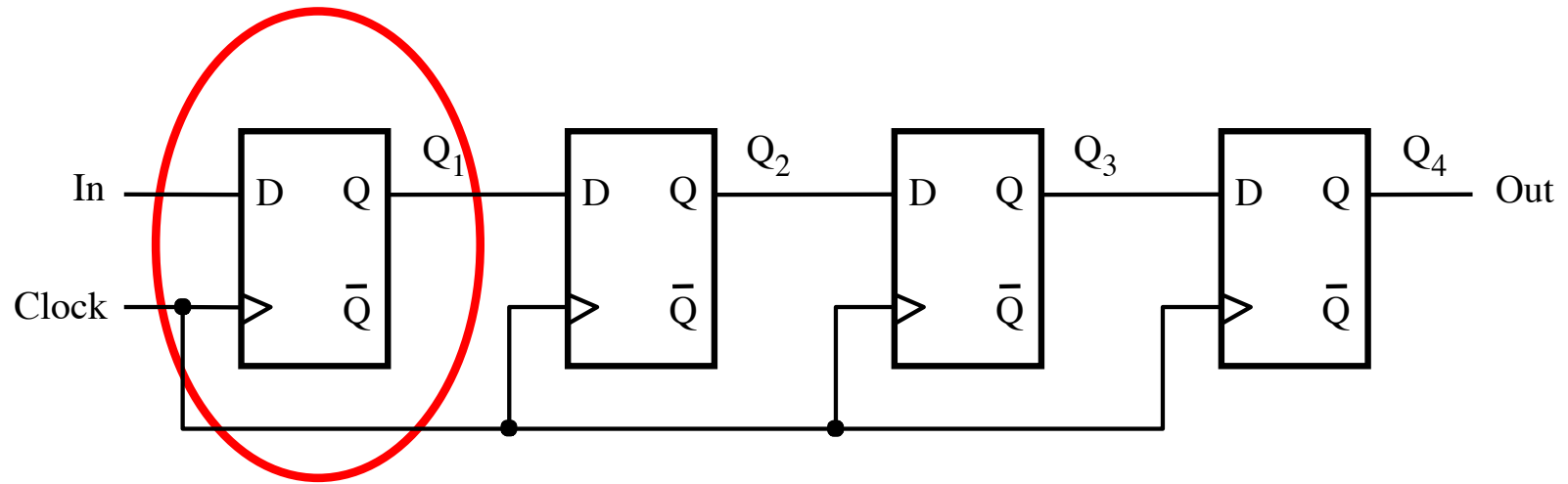

Positive-edge-triggered
D Flip-Flop

A simple shift register

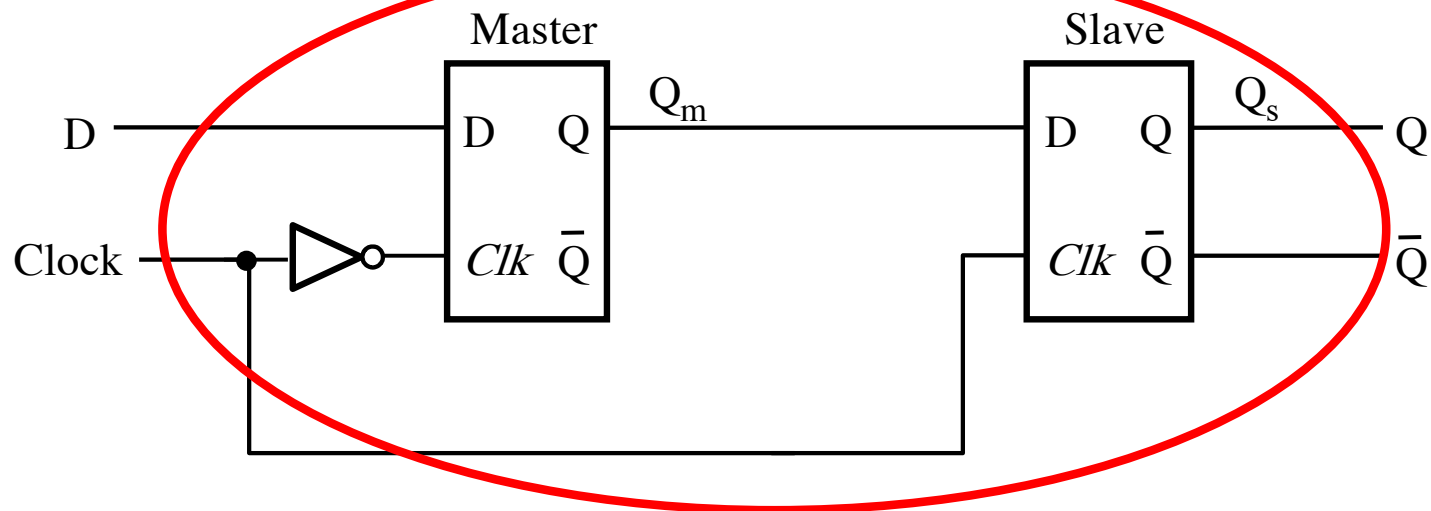
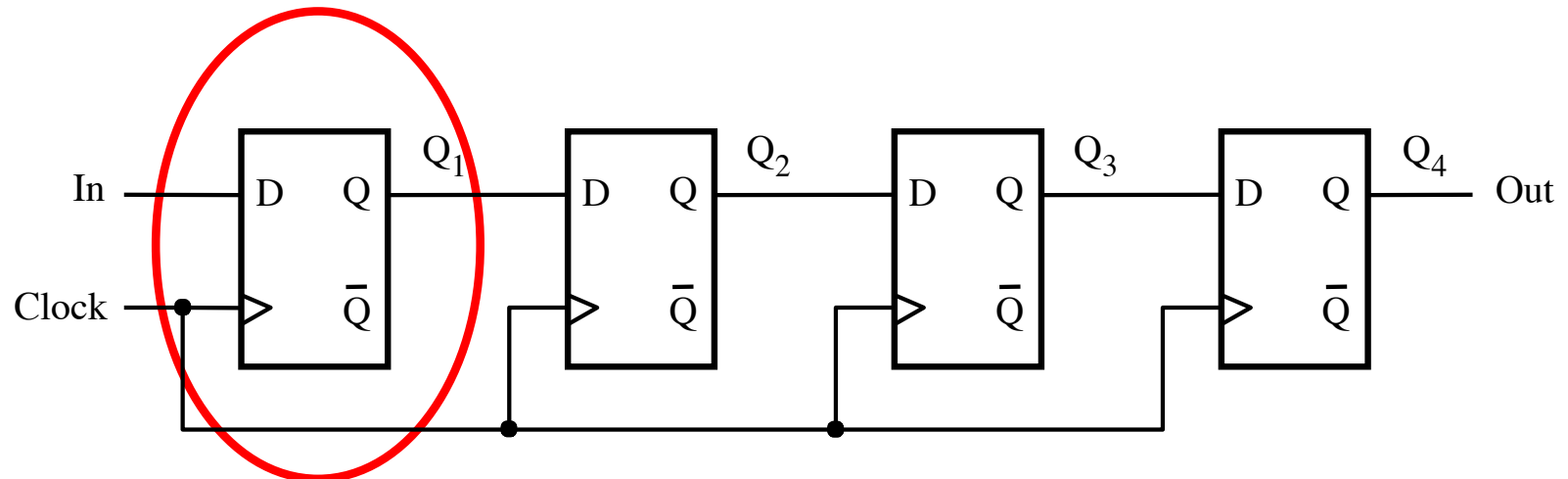

A simple shift register

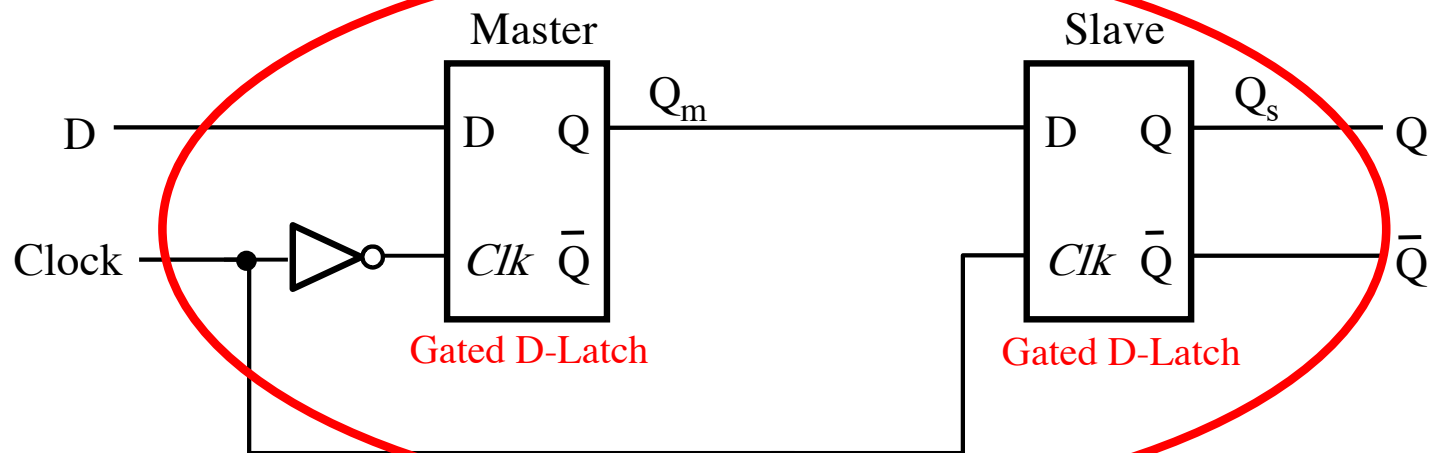
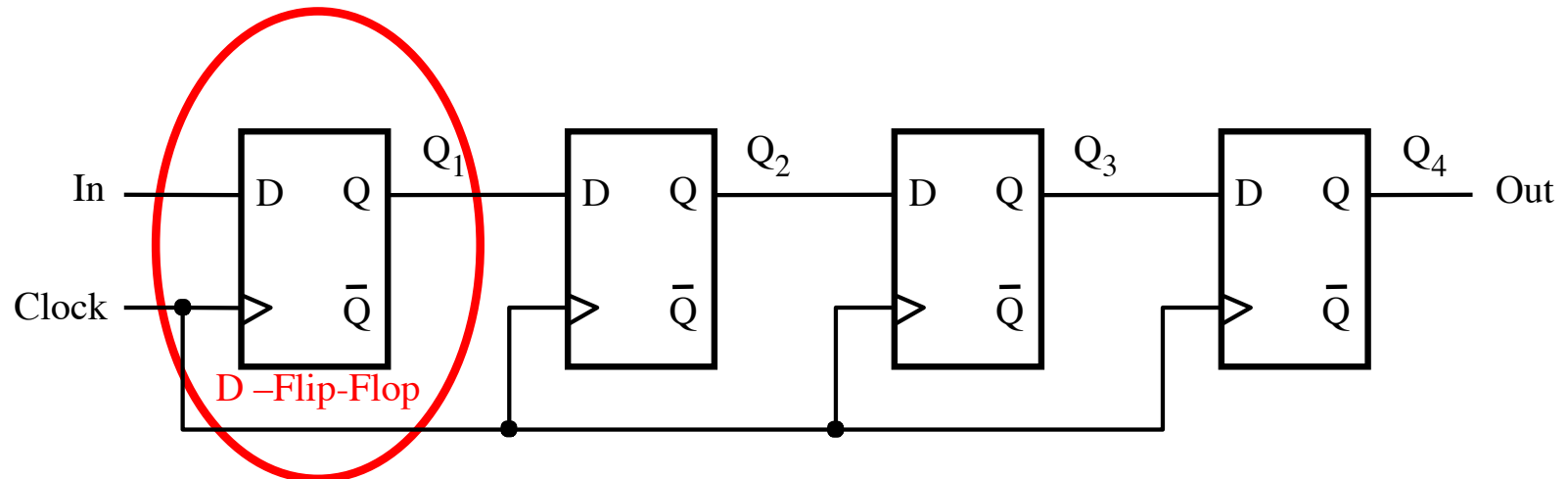

A simple shift register

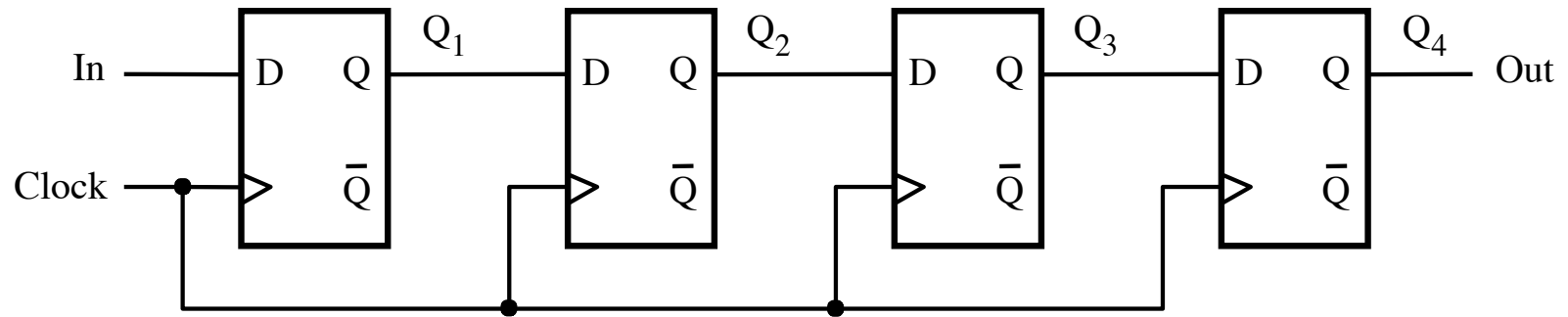

A simple shift register

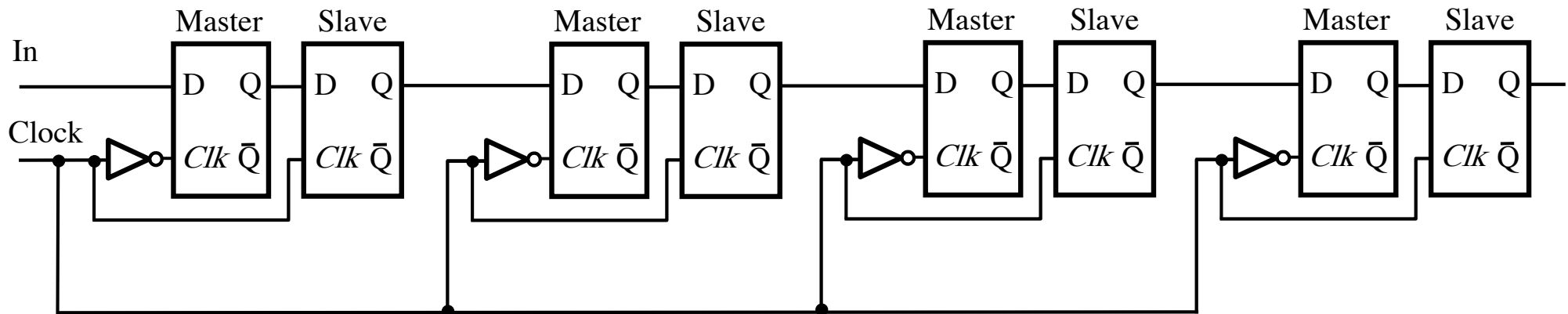
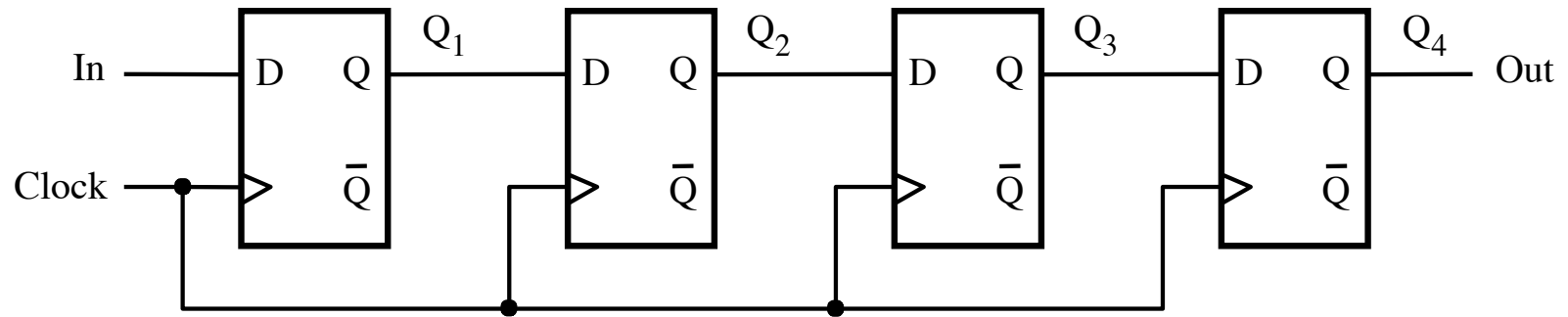

A simple shift register

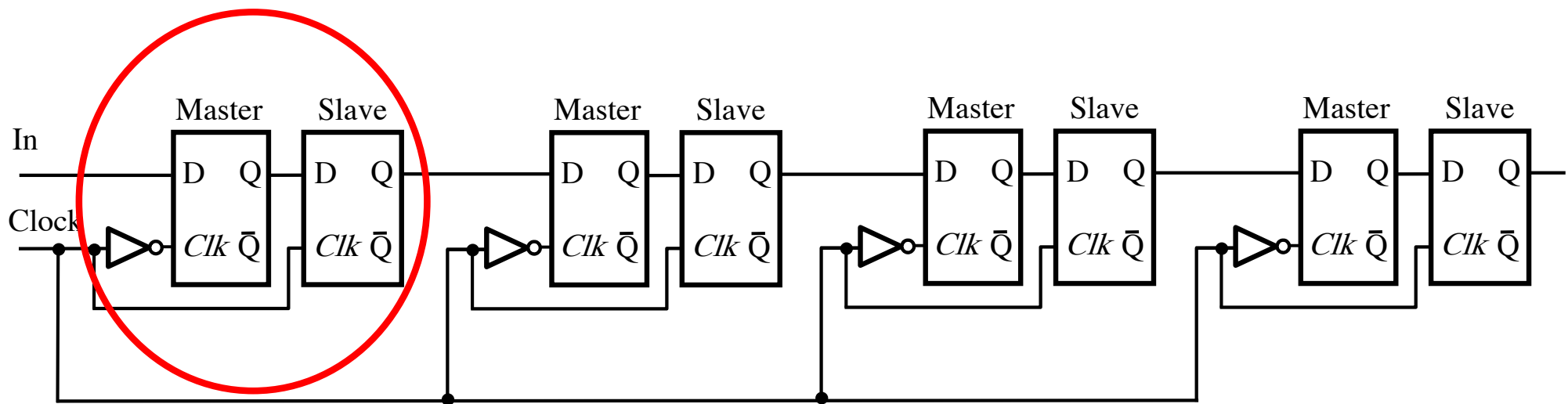
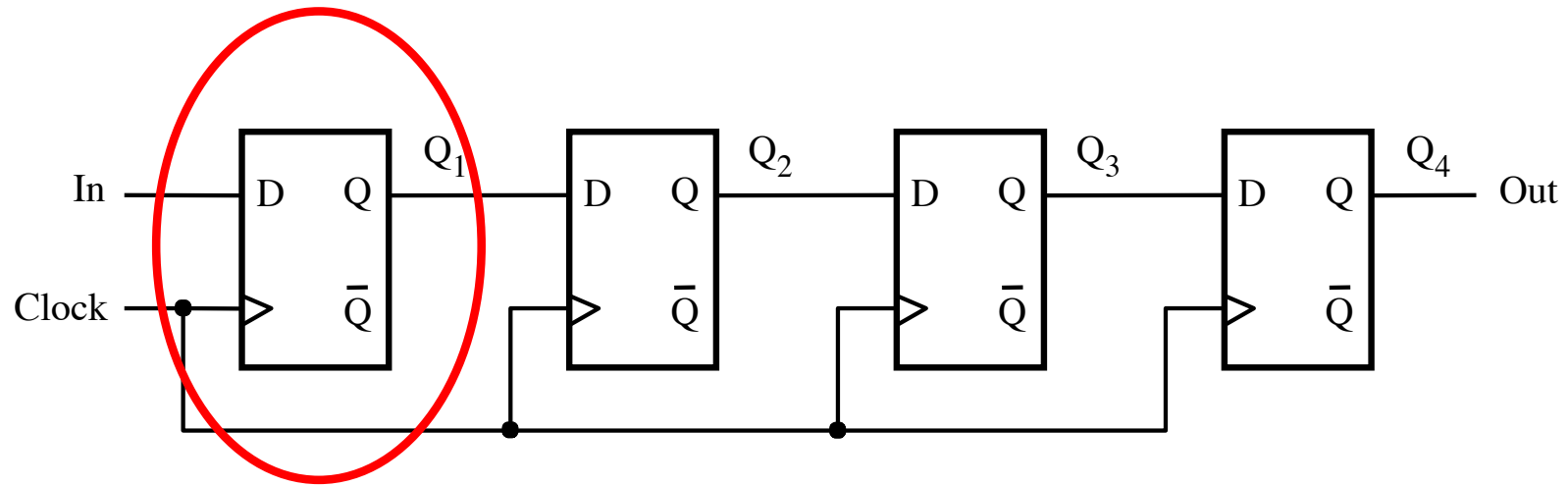

A simple shift register

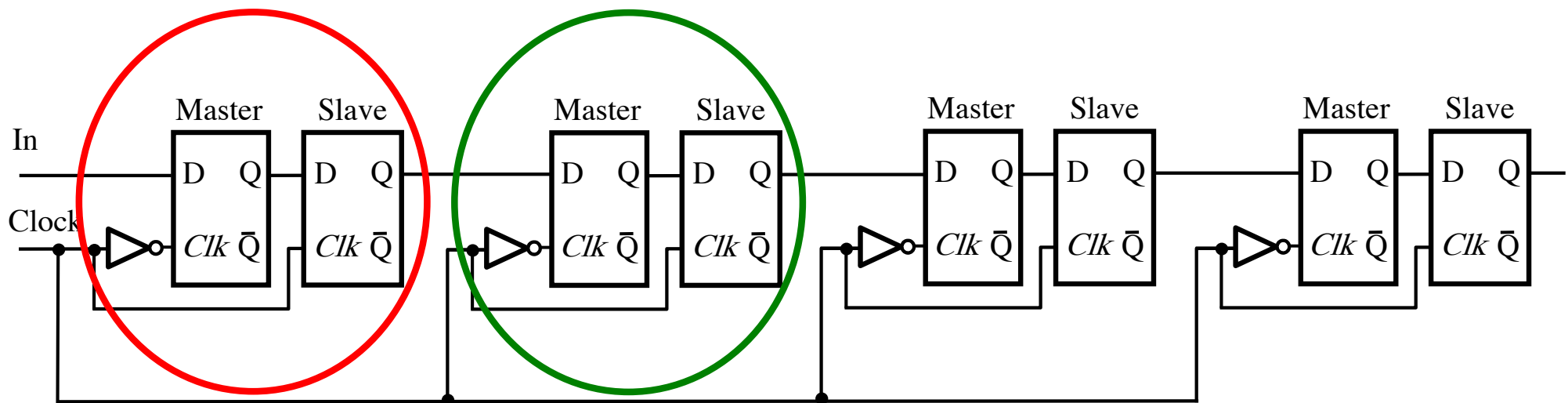
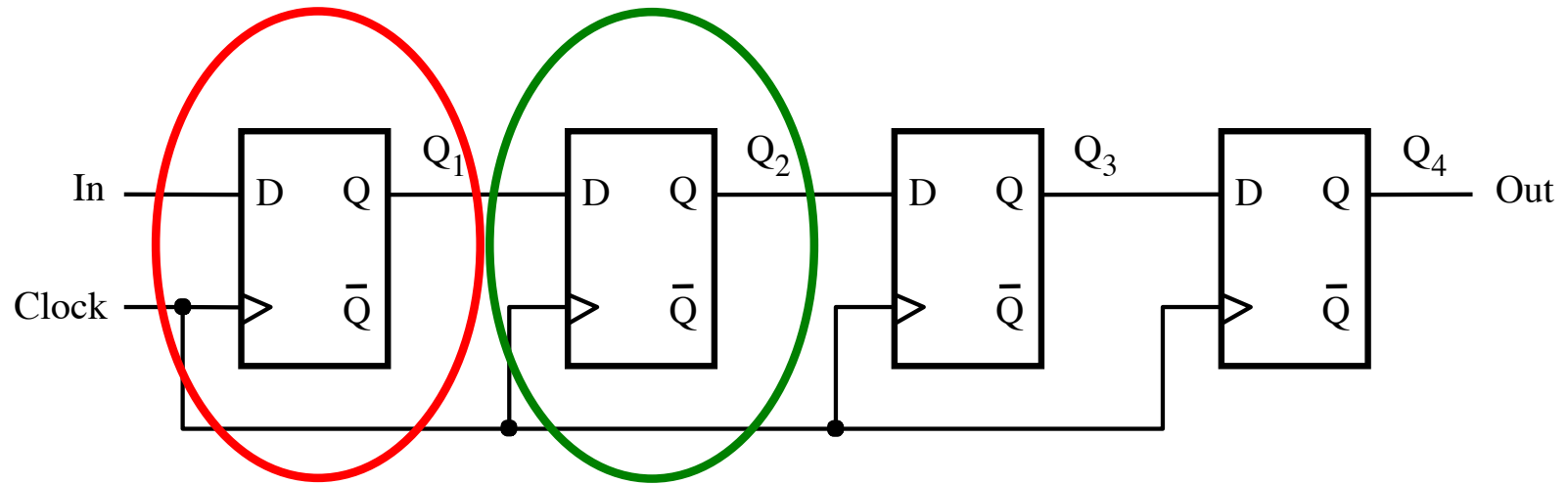

A simple shift register

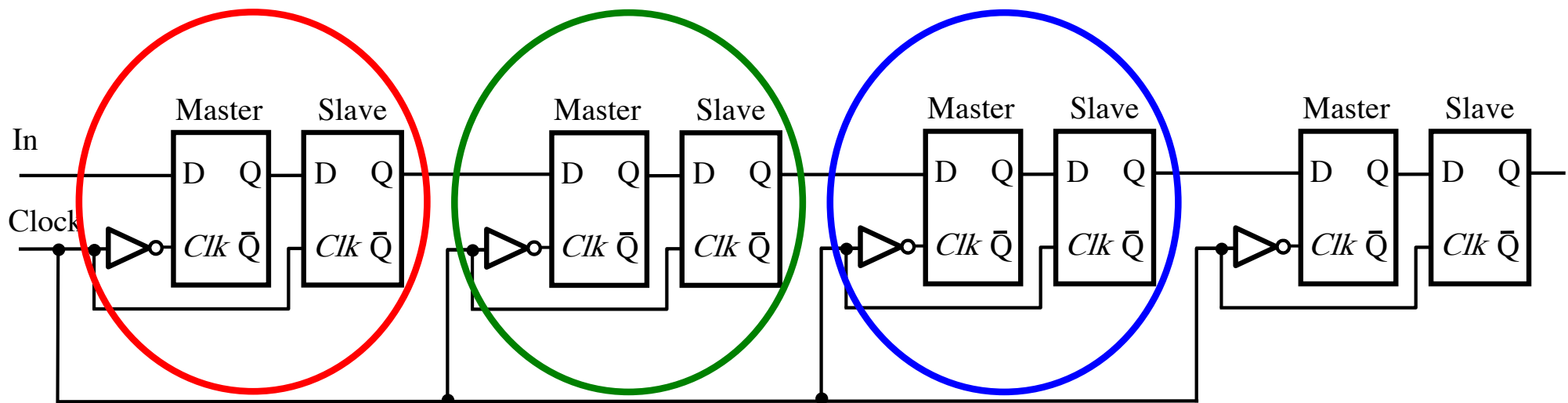
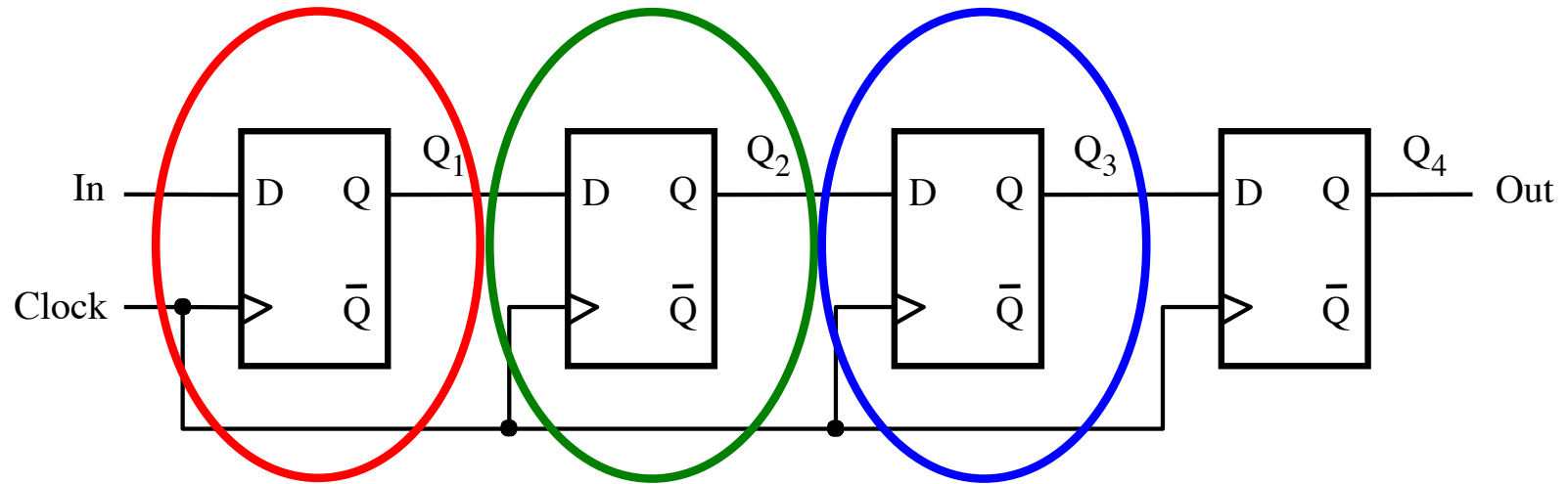

A simple shift register

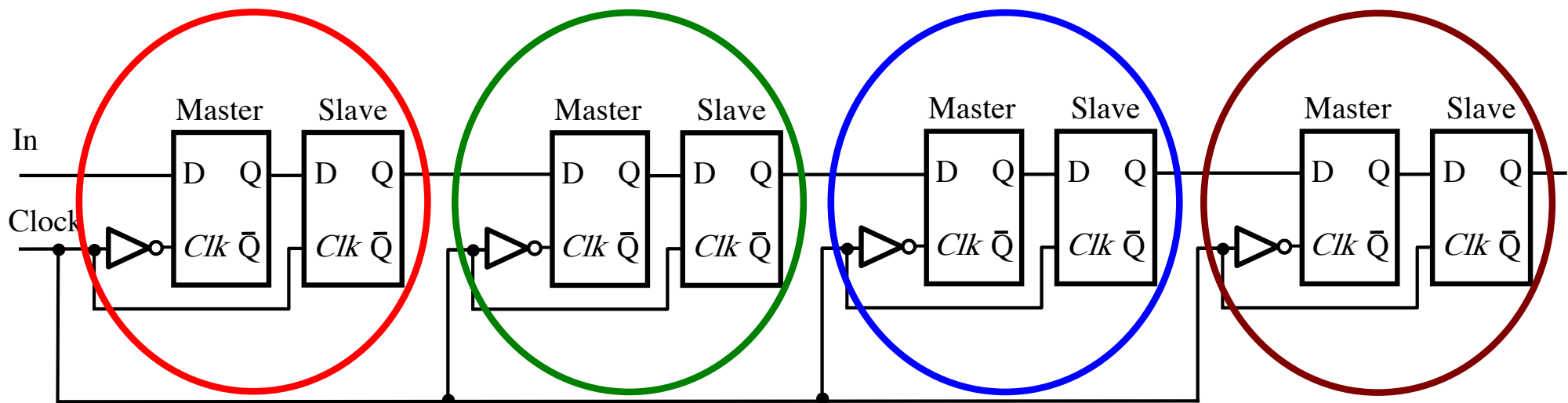
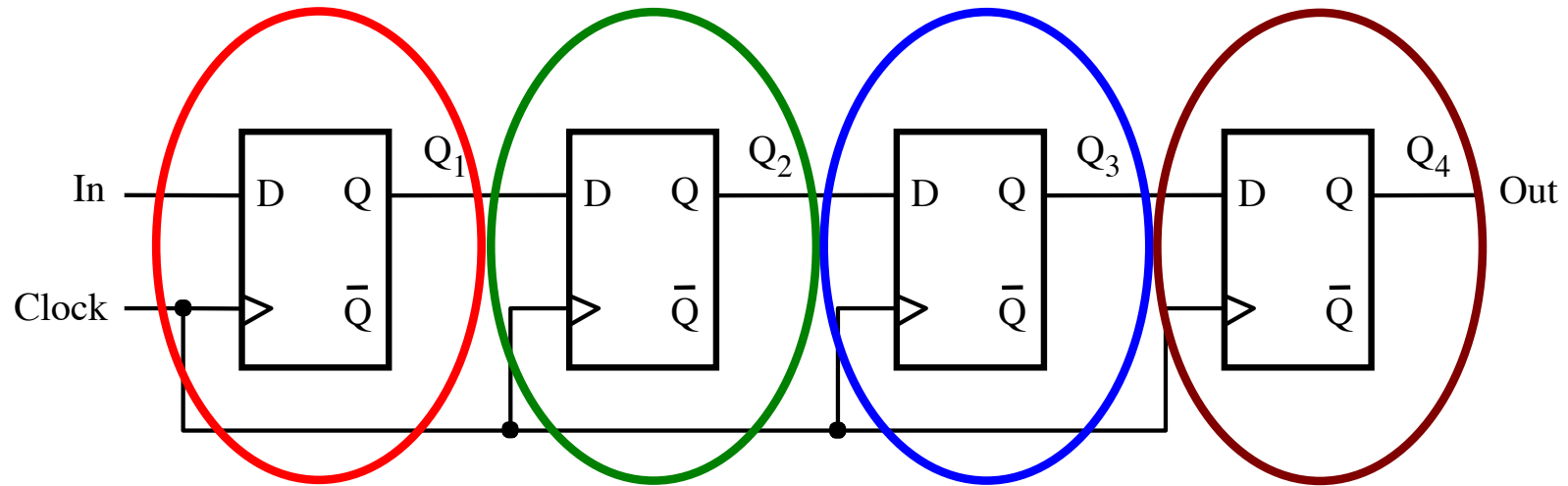

A simple shift register

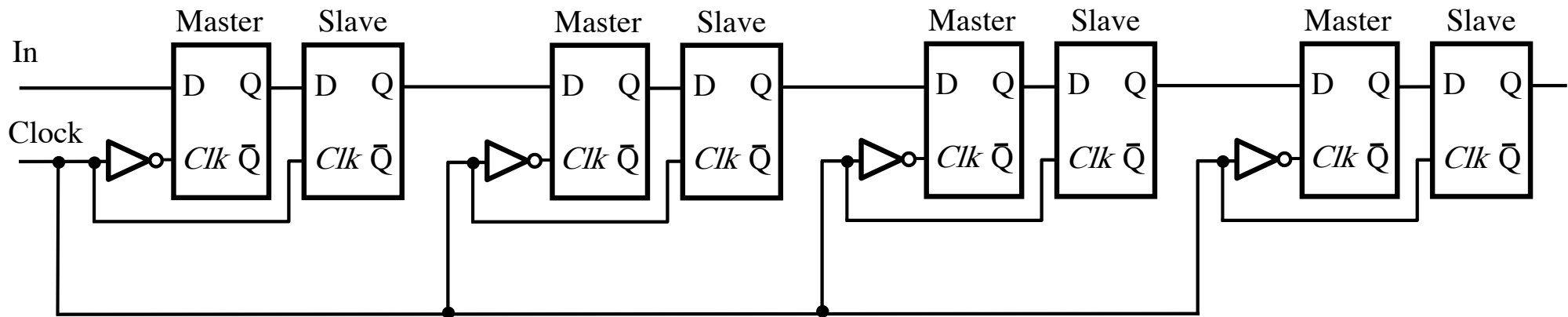

A simple shift register

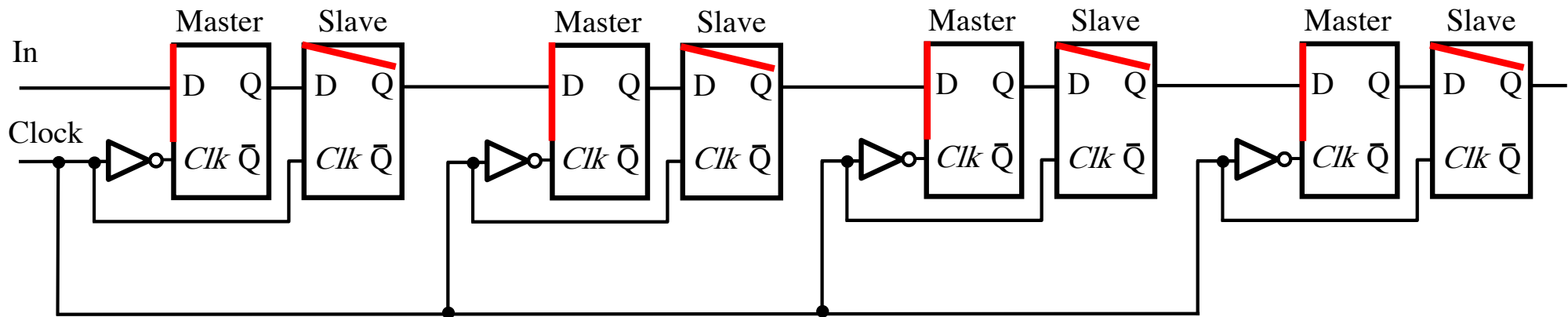

A simple shift register

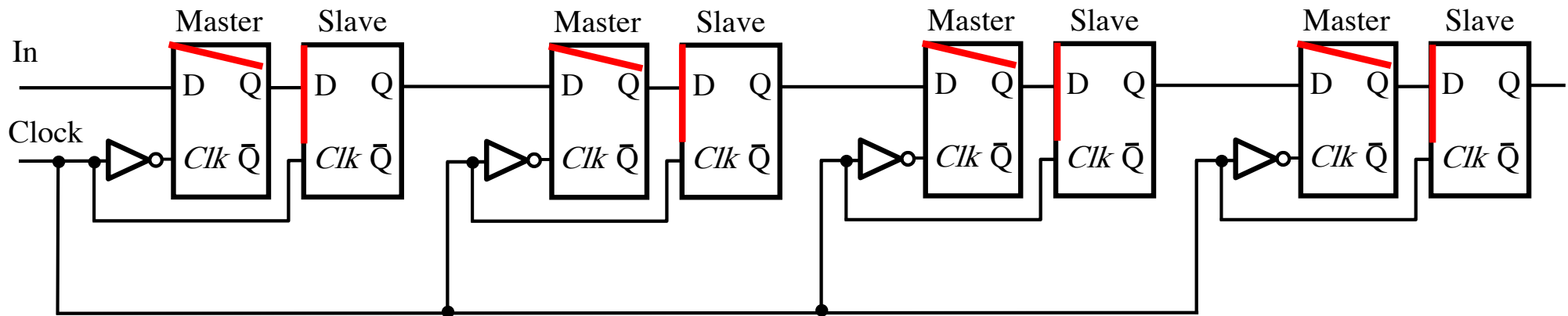

Clock



A simple shift register

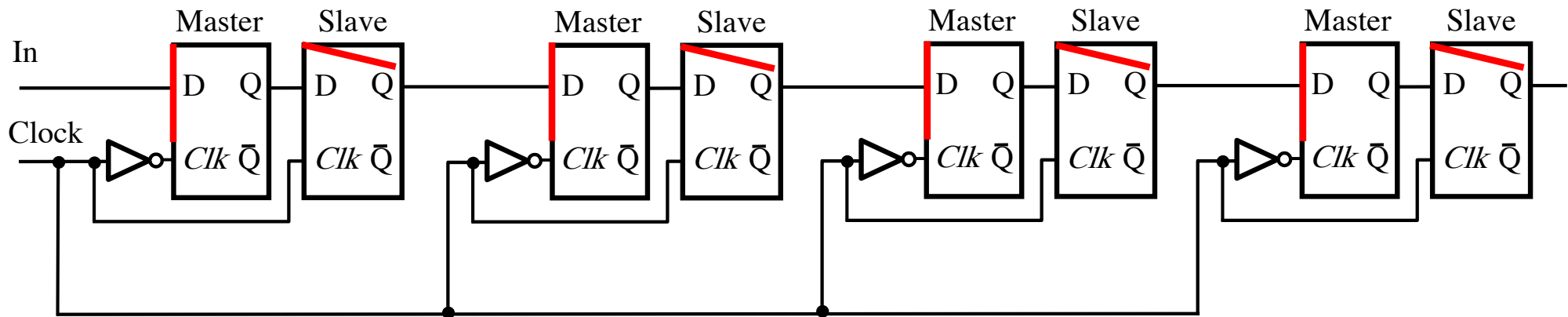

A simple shift register

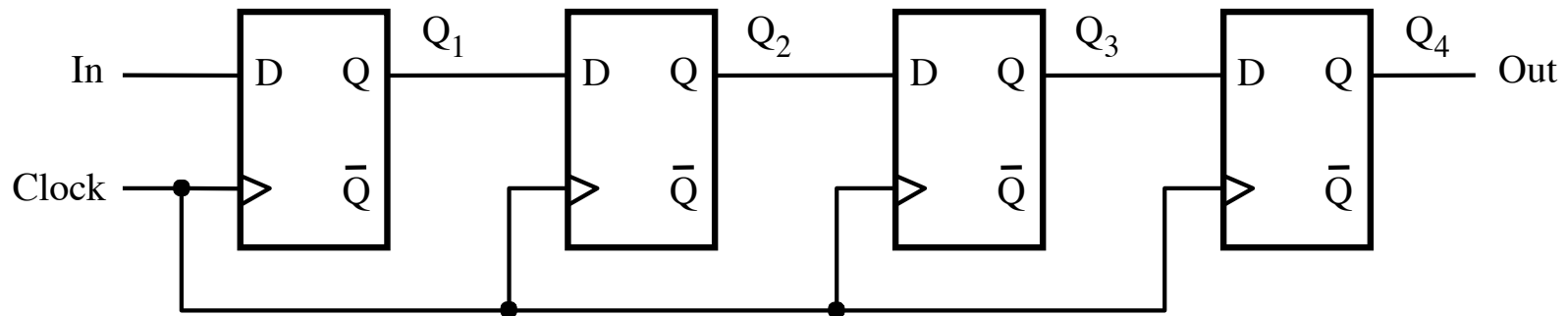

(a) Circuit

	In	Q ₁	Q ₂	Q ₃	Q ₄ = Out
t_0	1	0	0	0	0
t_1	0	1	0	0	0
t_2	1	0	1	0	0
t_3	1	1	0	1	0
t_4	1	1	1	0	1
t_5	0	1	1	1	0
t_6	0	0	1	1	1
t_7	0	0	0	1	1

(b) A sample sequence

Parallel-Access Shift Register

Parallel-access shift register

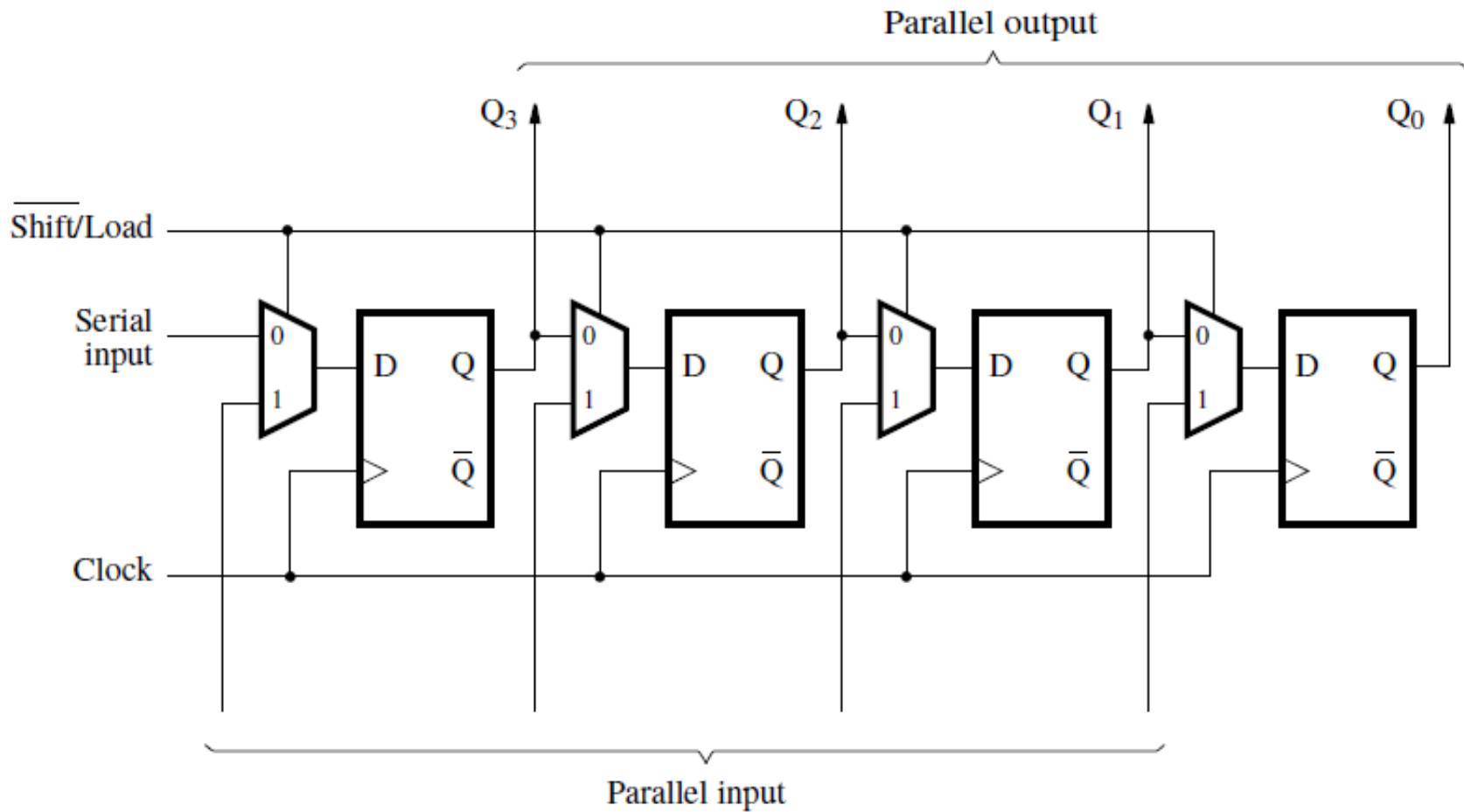

Parallel-access shift register

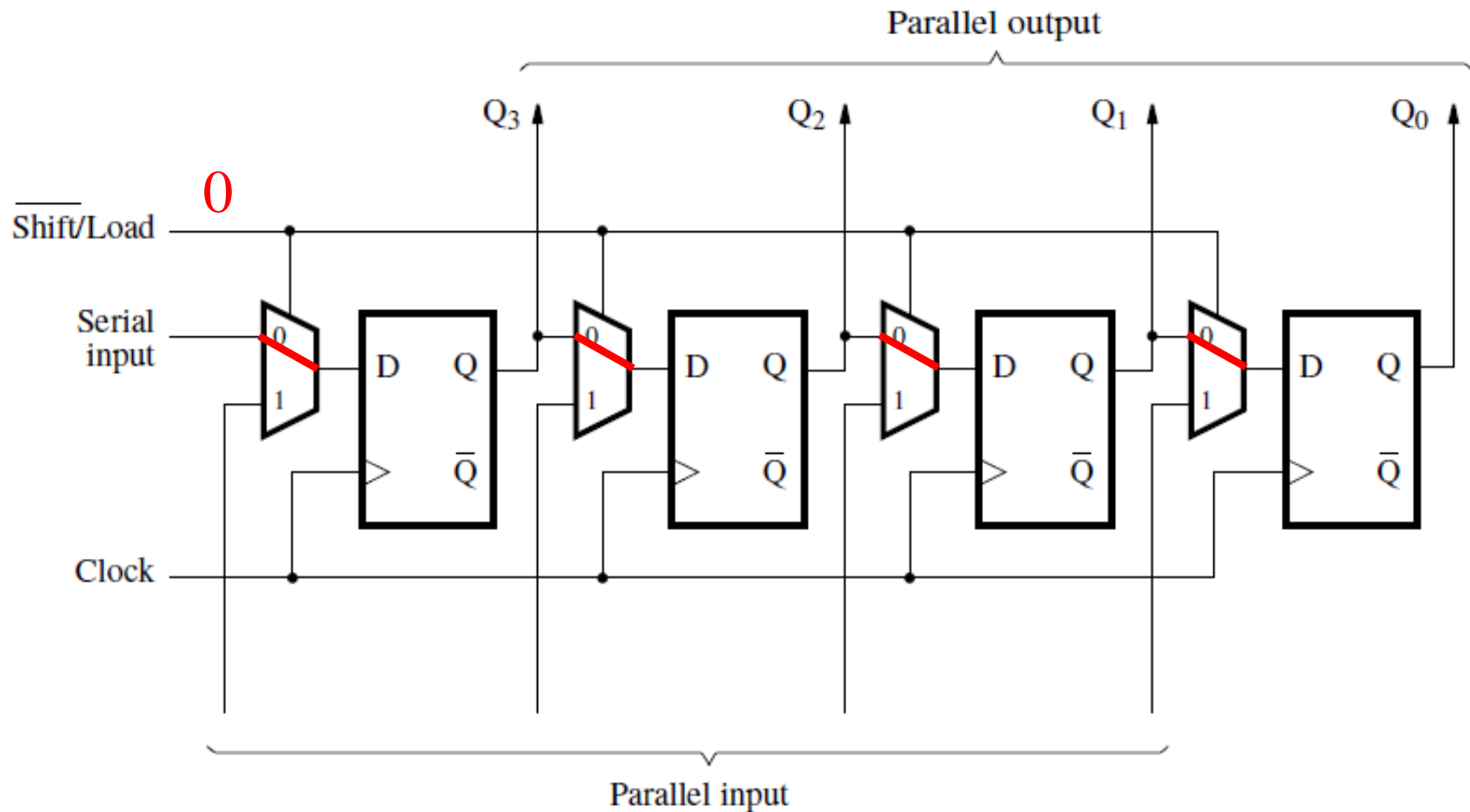

When Load=0, this behaves like a shift register.

Parallel-access shift register

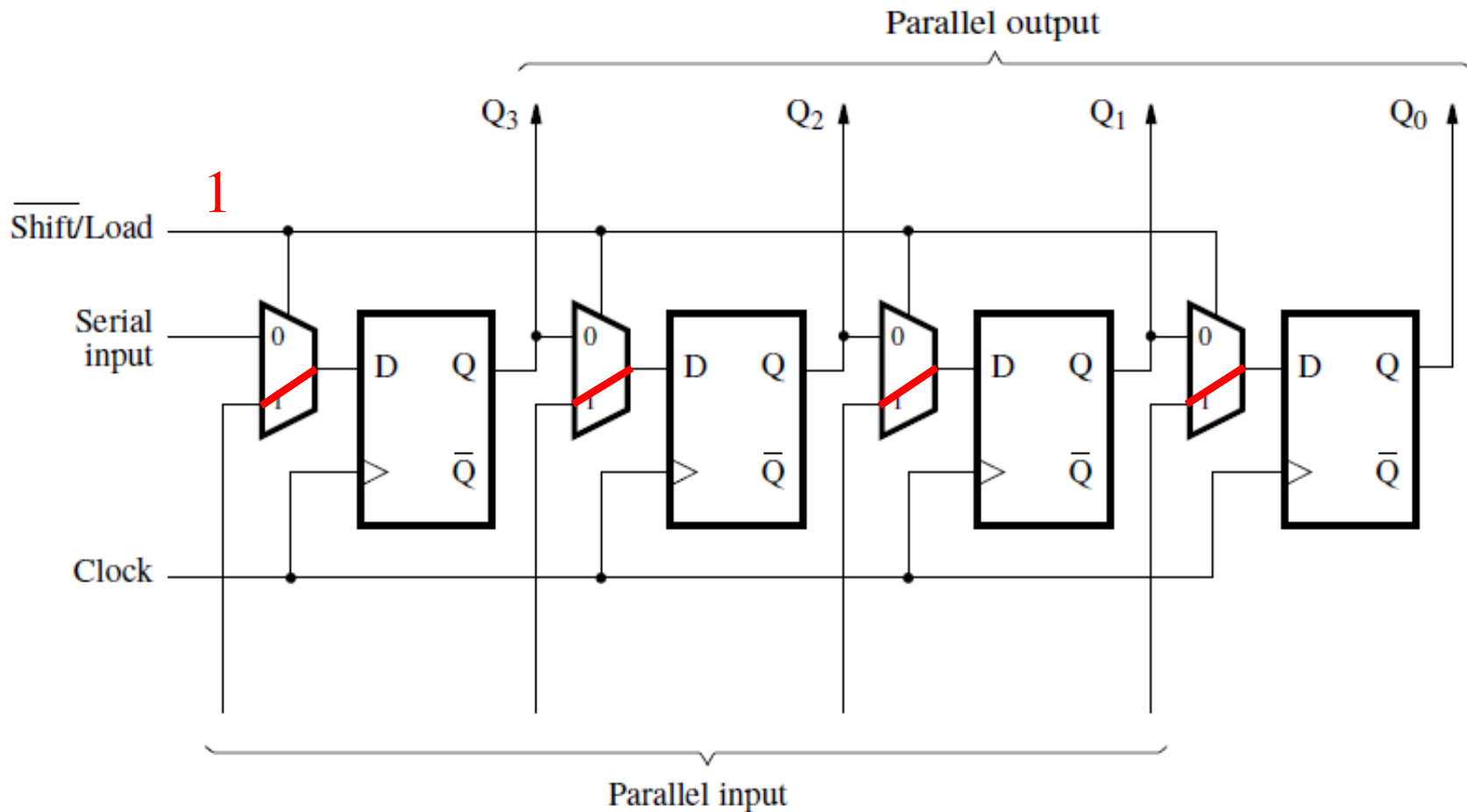

When Load=1, this behaves like a parallel-access register.

Shift Register With Parallel Load and Enable

A shift register with parallel load and enable control inputs

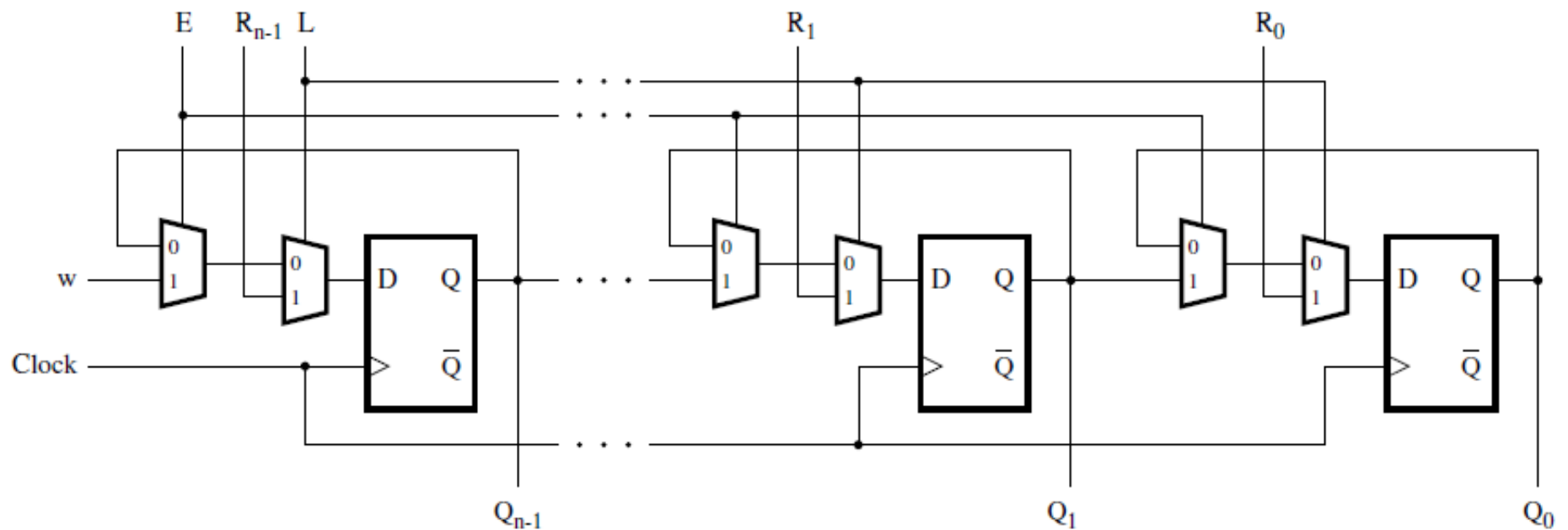

[Figure 5.59 from the textbook]

A shift register with parallel load and enable control inputs

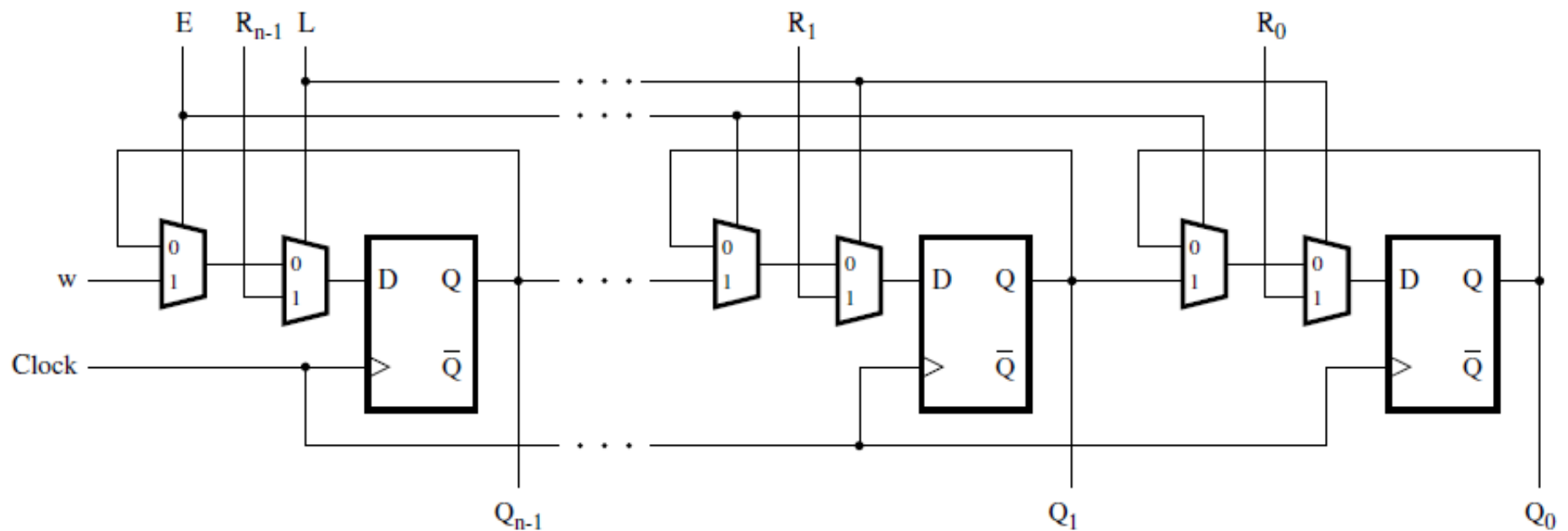

The directions of the input and output lines are switched relative to the previous slides.

A shift register with parallel load and enable control inputs

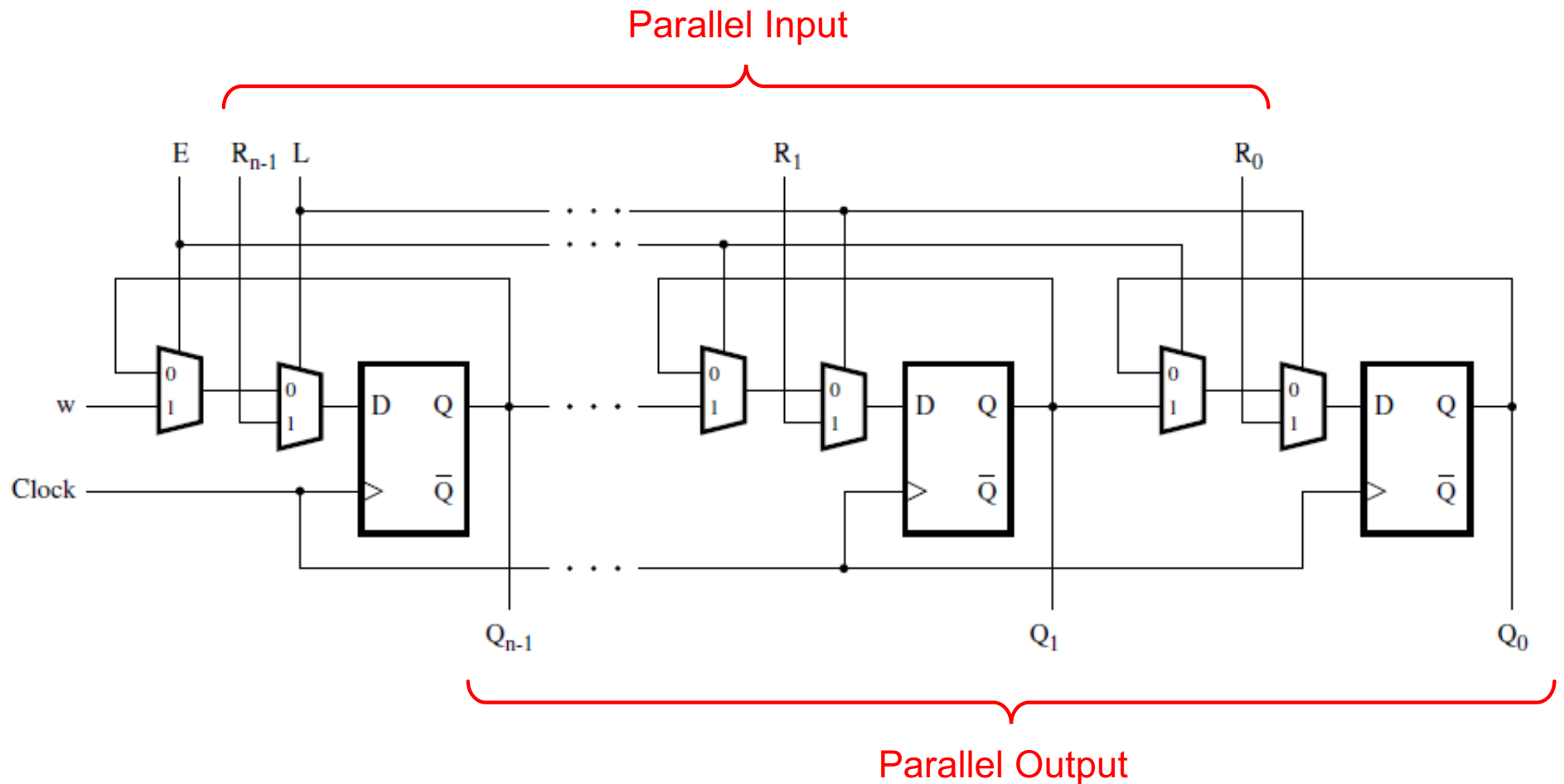

A shift register with parallel load and enable control inputs

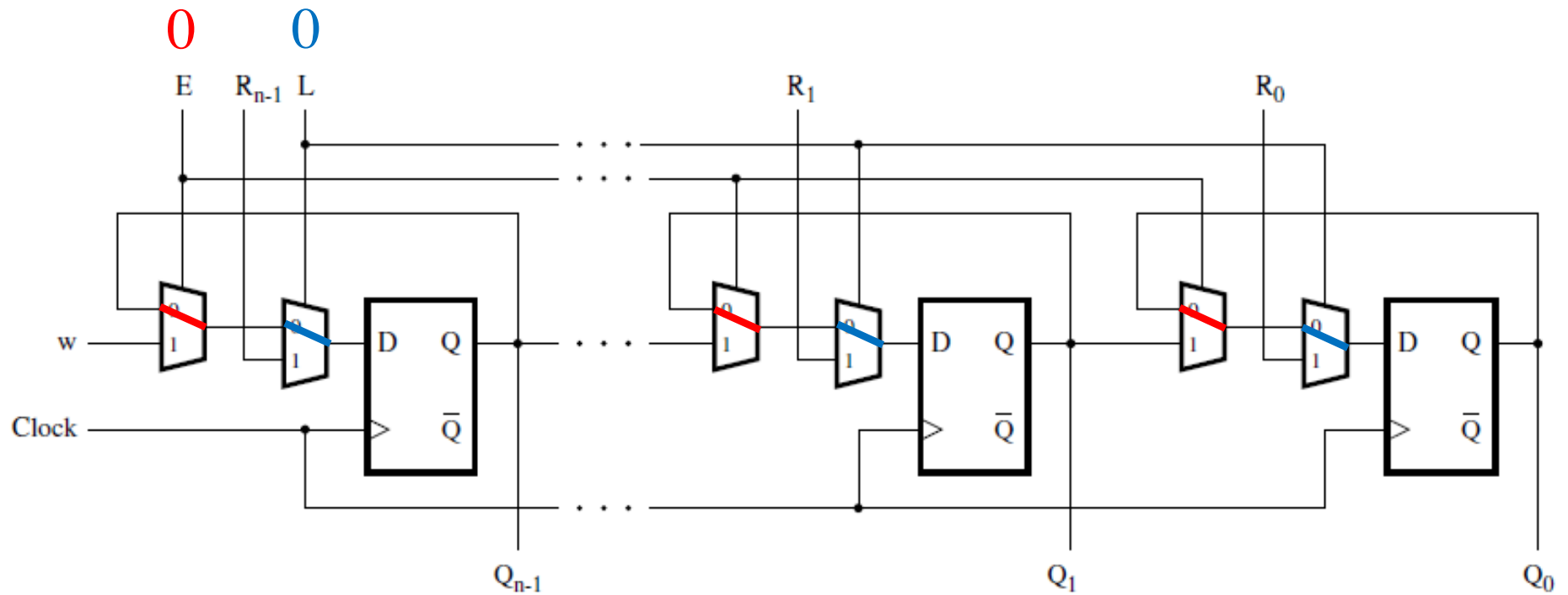

[Figure 5.59 from the textbook]

A shift register with parallel load and enable control inputs

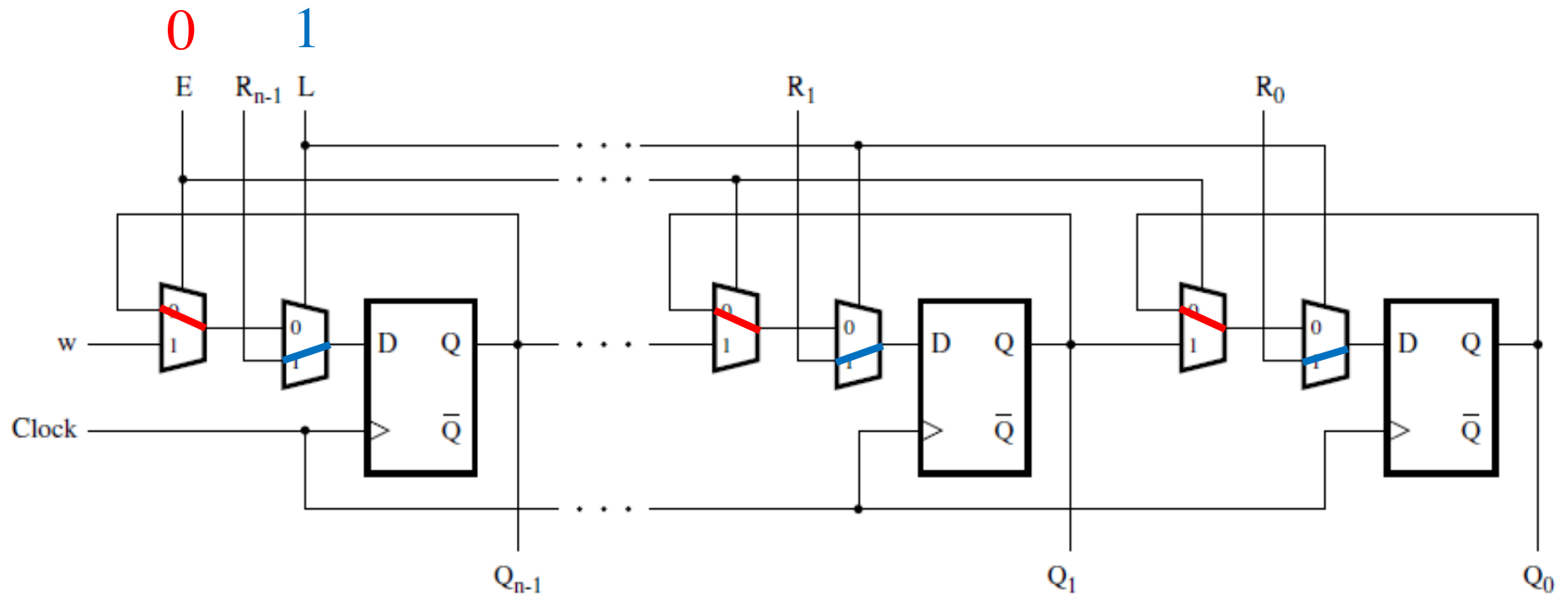

[Figure 5.59 from the textbook]

A shift register with parallel load and enable control inputs

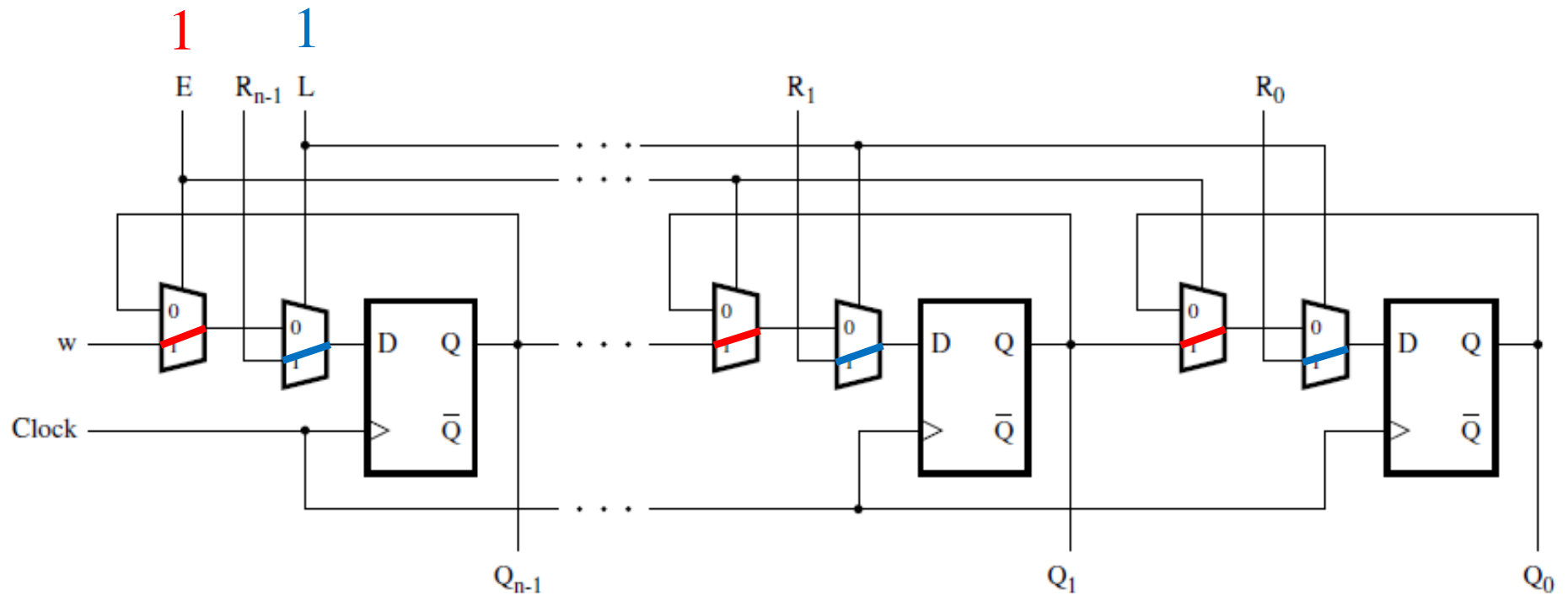

[Figure 5.59 from the textbook]

Multiplexer Tricks

(select one of two 2-bit numbers)

Select Either $A=A_1A_0$ or $B=B_1B_0$

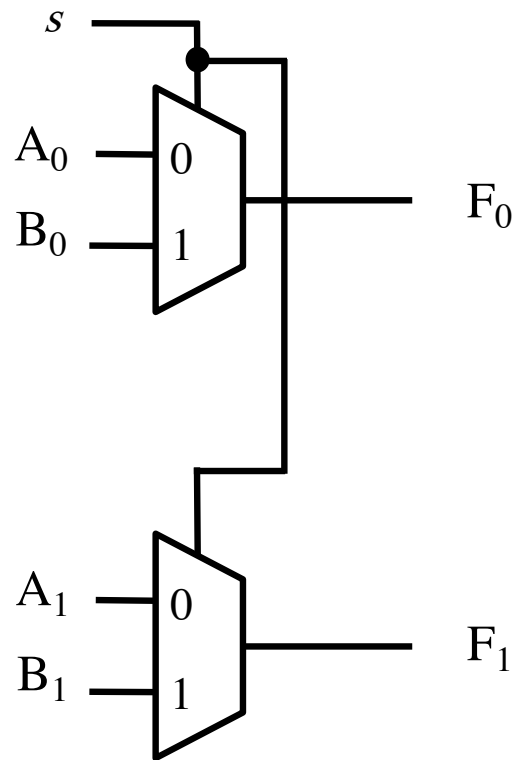

Select Either $A=A_1A_0$ or $B=B_1B_0$

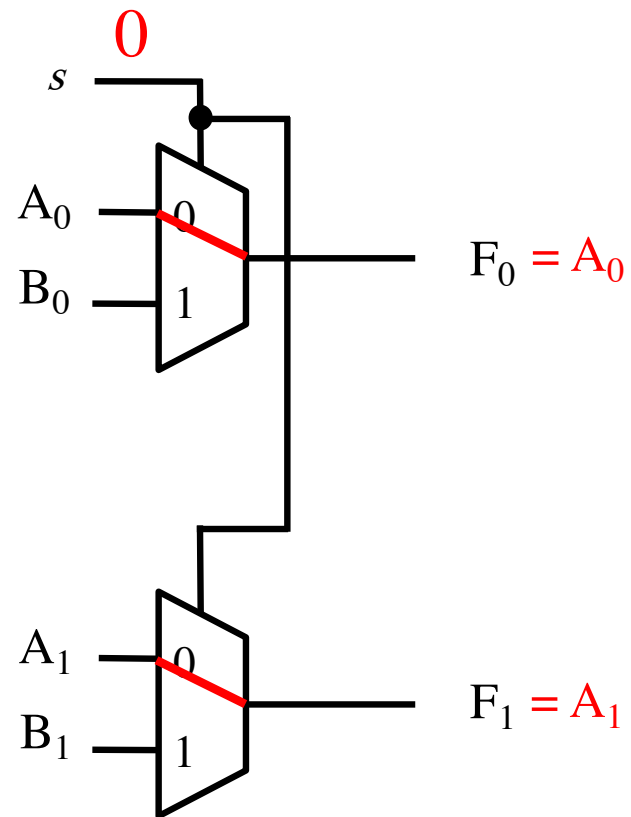

Select Either $A=A_1A_0$ or $B=B_1B_0$

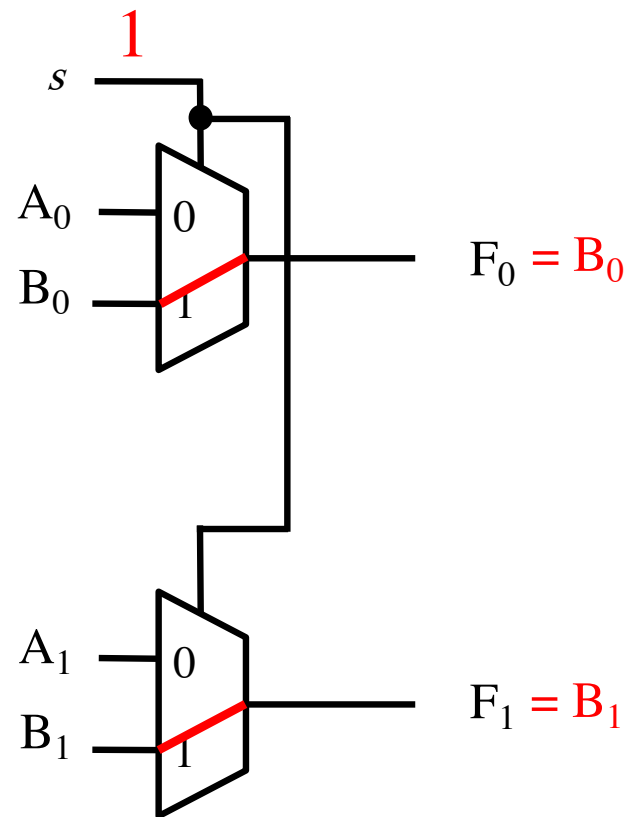

Multiplexer Tricks

(select one of four 2-bit numbers)

Select $A=A_1A_0$ or $B=B_1B_0$ or $C=C_1C_0$ or $D=D_1D_0$

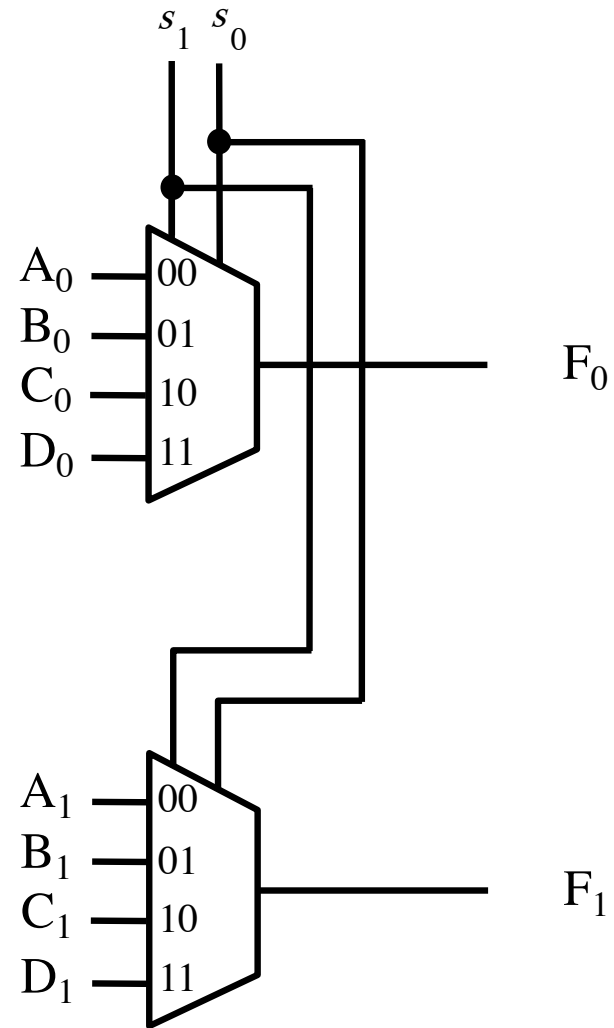

Select $A=A_1A_0$ or $B=B_1B_0$ or $C=C_1C_0$ or $D=D_1D_0$

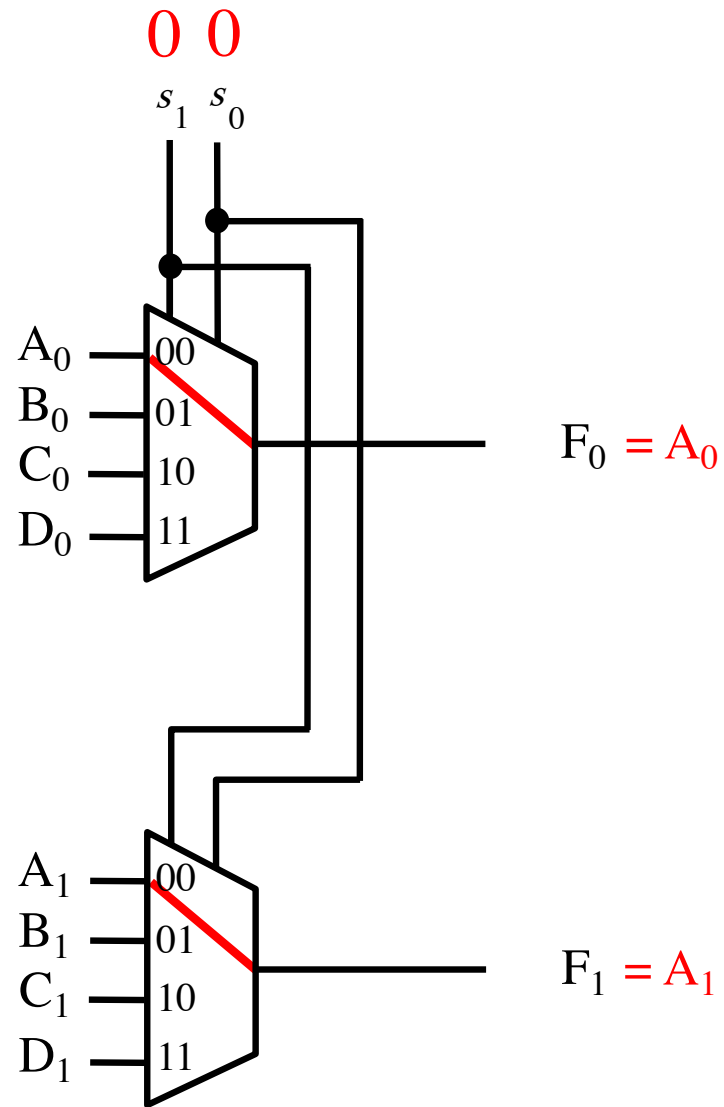

Select $A=A_1A_0$ or $B=B_1B_0$ or $C=C_1C_0$ or $D=D_1D_0$

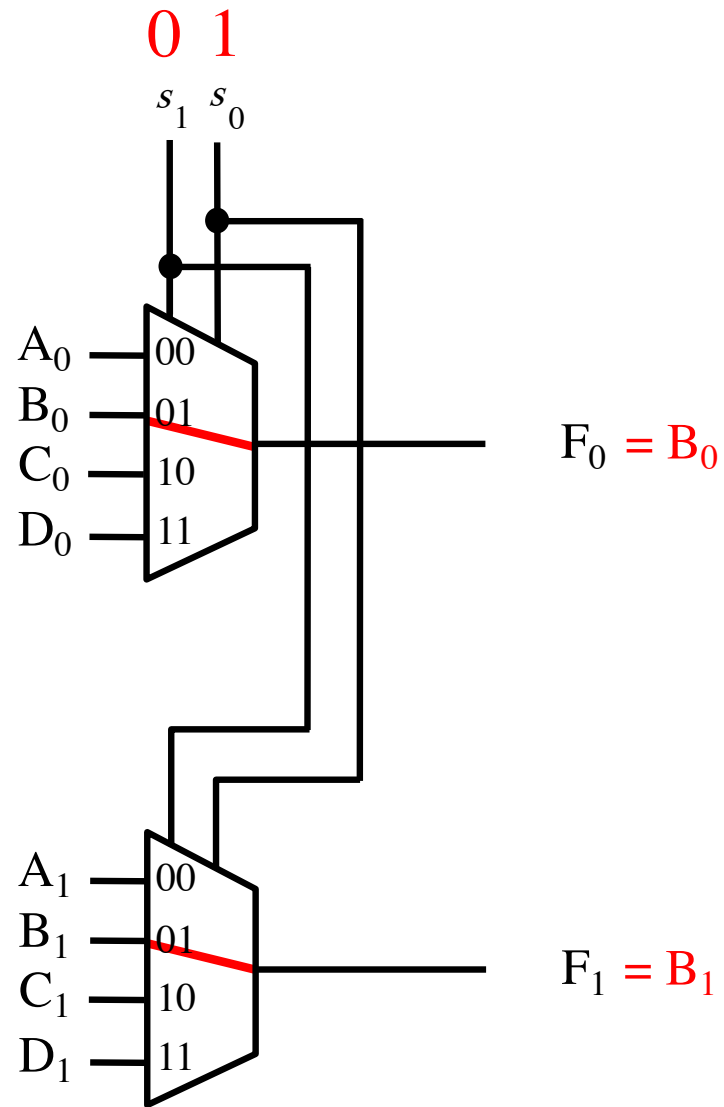

Select $A=A_1A_0$ or $B=B_1B_0$ or $C=C_1C_0$ or $D=D_1D_0$

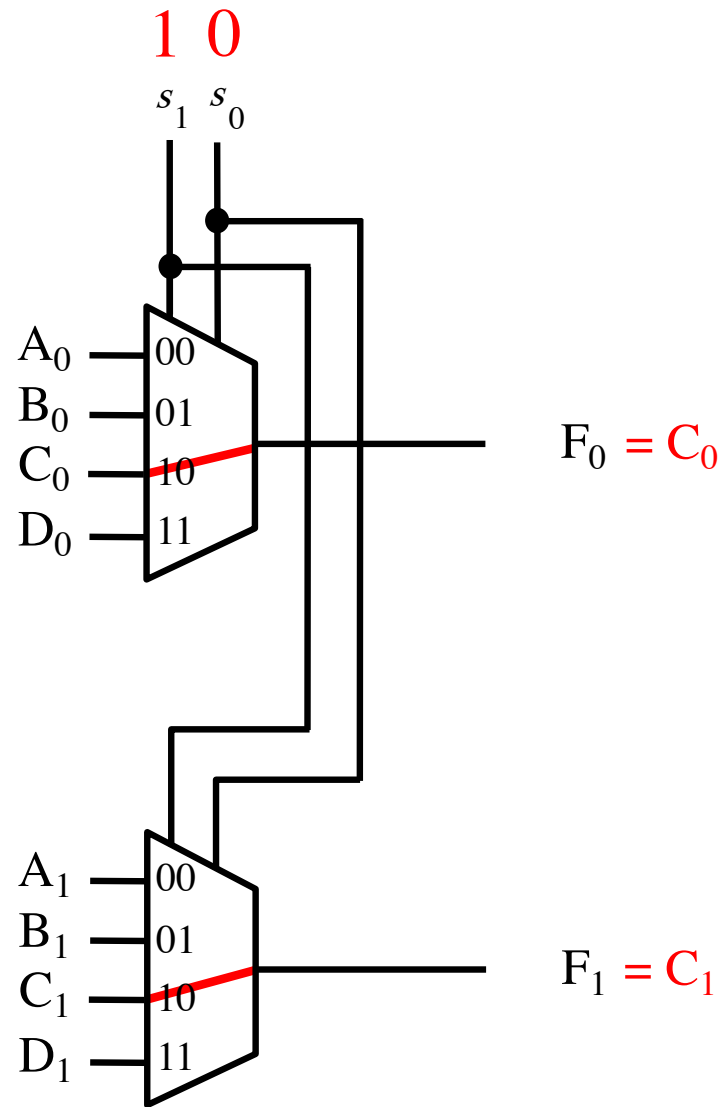

Select $A=A_1A_0$ or $B=B_1B_0$ or $C=C_1C_0$ or $D=D_1D_0$

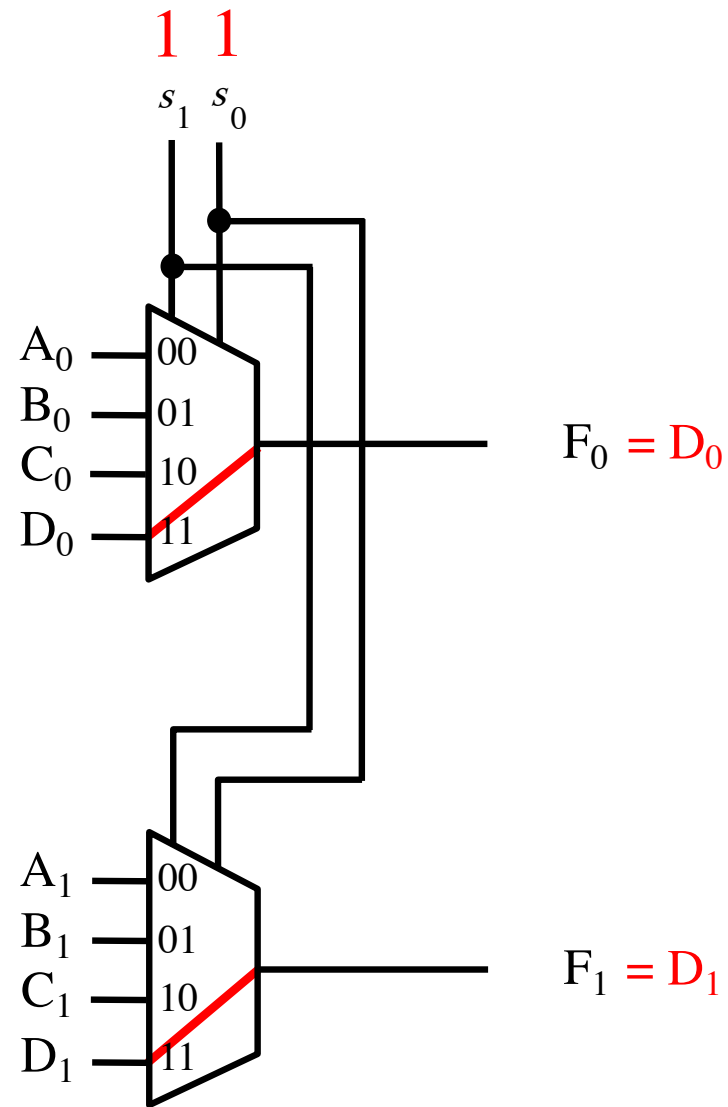

Register File

Complete the following circuit diagram to implement a register file with four 2-bit registers, one write port, one read port, and one write enable line.

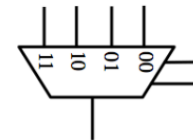
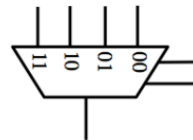
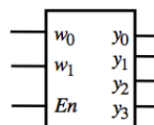
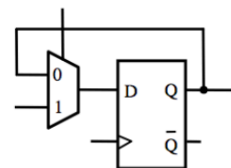
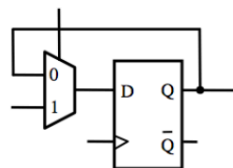
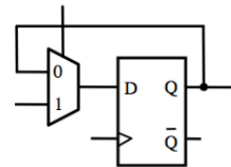
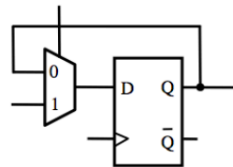
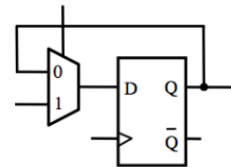
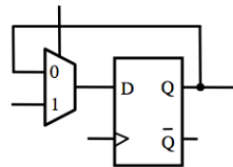
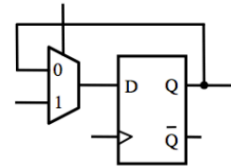
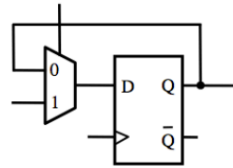

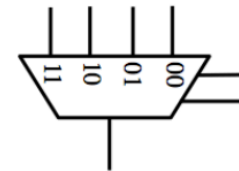
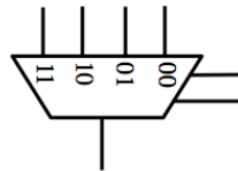
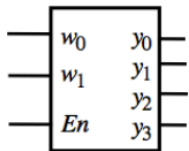
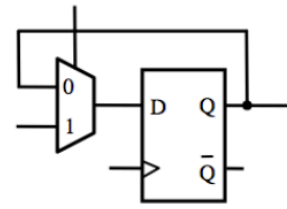
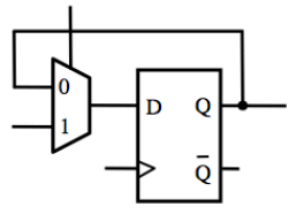
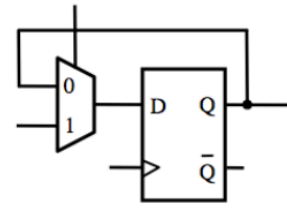
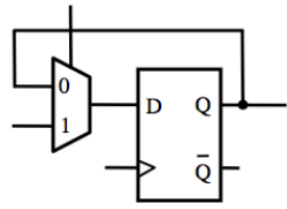
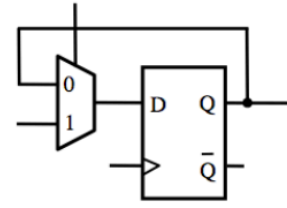
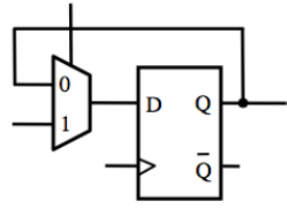
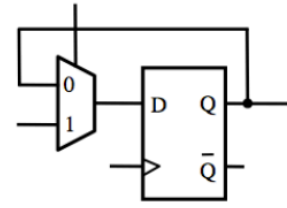
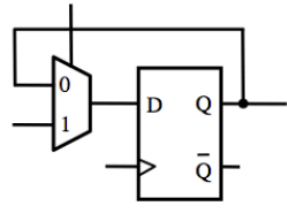

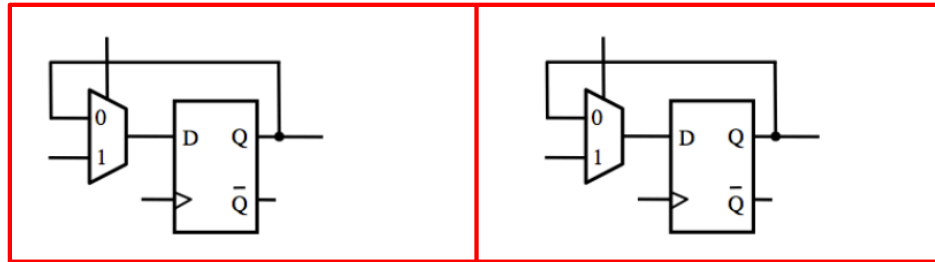

Register 0

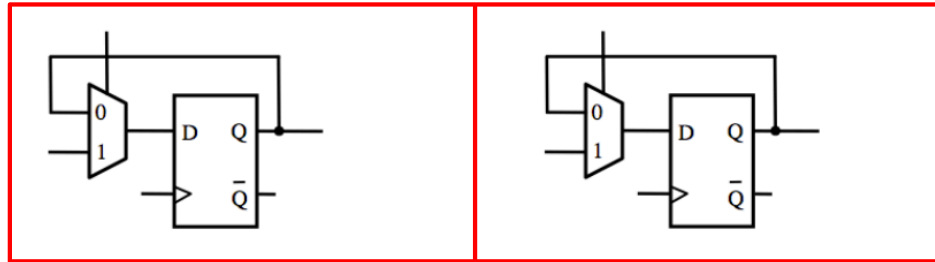

Register 1

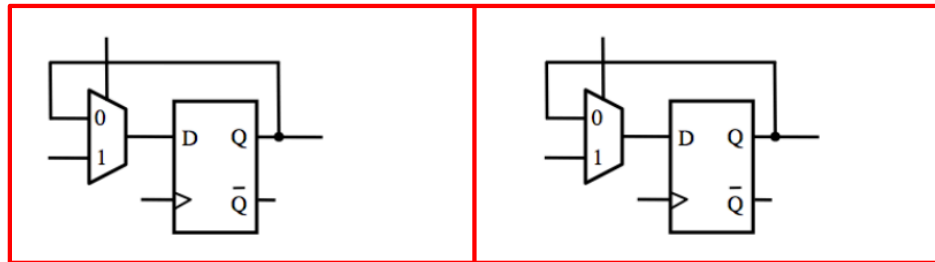

Register 2

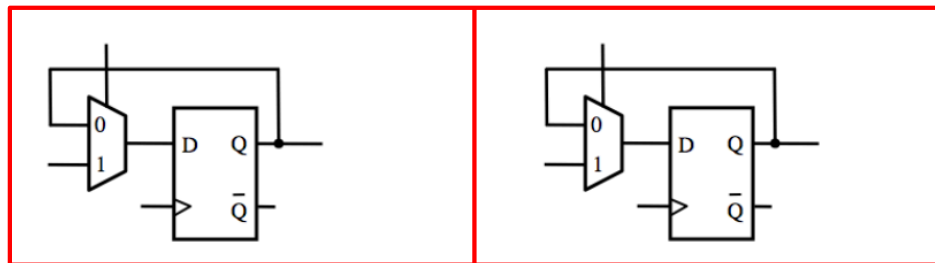

Register 3

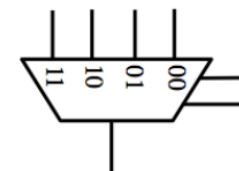
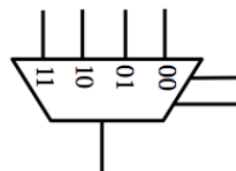
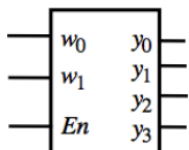

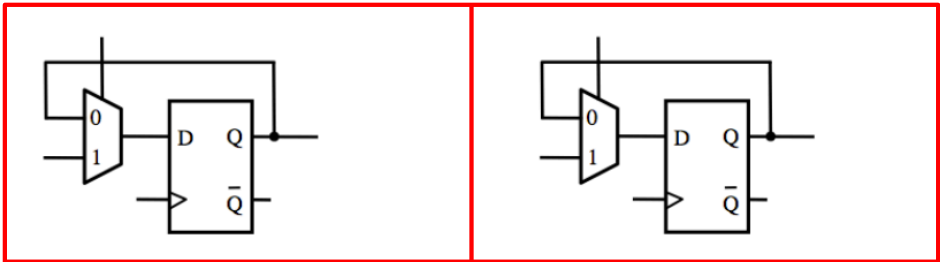

Register A

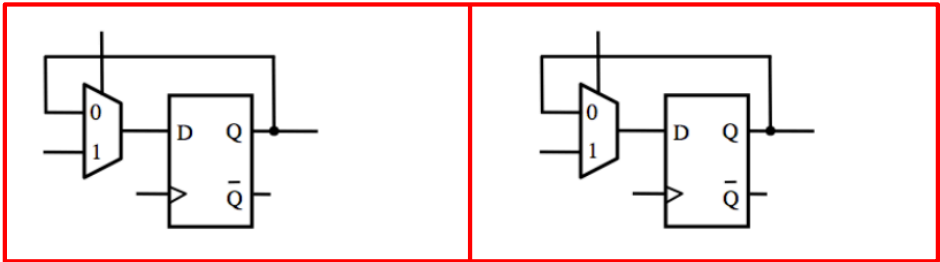

Register B

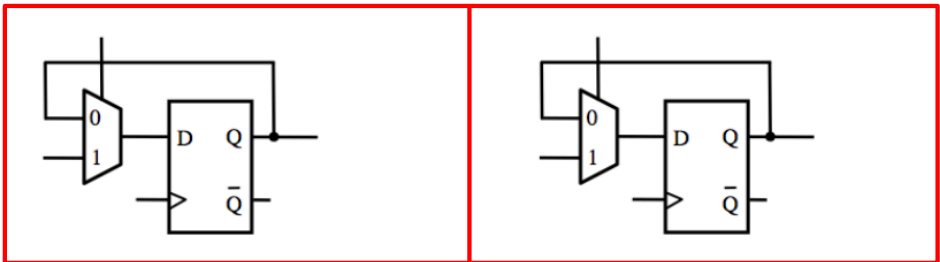

Register C

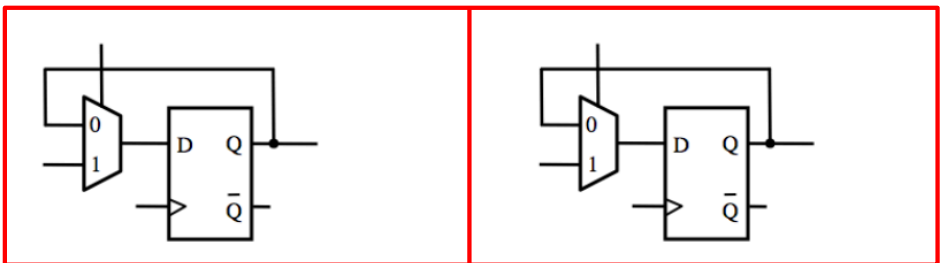

Register D

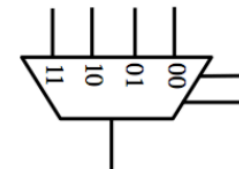
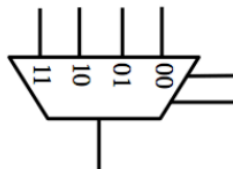
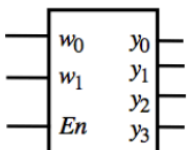

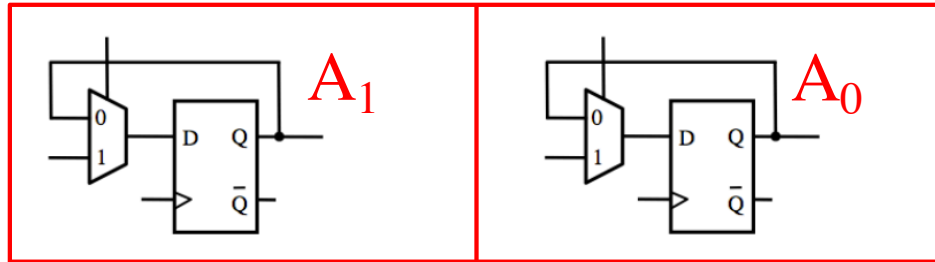

Register A

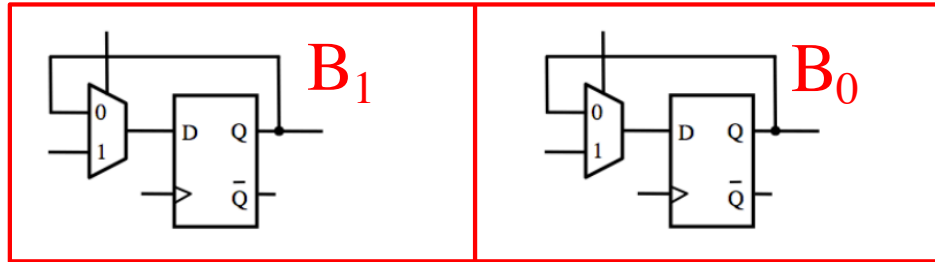

Register B

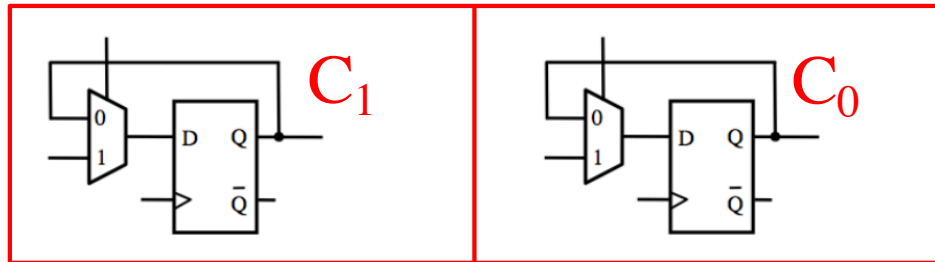

Register C

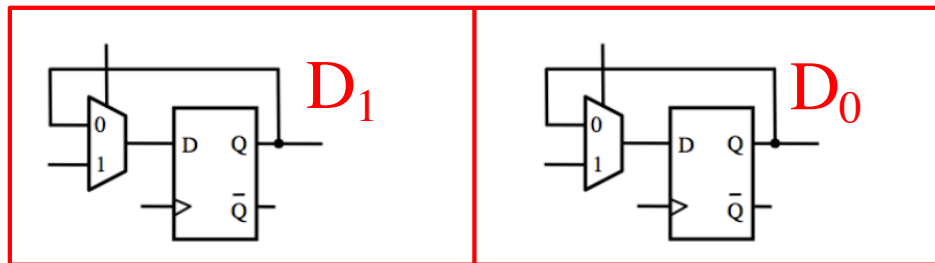

Register D

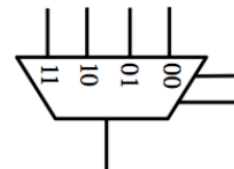
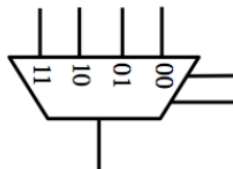
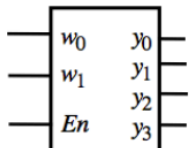

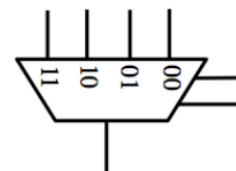
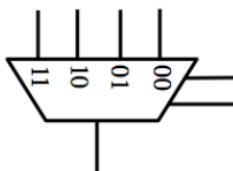
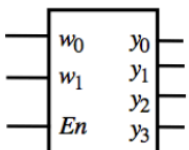
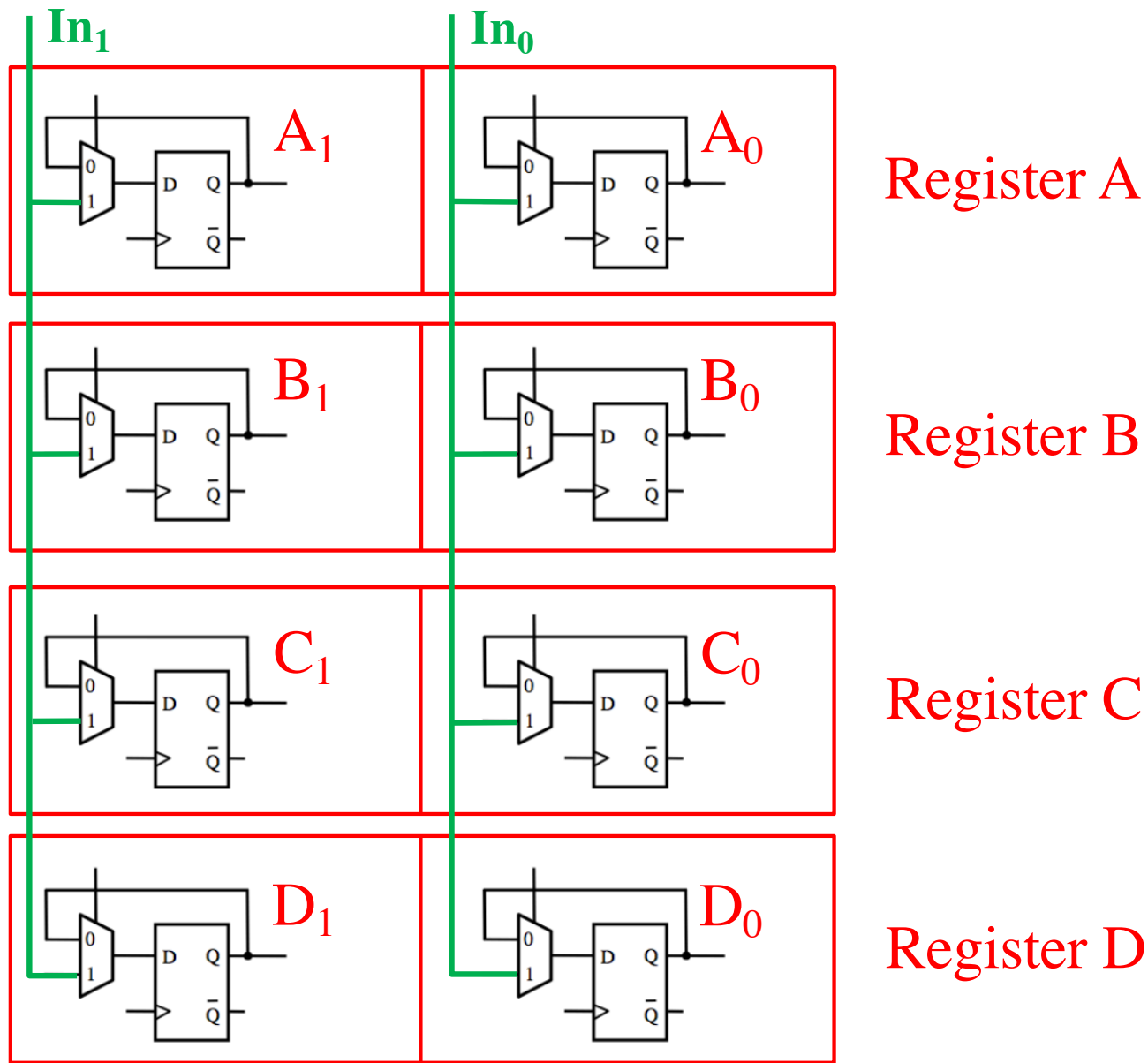

In_1

In_0

A_1

A_0

Register A

B_1

B_0

Register B

C_1

C_0

Register C

D_1

D_0

Register D

Write_address_0
Write_address_1
Write_enable

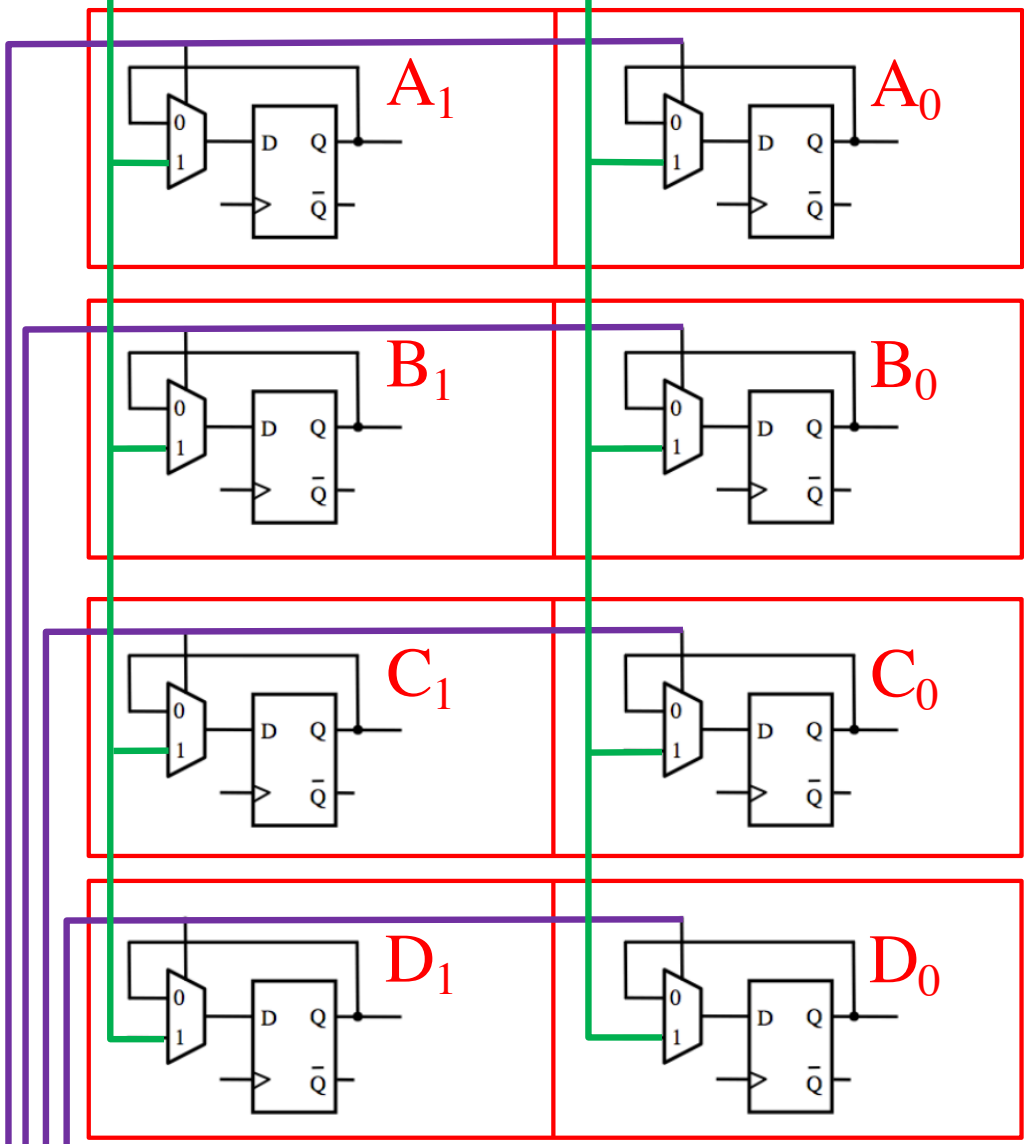
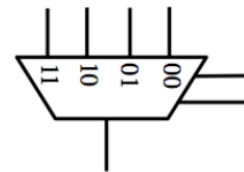
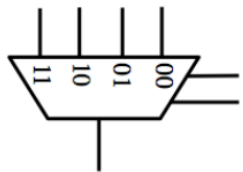
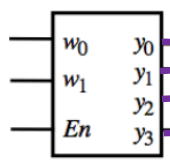

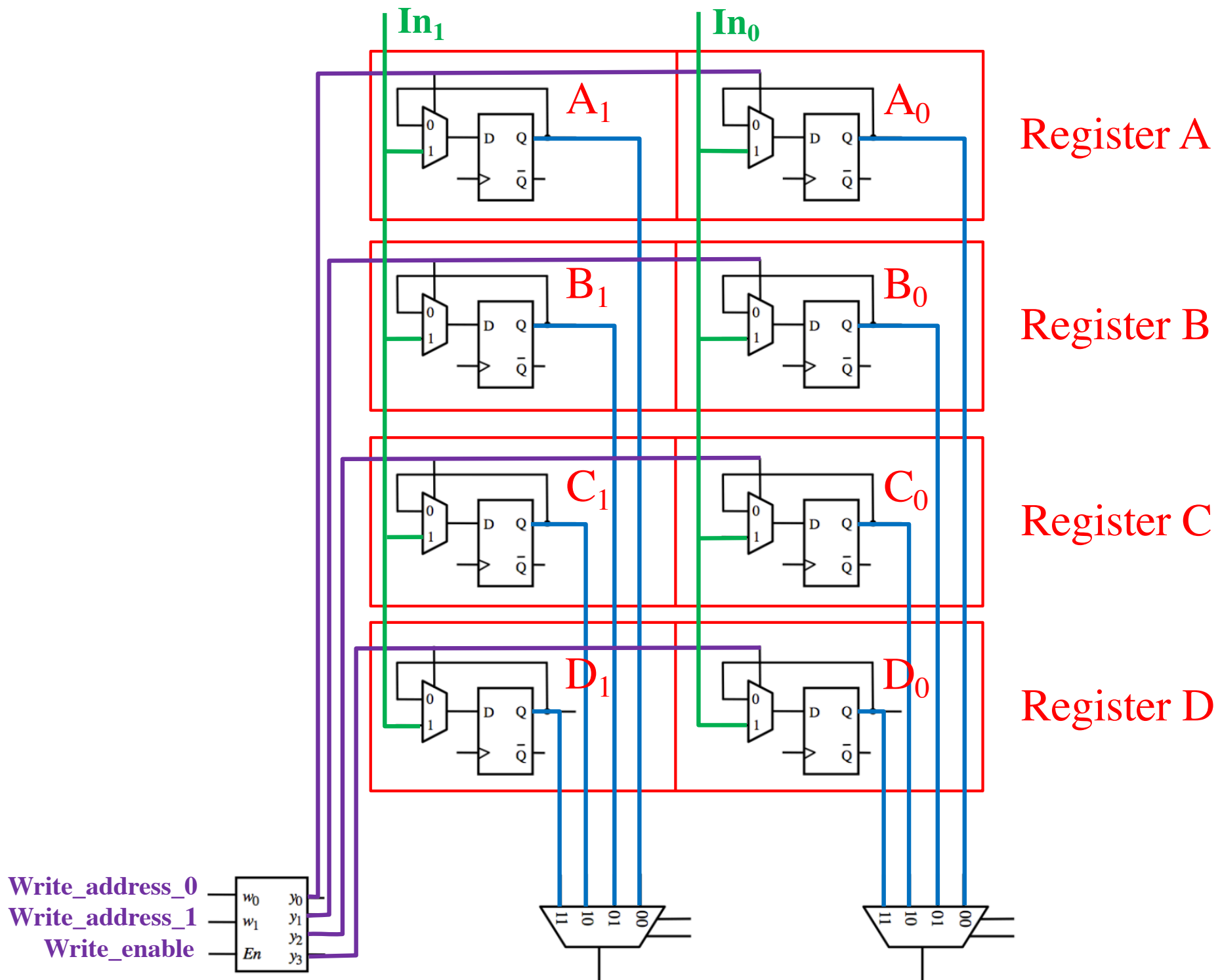

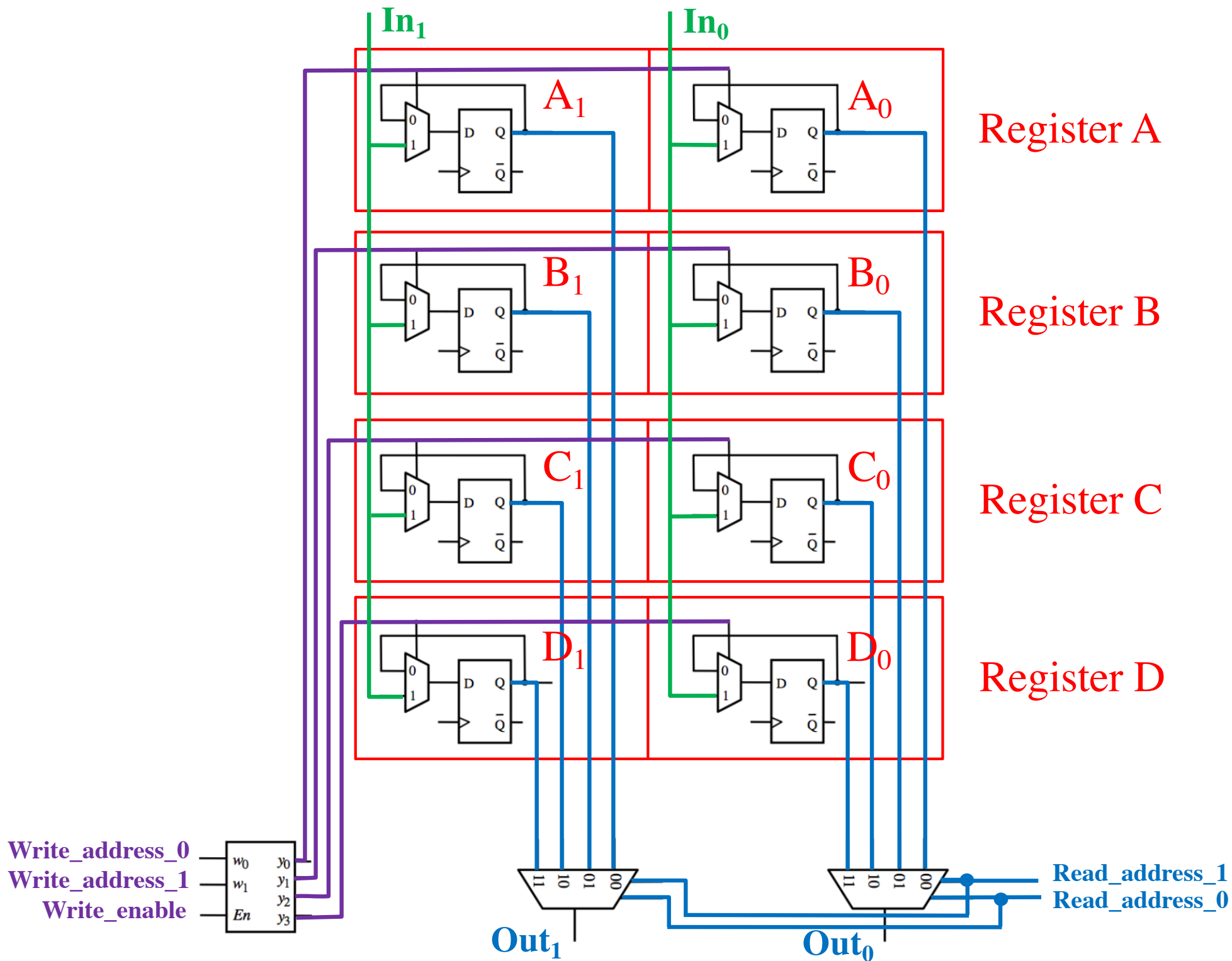

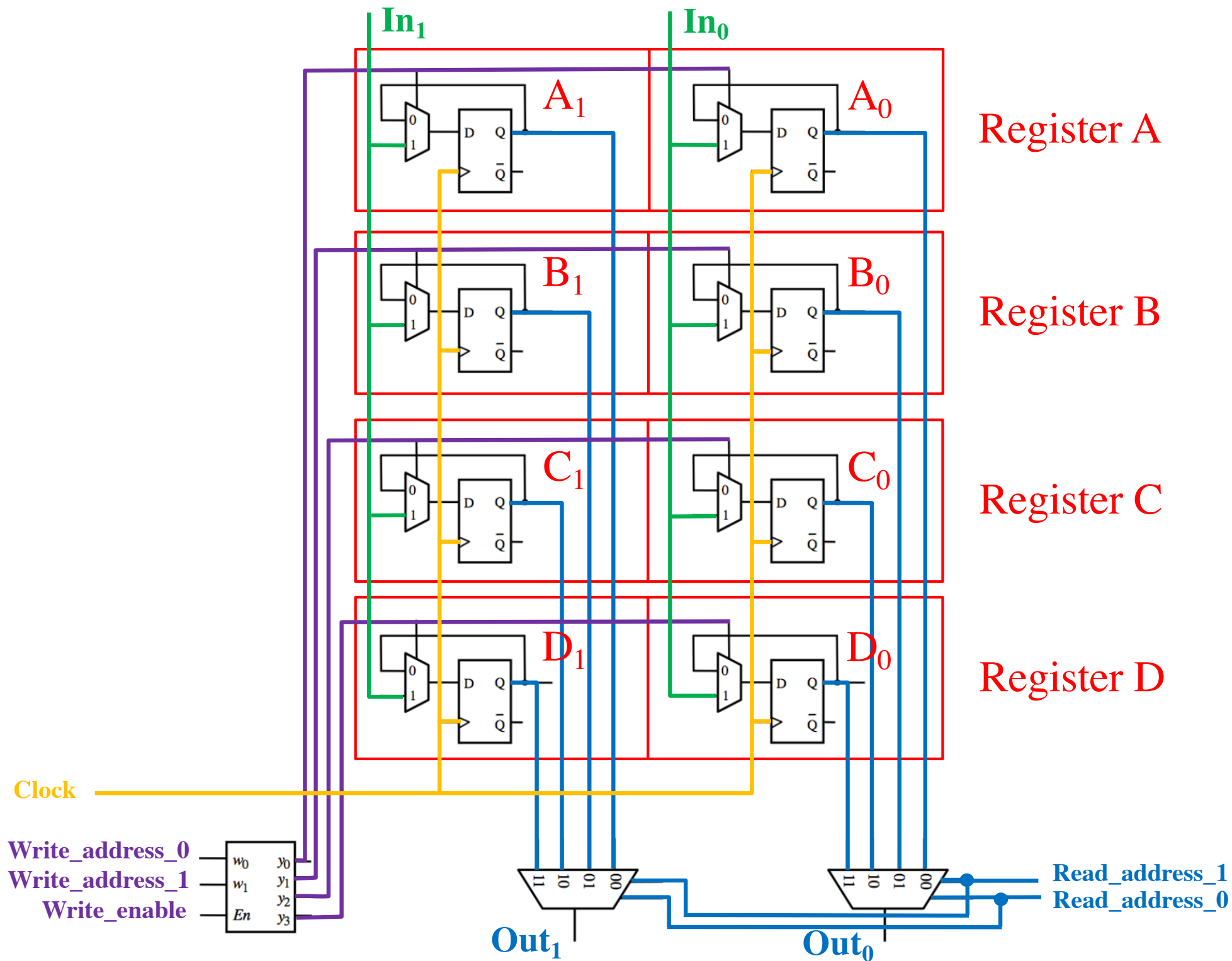

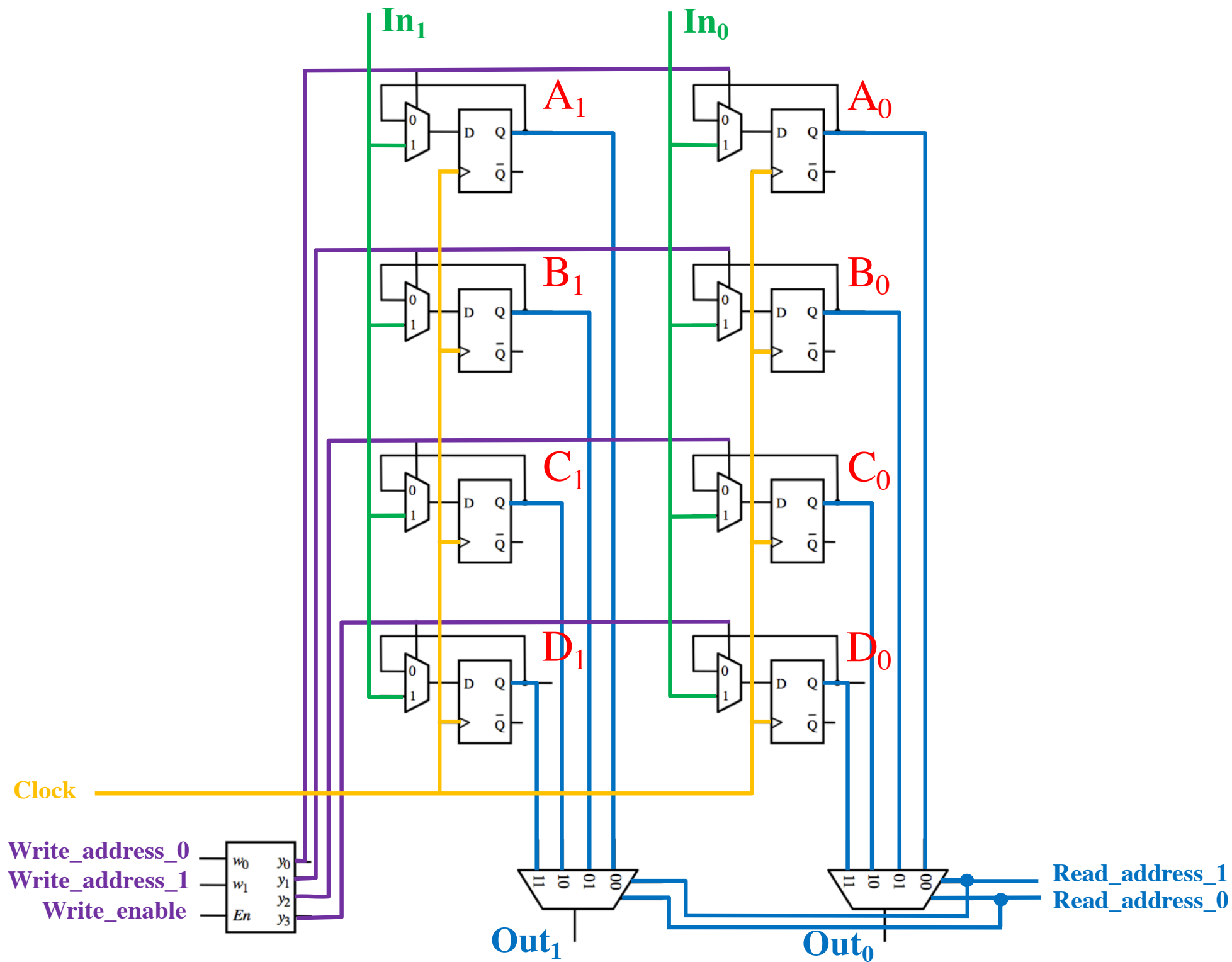

Counters

**The output of the T Flip-Flop
divides the frequency of the clock by 2**

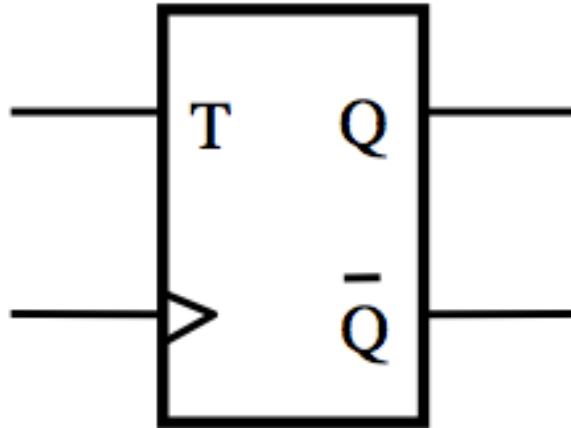

**The output of the T Flip-Flop
divides the frequency of the clock by 2**

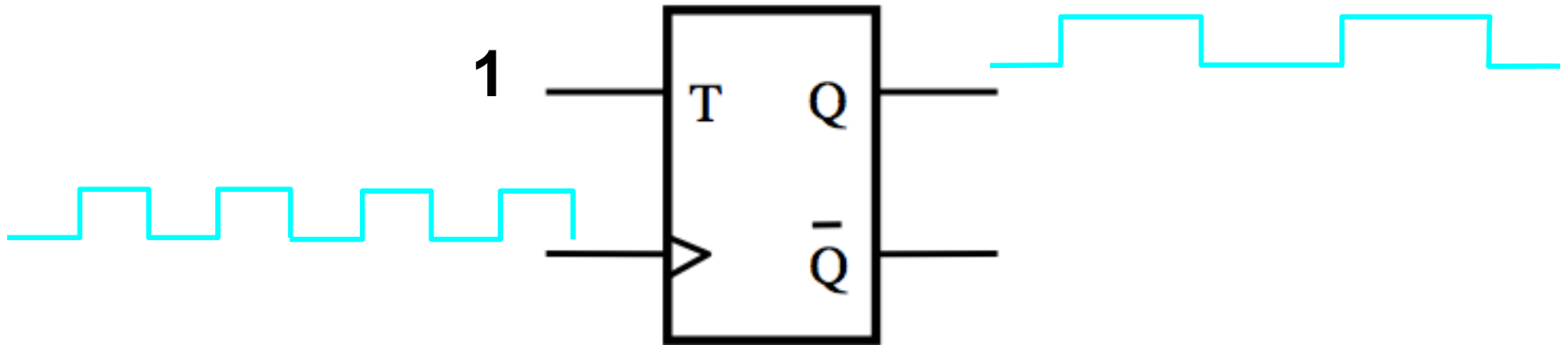

A three-bit down-counter

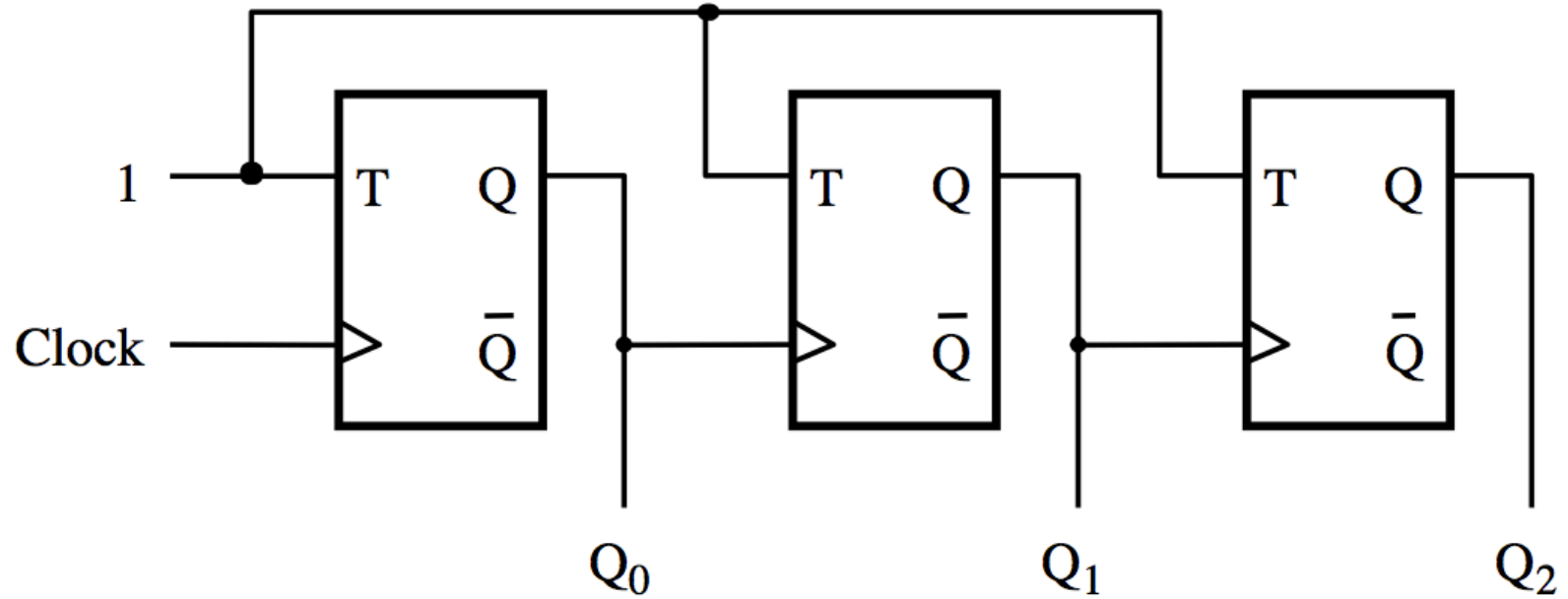

A three-bit down-counter

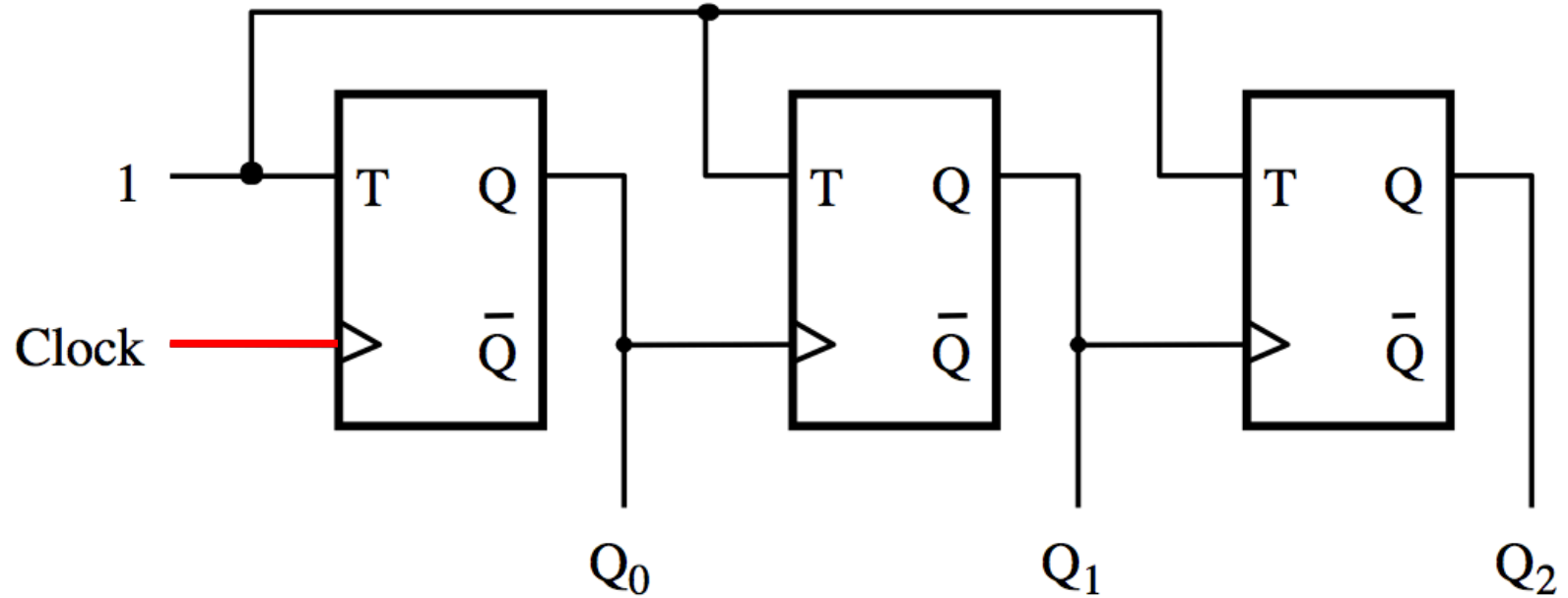

The first flip-flop changes
on the positive edge of the clock

A three-bit down-counter

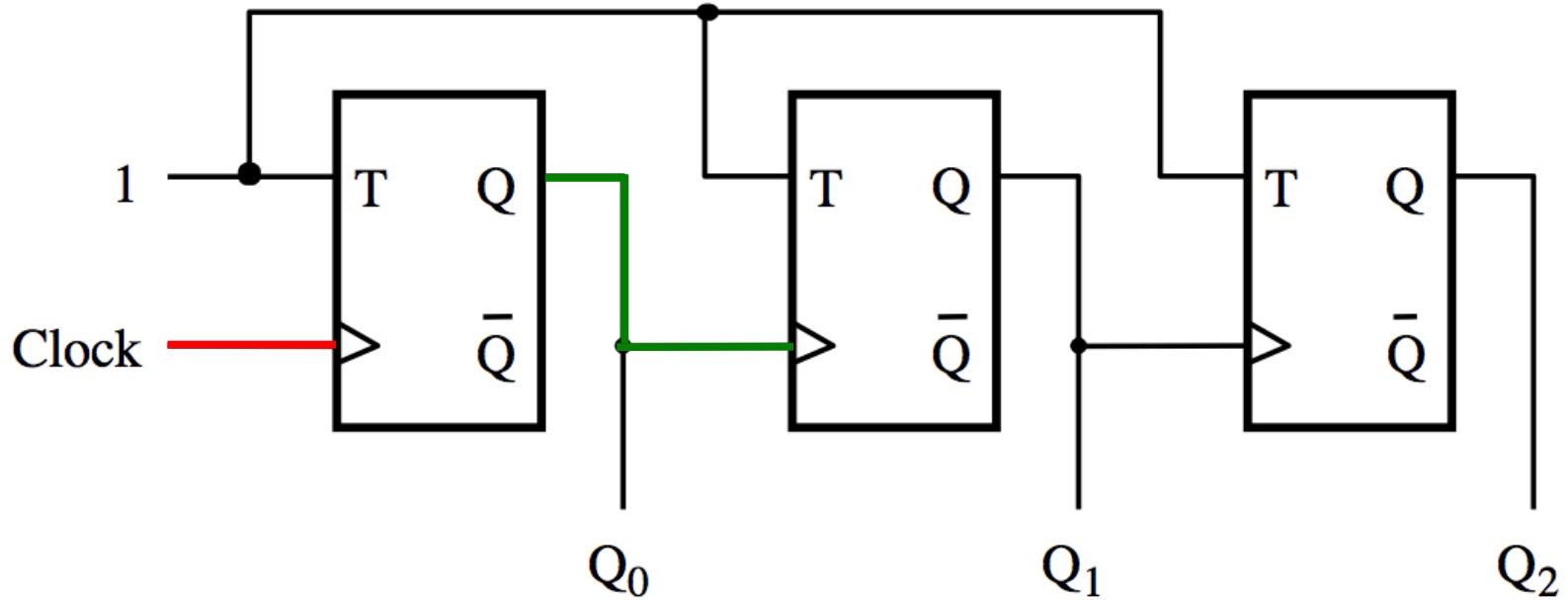

The first flip-flop changes
on the positive edge of the clock

The second flip-flop changes
on the positive edge of Q_0

A three-bit down-counter

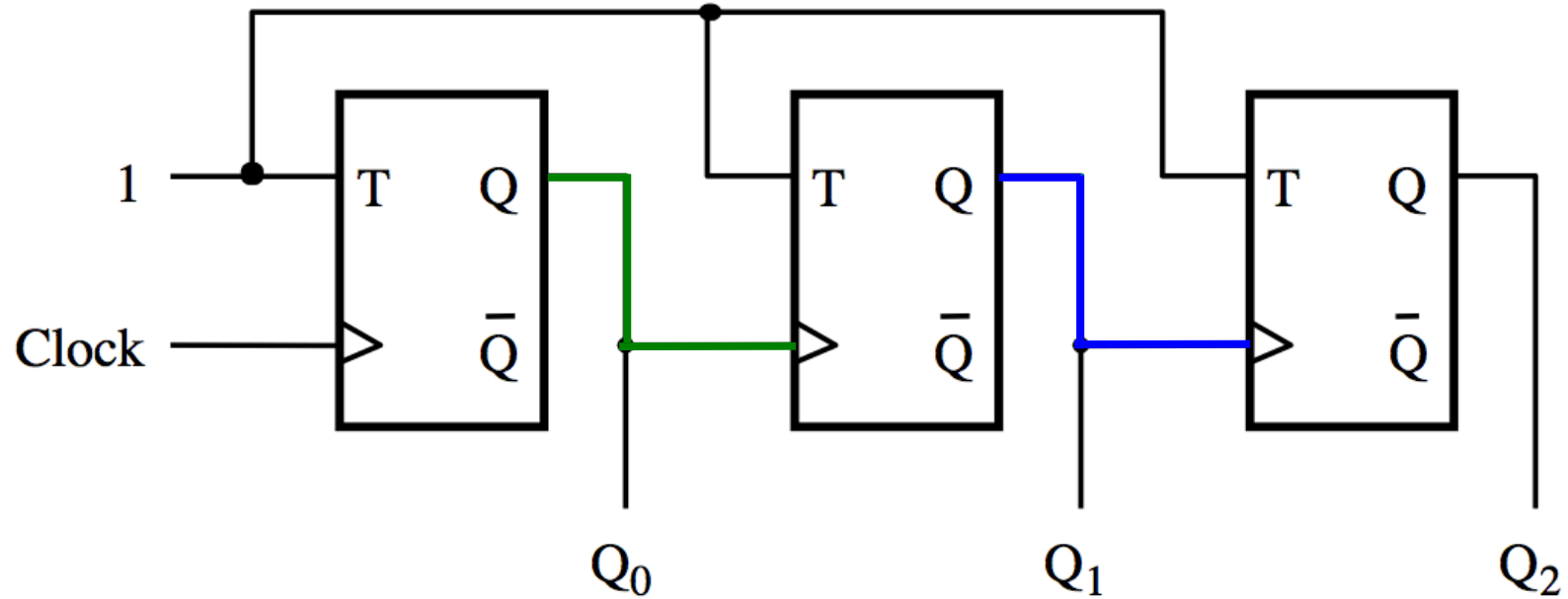

The first flip-flop changes
on the positive edge of the clock

The second flip-flop changes
on the positive edge of Q_0

The third flip-flop changes
on the positive edge of Q_1

A three-bit down-counter

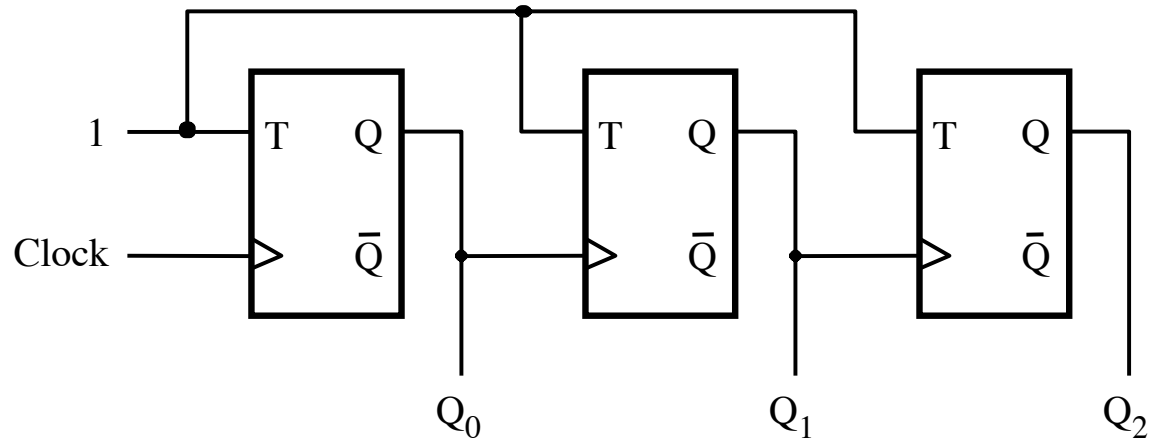

(a) Circuit

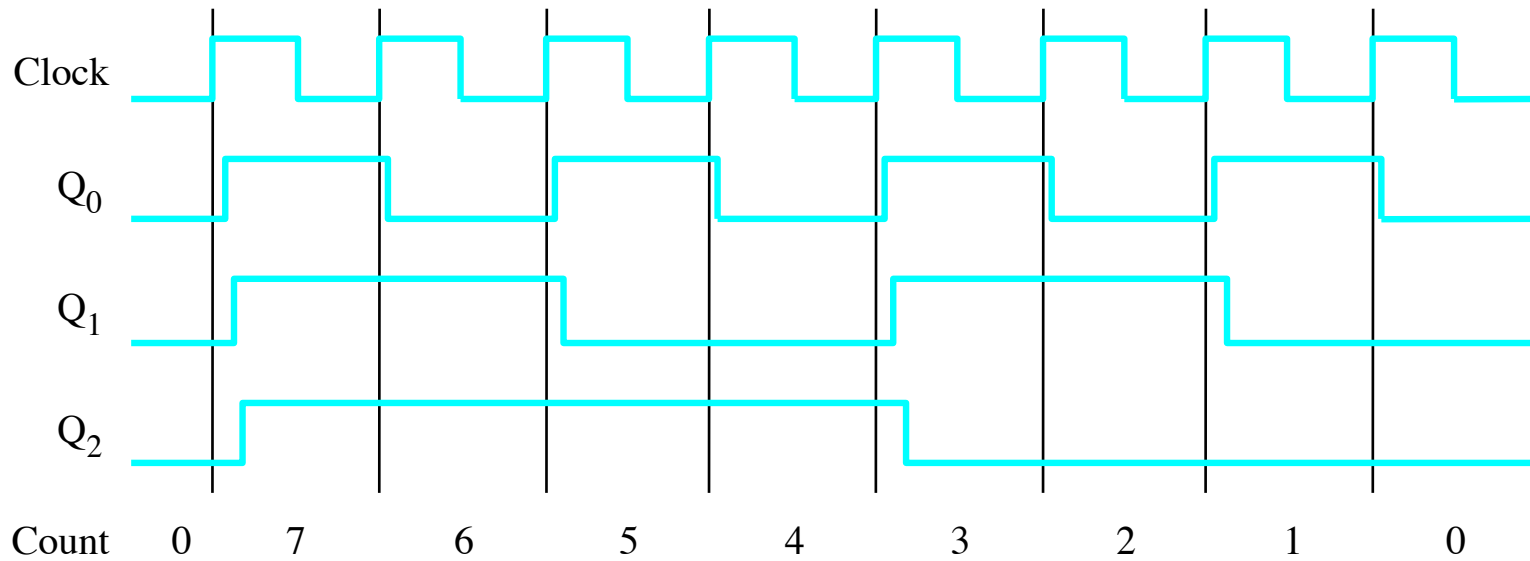

(b) Timing diagram

A three-bit down-counter

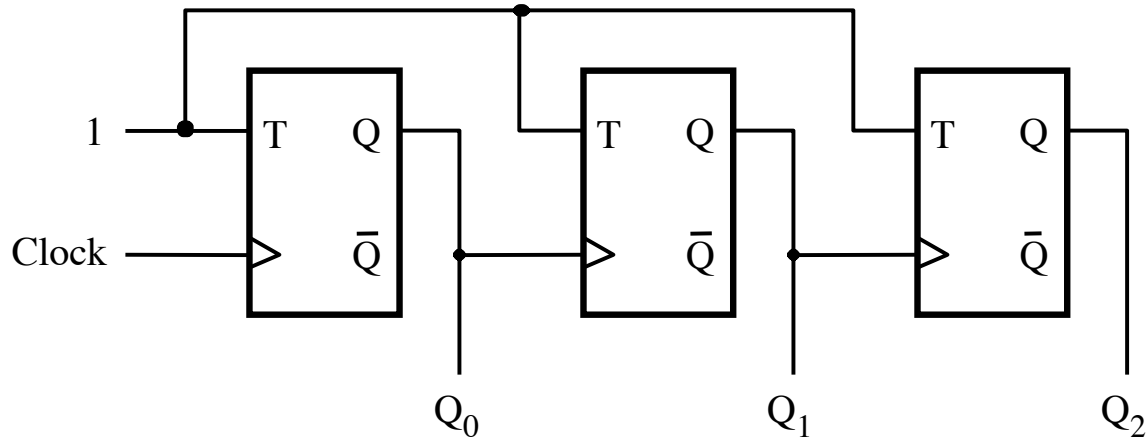

(a) Circuit

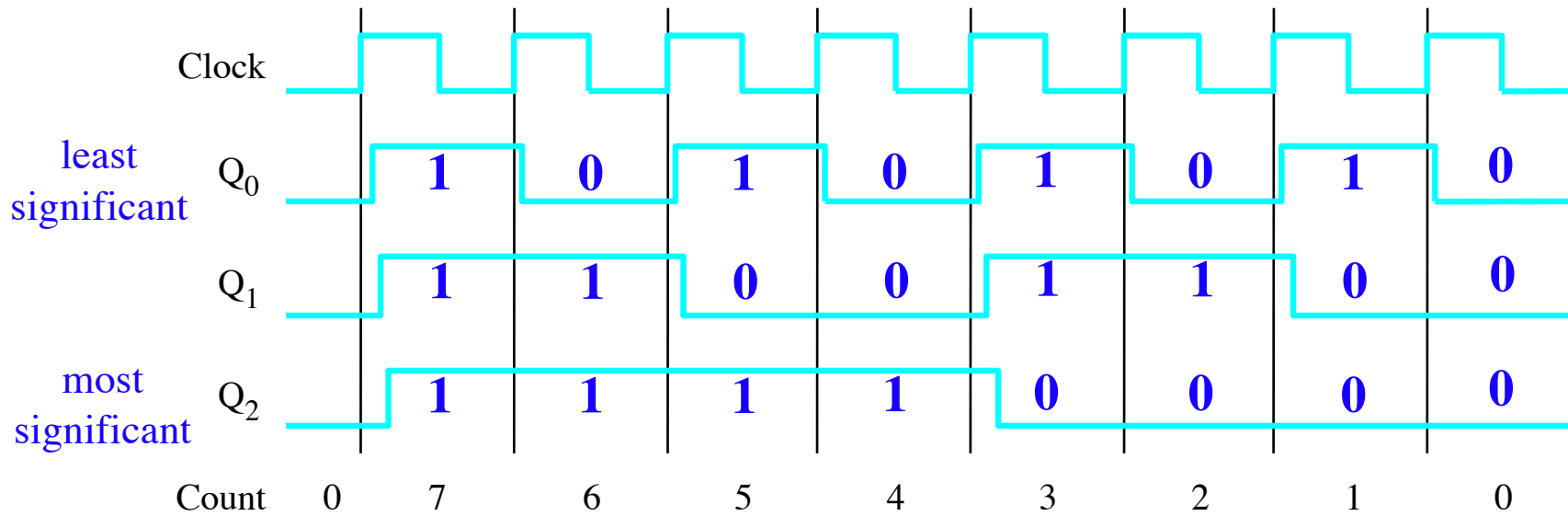

(b) Timing diagram

A three-bit down-counter

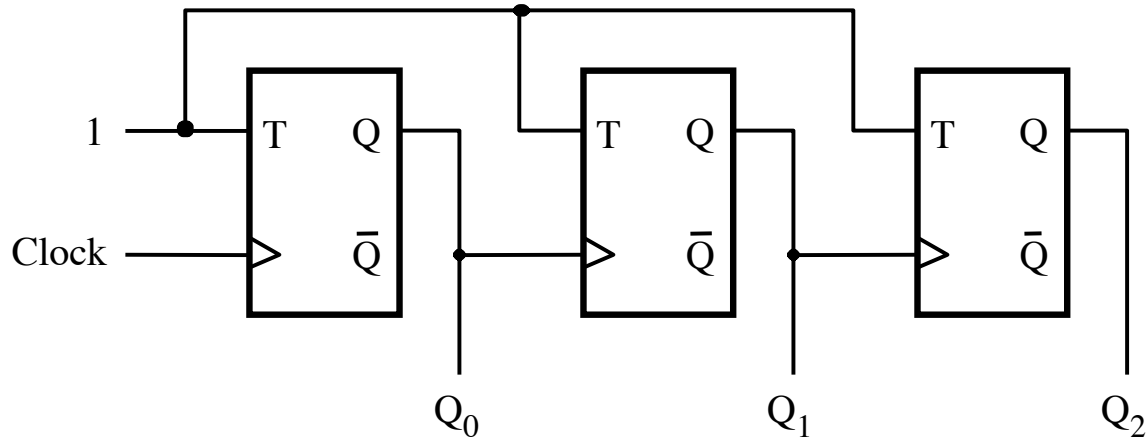

(a) Circuit

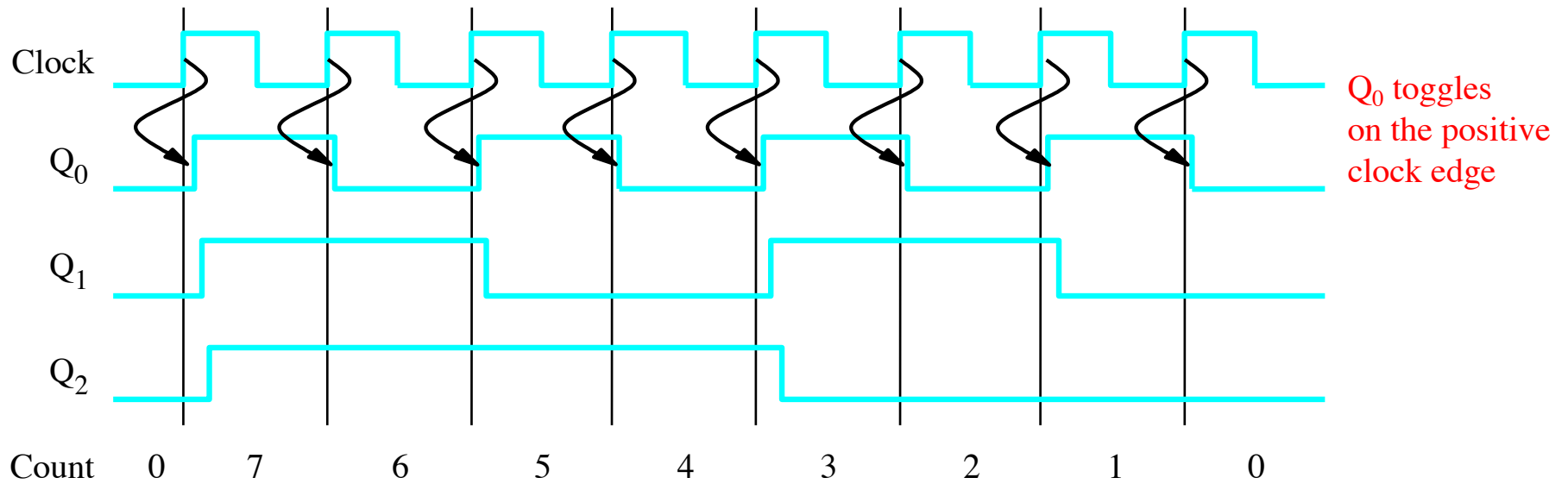

(b) Timing diagram

A three-bit down-counter

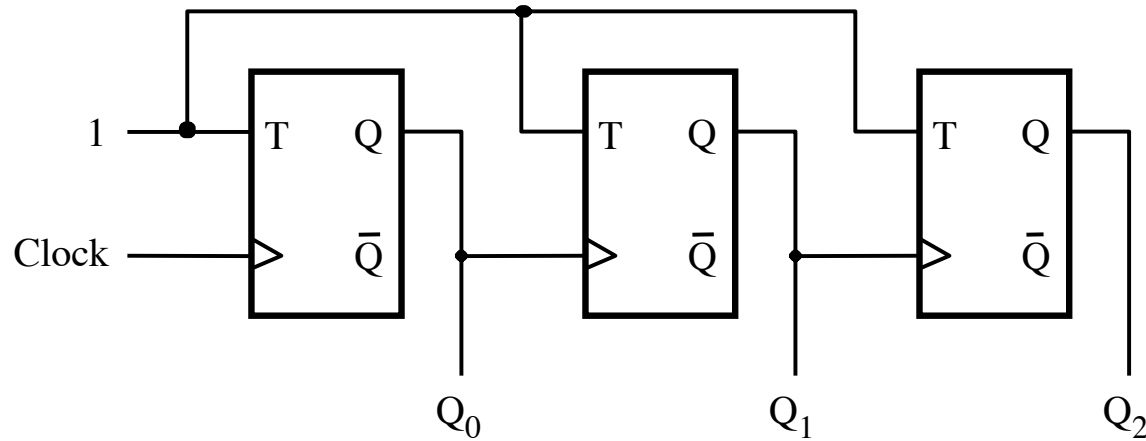

(a) Circuit

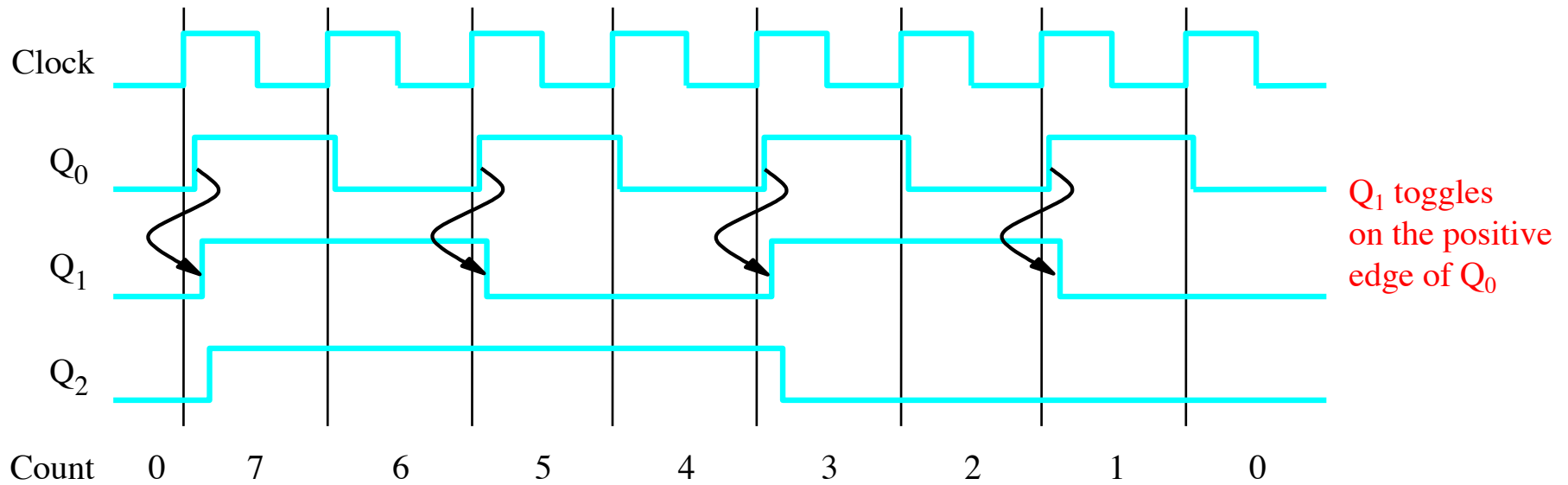

(b) Timing diagram

A three-bit down-counter

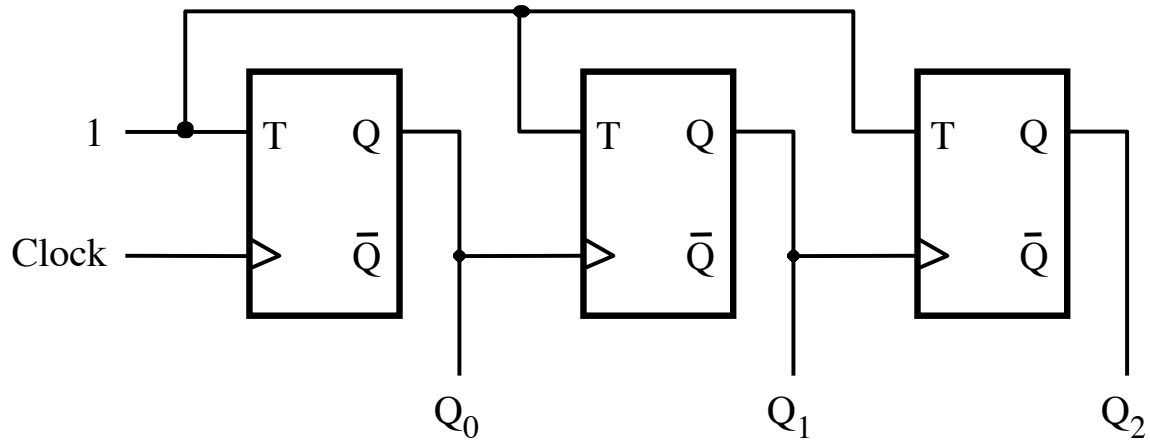

(a) Circuit

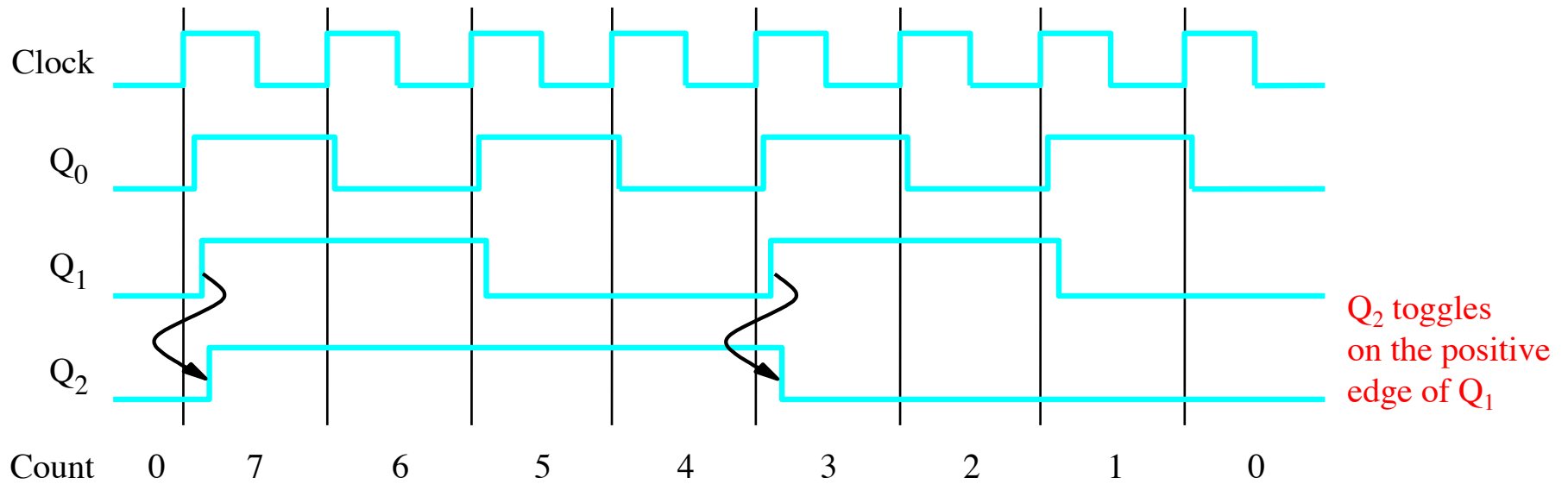

(b) Timing diagram

A three-bit down-counter

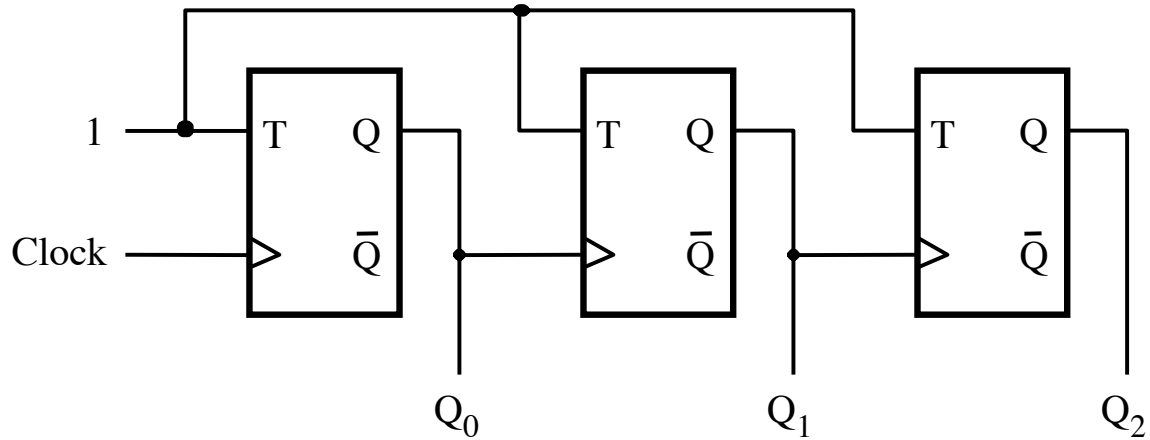

(a) Circuit

The propagation delays get longer

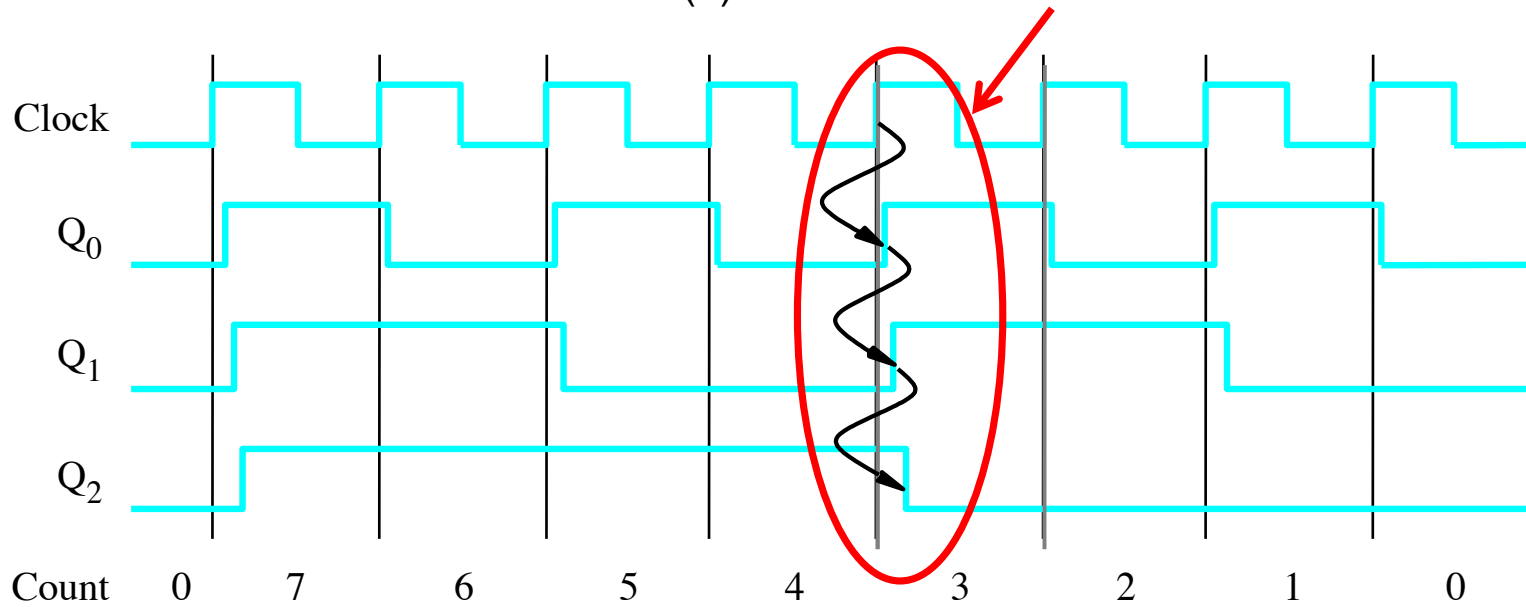

(b) Timing diagram

A three-bit up-counter

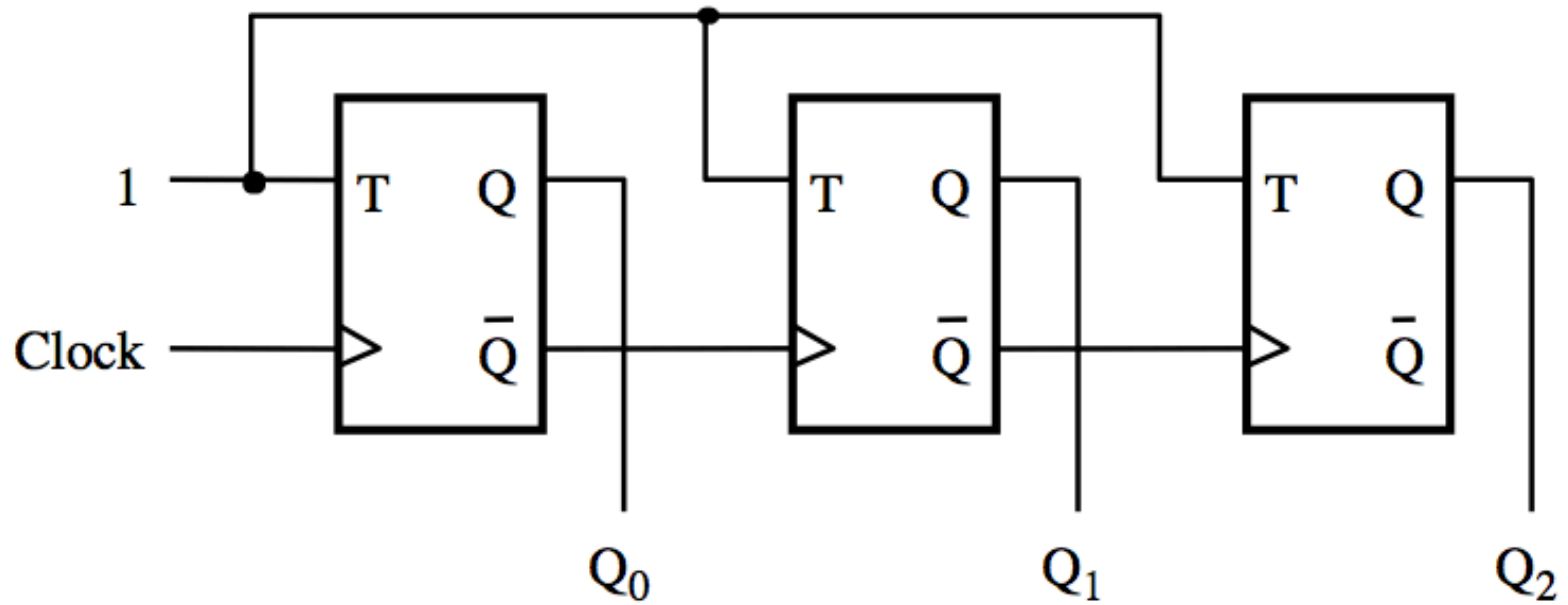

A three-bit up-counter

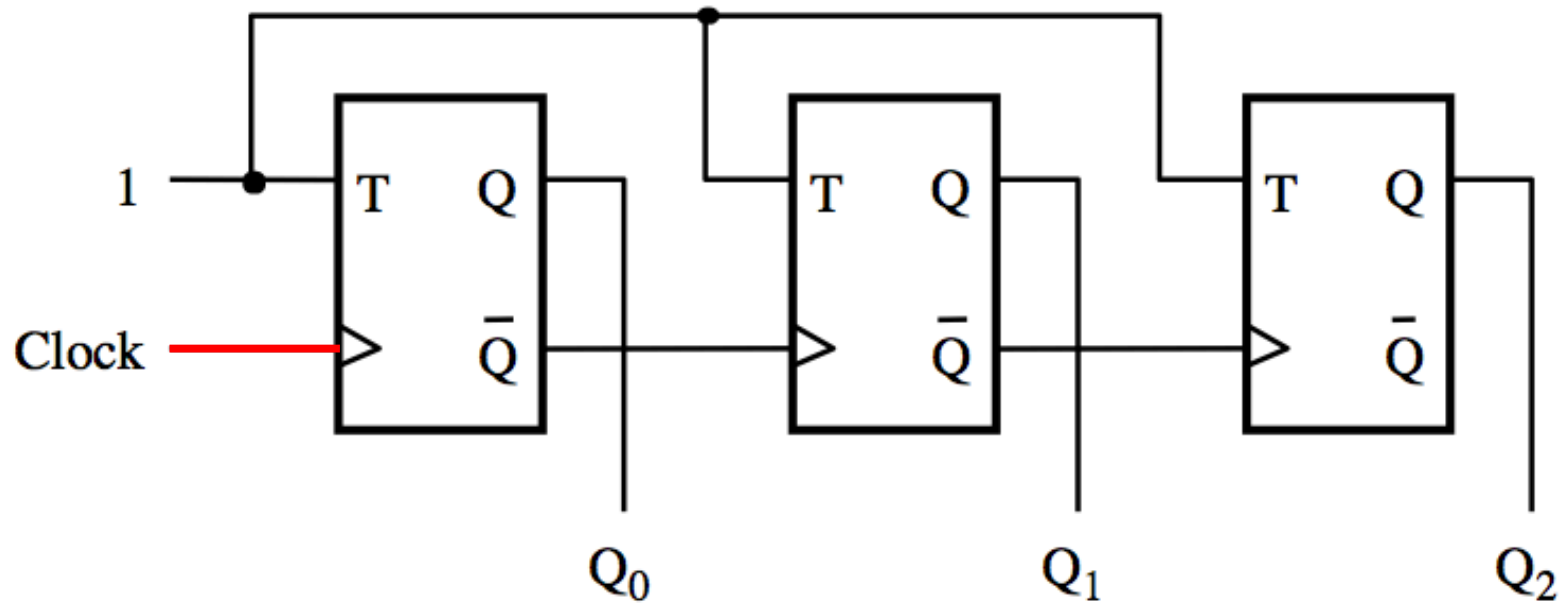

The first flip-flop changes
on the positive edge of the clock

A three-bit up-counter

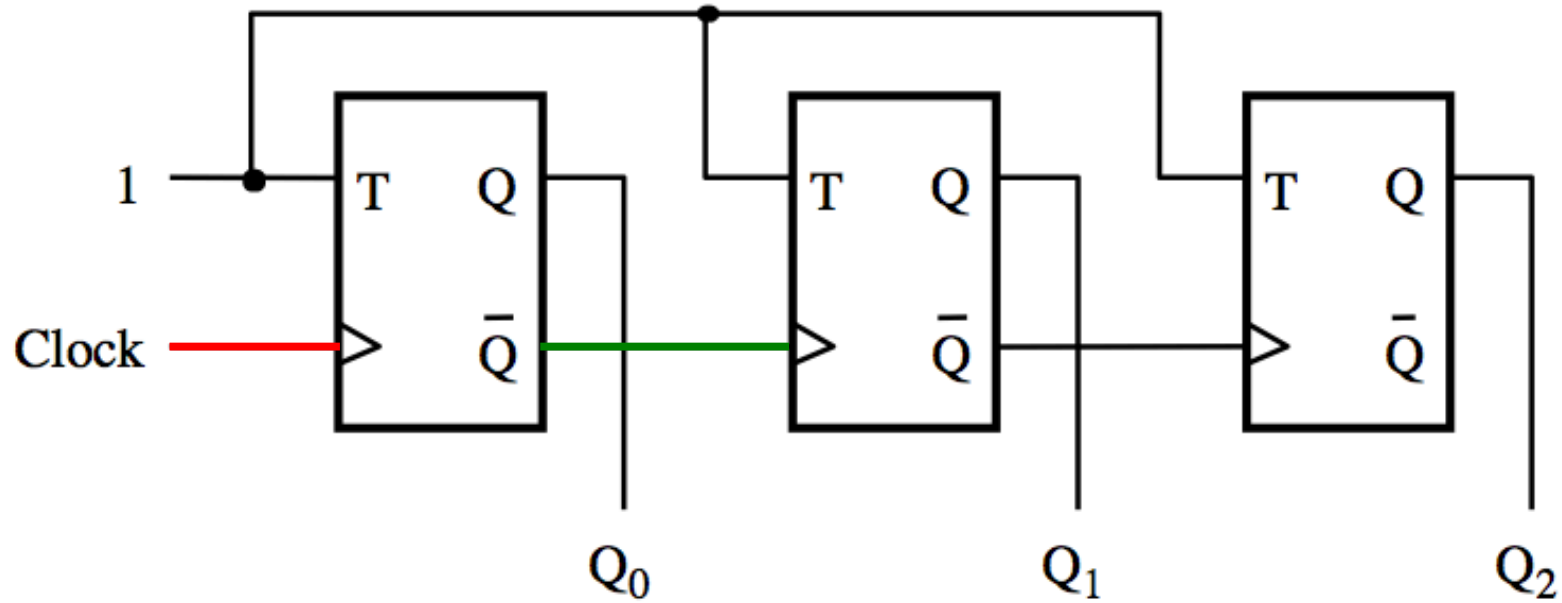

The first flip-flop changes
on the positive edge of the clock

The second flip-flop changes
on the positive edge of \bar{Q}_0

A three-bit up-counter

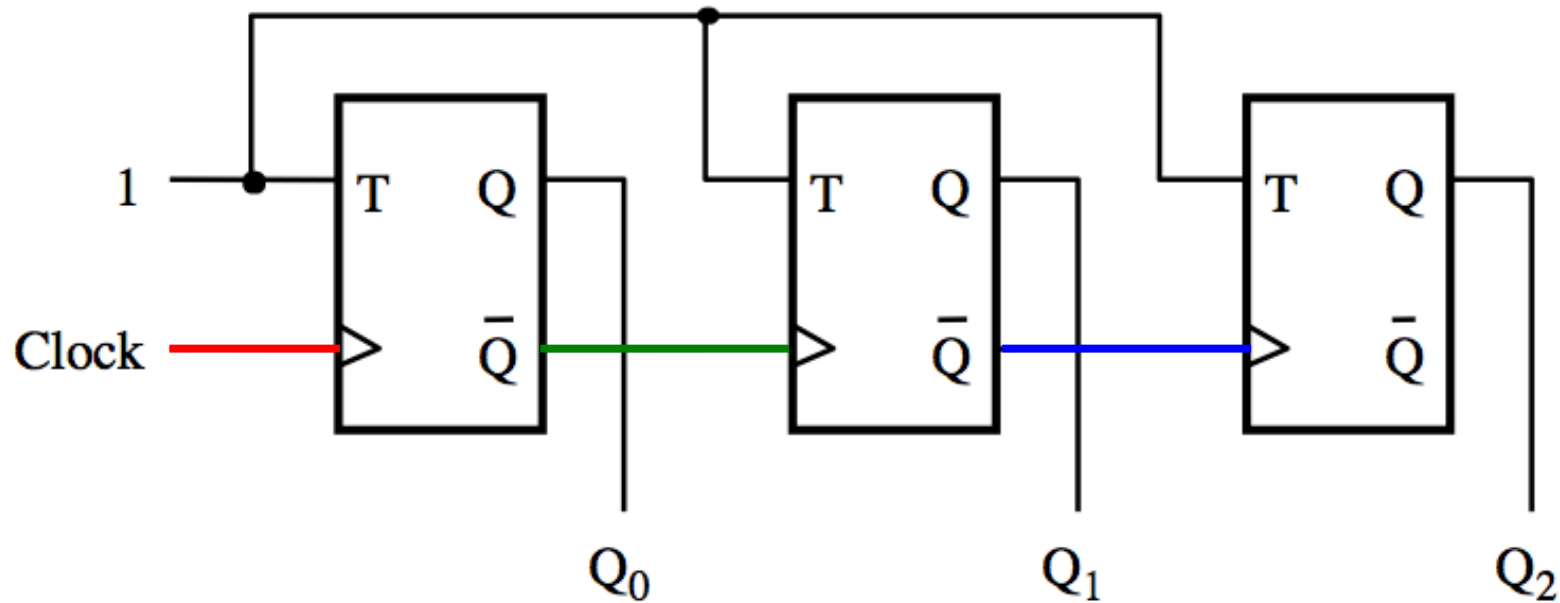

The first flip-flop changes
on the positive edge of the clock

The second flip-flop changes
on the positive edge of \bar{Q}_0

The third flip-flop changes
on the positive edge of \bar{Q}_1

A three-bit up-counter

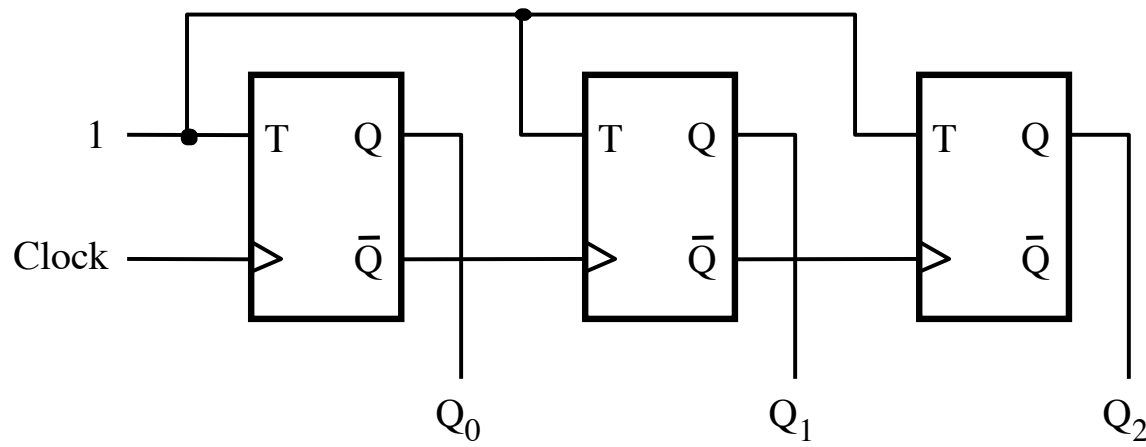

(a) Circuit

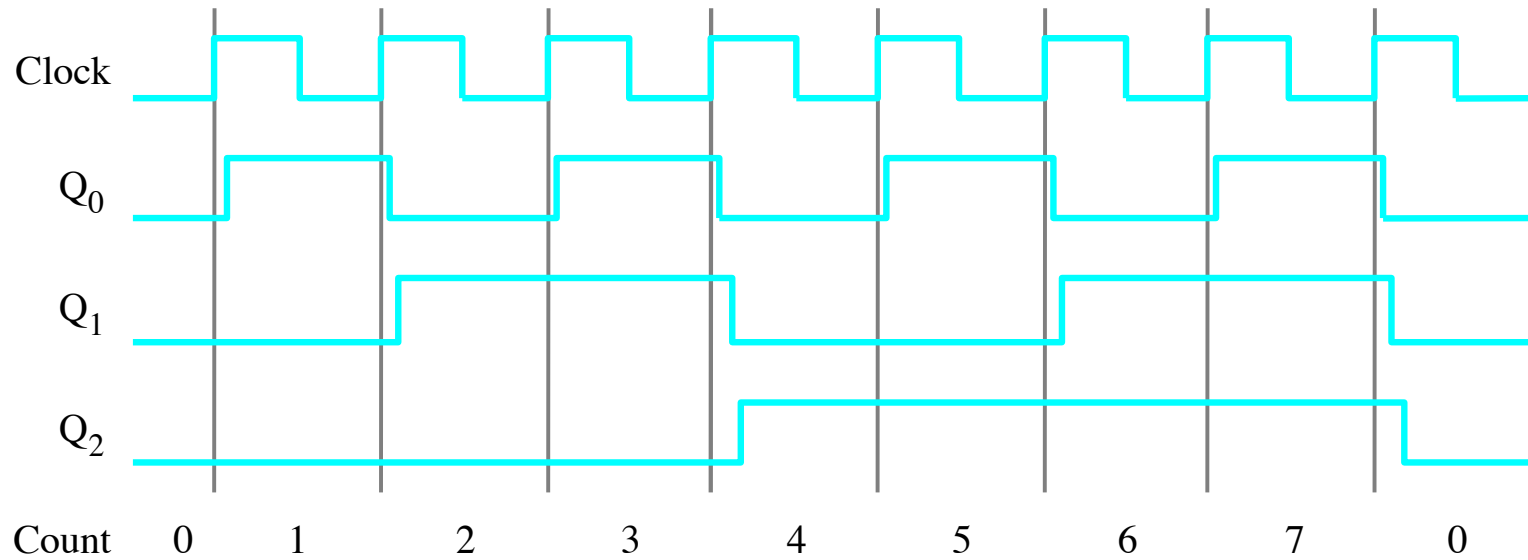

(b) Timing diagram

A three-bit up-counter

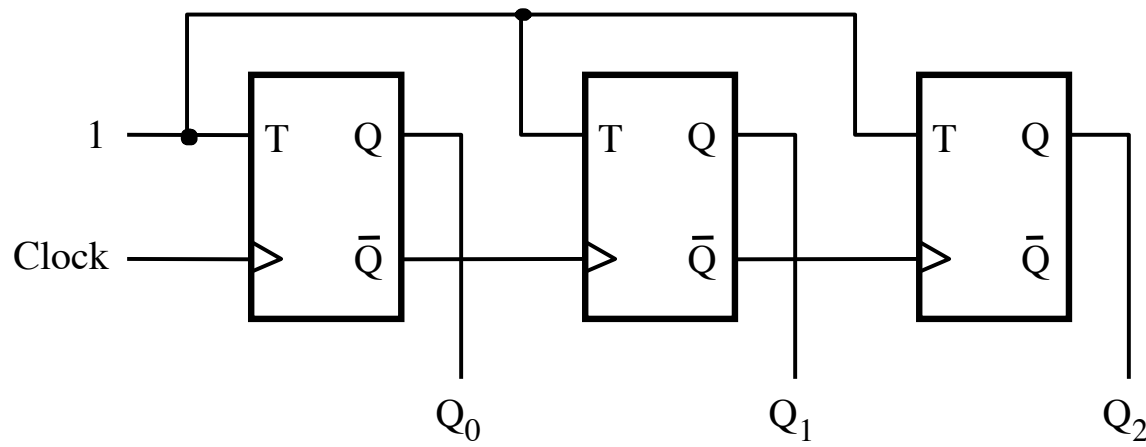

(a) Circuit

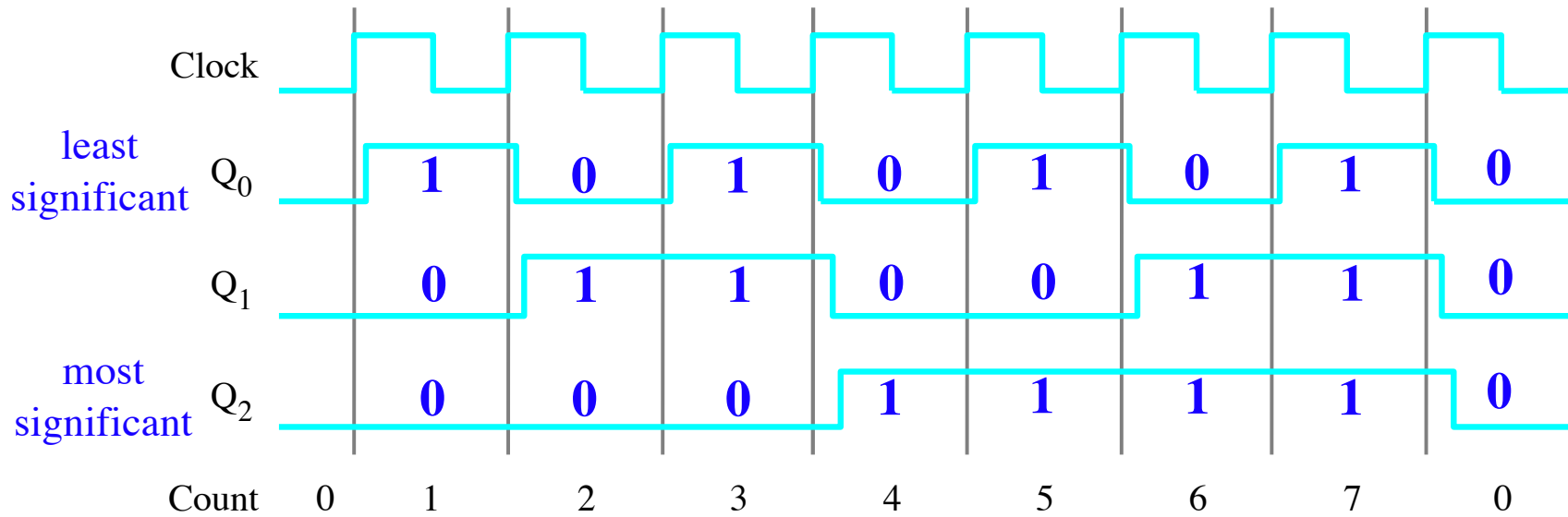

(b) Timing diagram

A three-bit up-counter

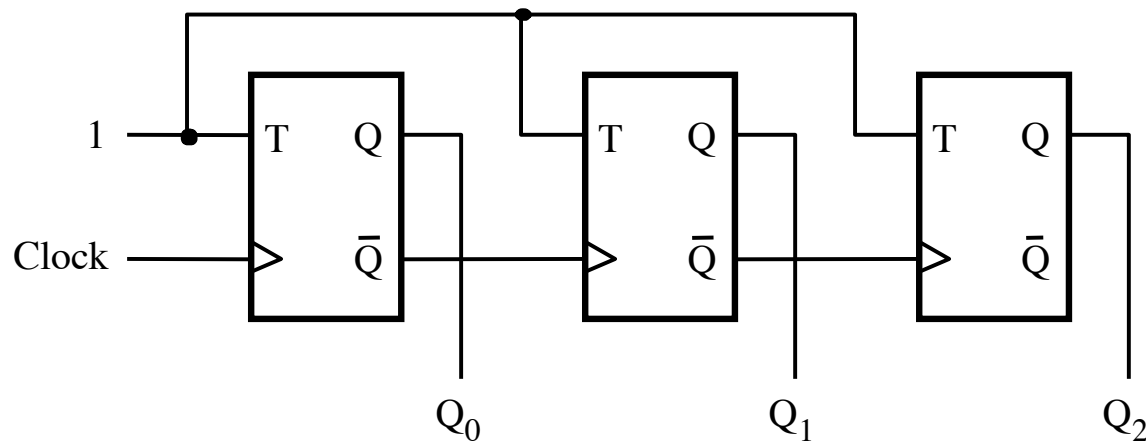

(a) Circuit

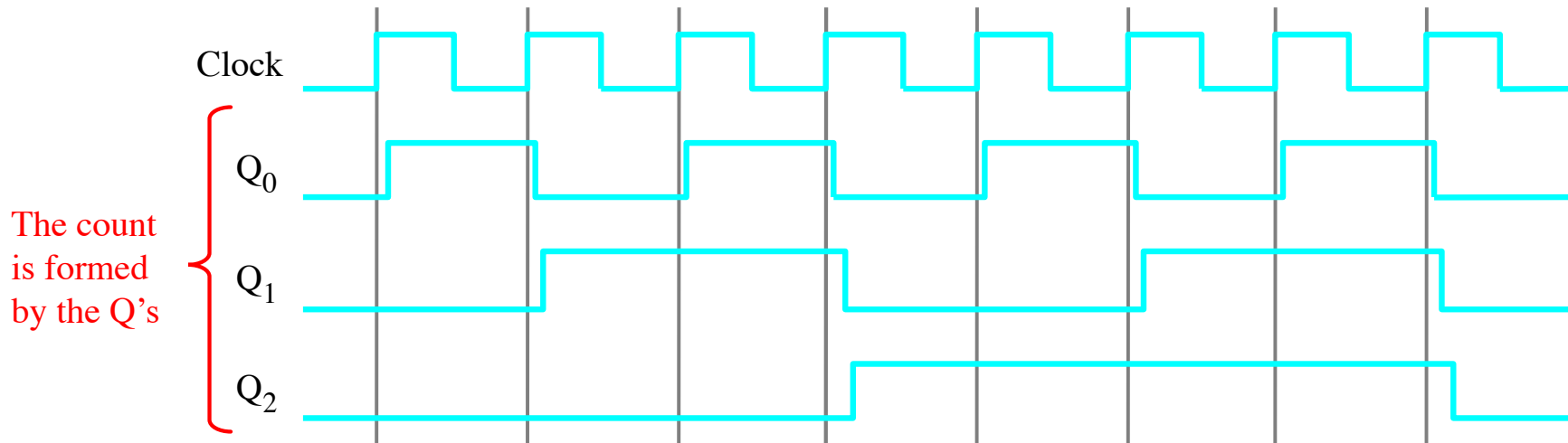

(b) Timing diagram

A three-bit up-counter

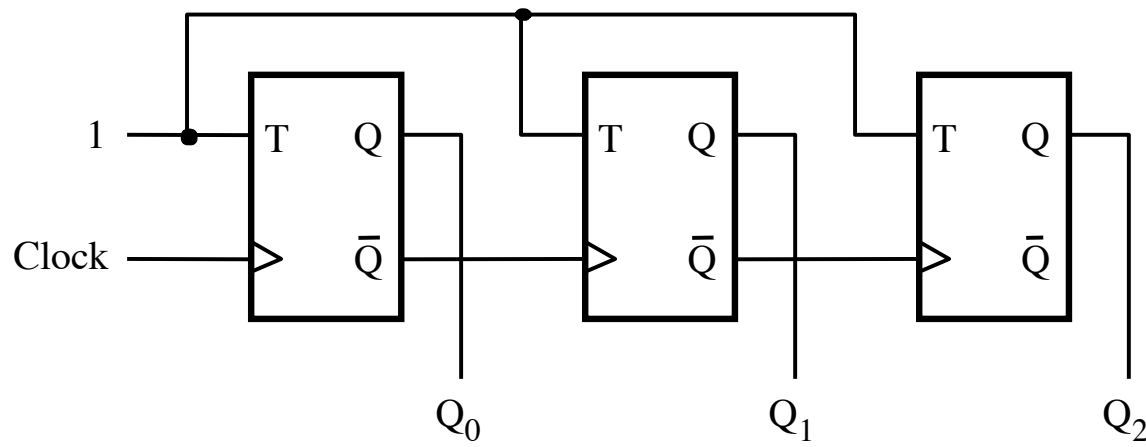

(a) Circuit

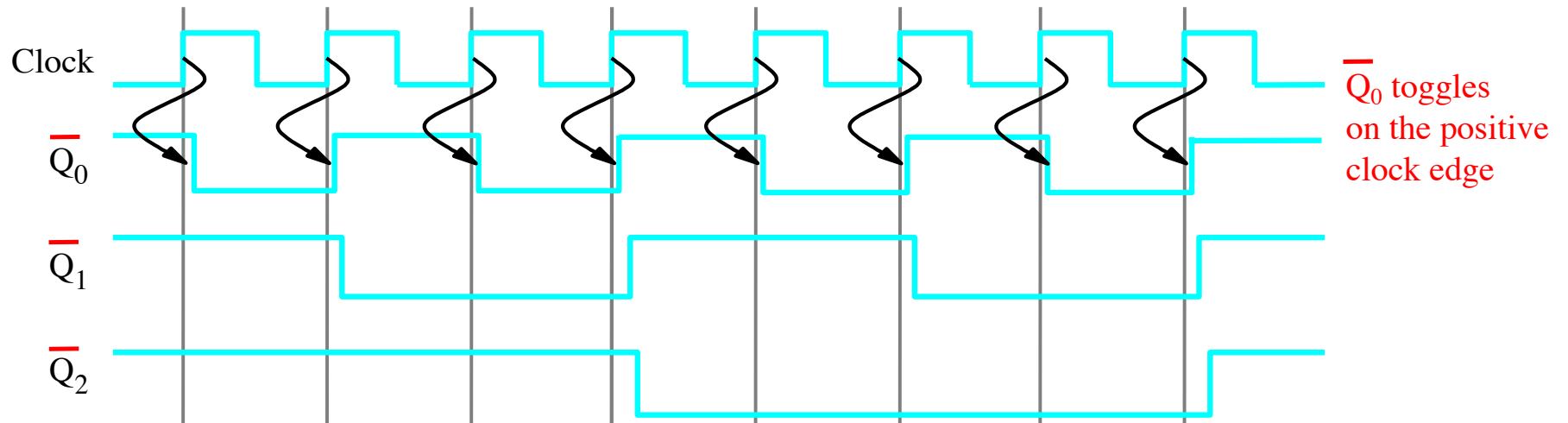

(b) Timing diagram

A three-bit up-counter

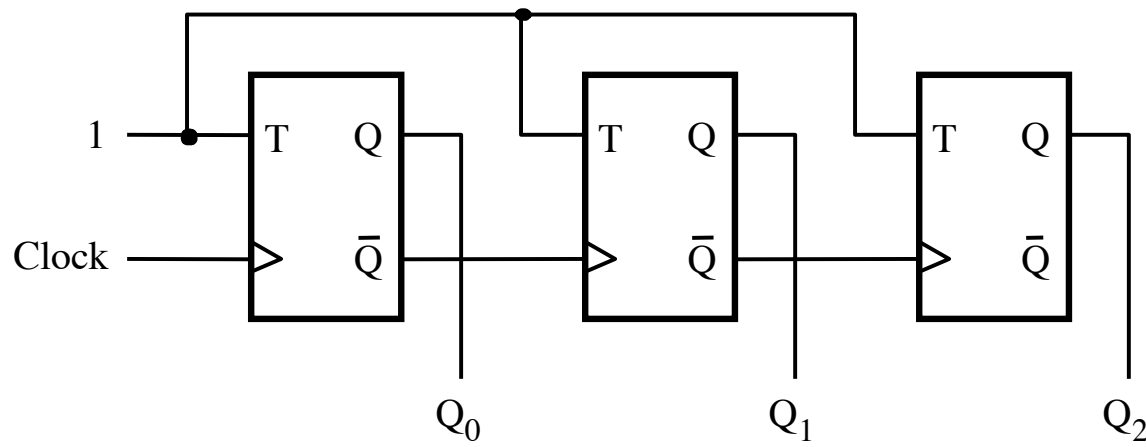

(a) Circuit

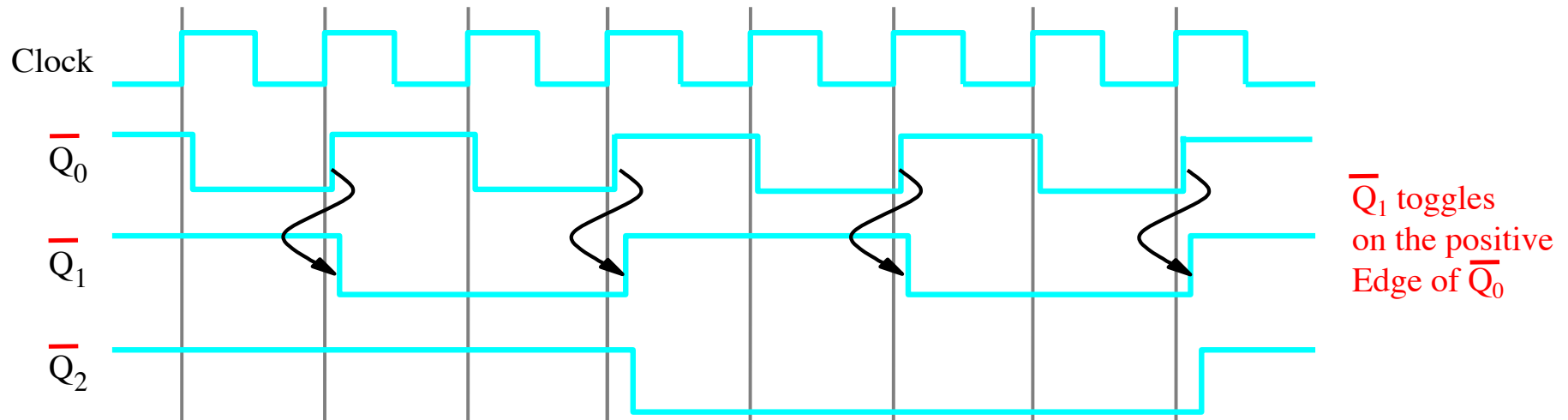

(b) Timing diagram

A three-bit up-counter

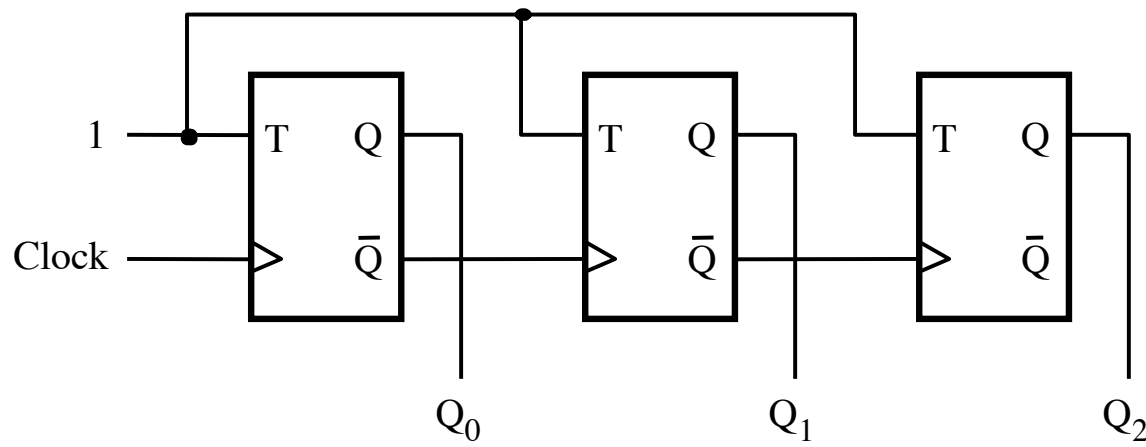

(a) Circuit

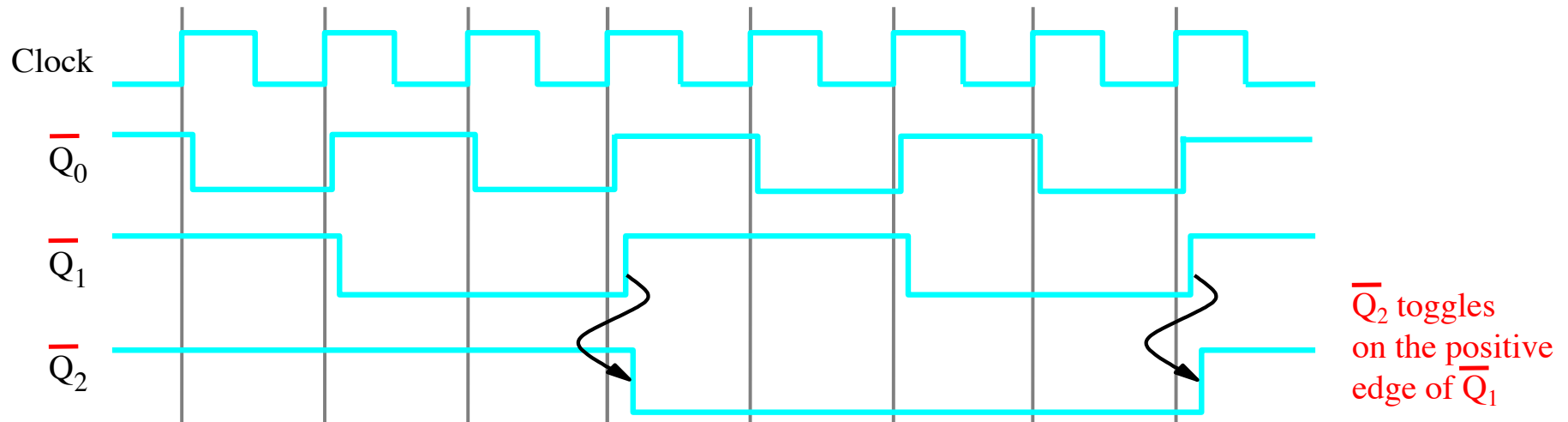

(b) Timing diagram

A three-bit up-counter

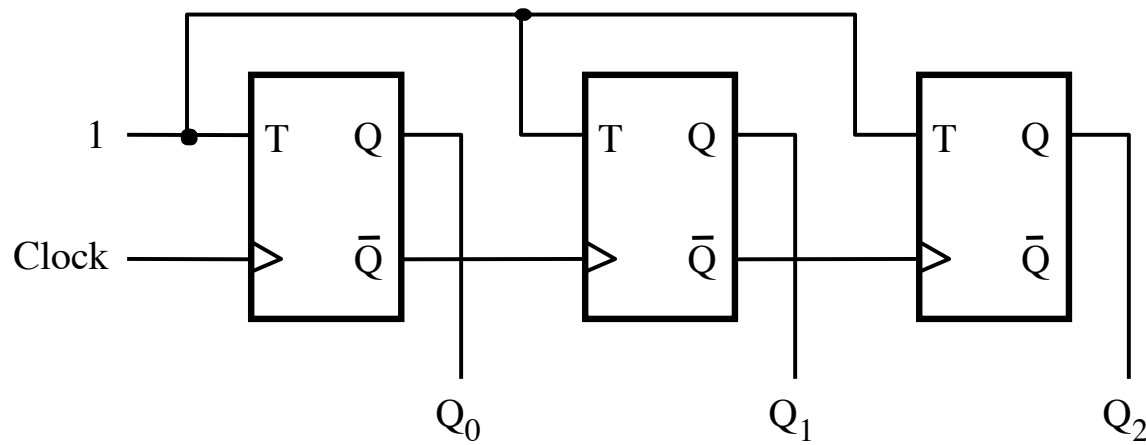

(a) Circuit **The propagation delays get longer**

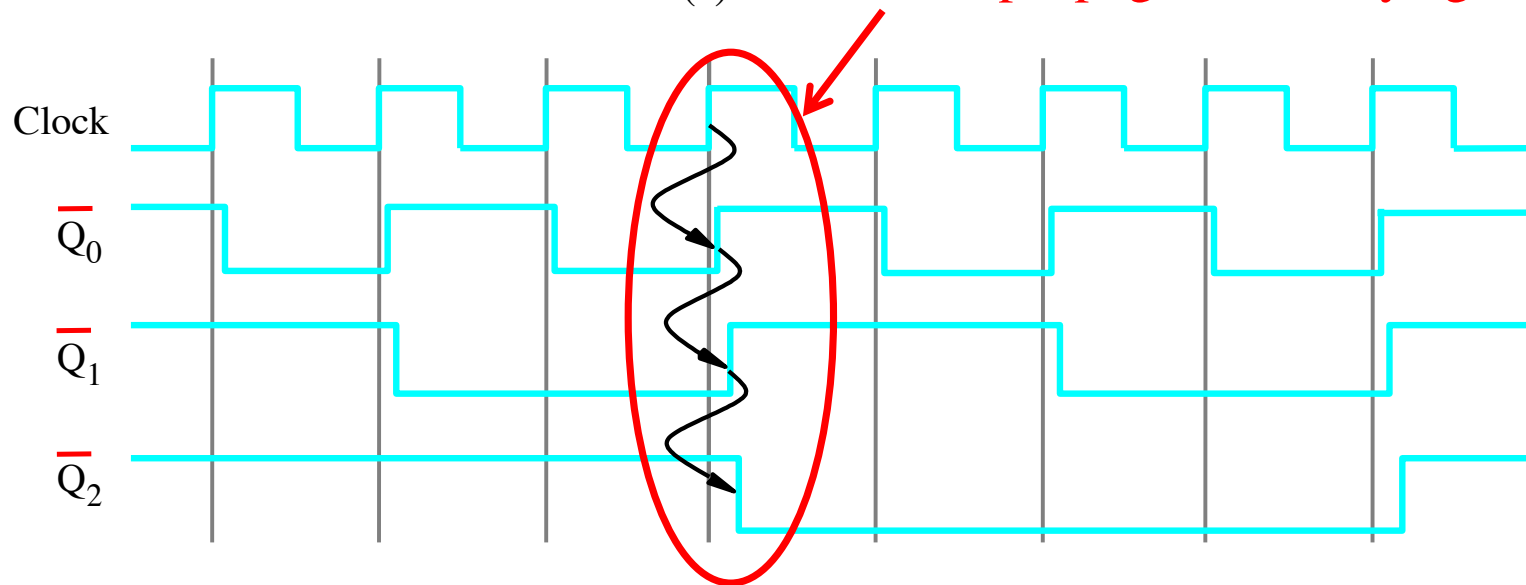

(b) Timing diagram

A three-bit up-counter

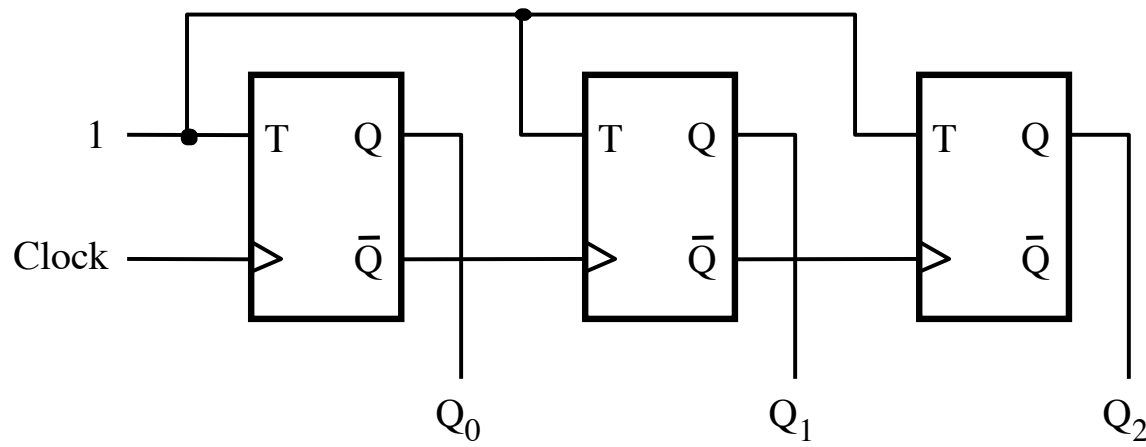

(a) Circuit **The propagation delays get longer**

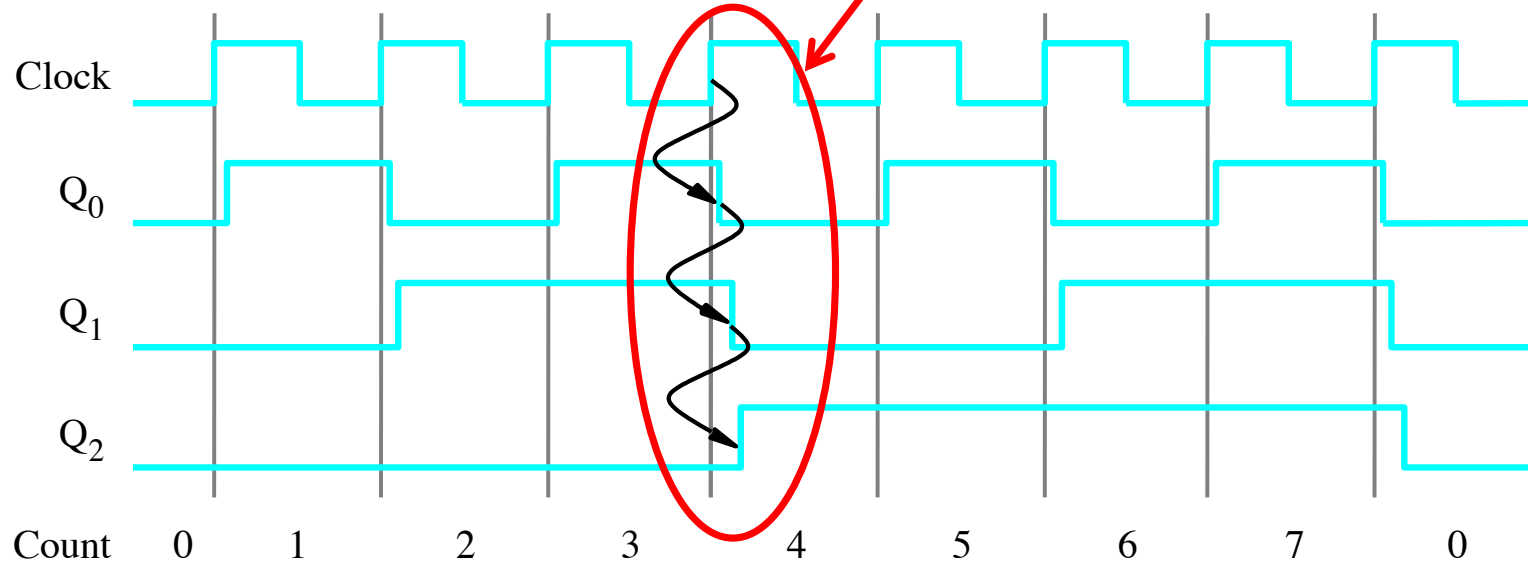

(b) Timing diagram

Synchronous Counters

A four-bit synchronous up-counter

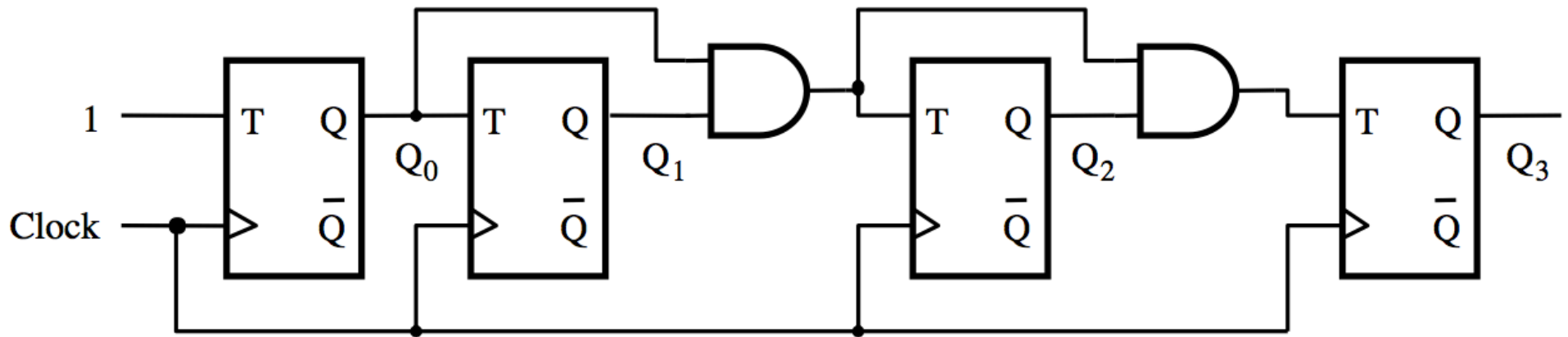

A four-bit synchronous up-counter

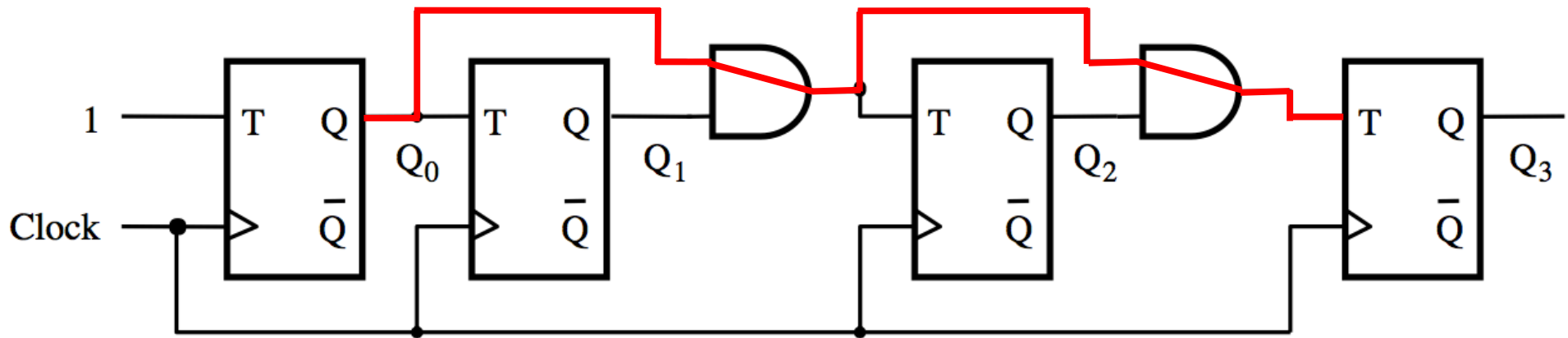

The propagation delay through all AND gates combined must not exceed the clock period minus the setup time for the flip-flops

A four-bit synchronous up-counter

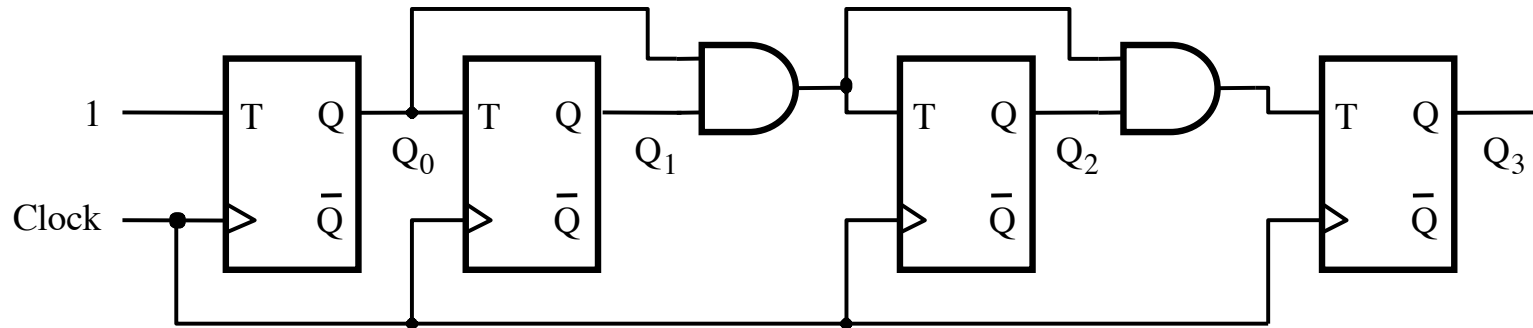

(a) Circuit

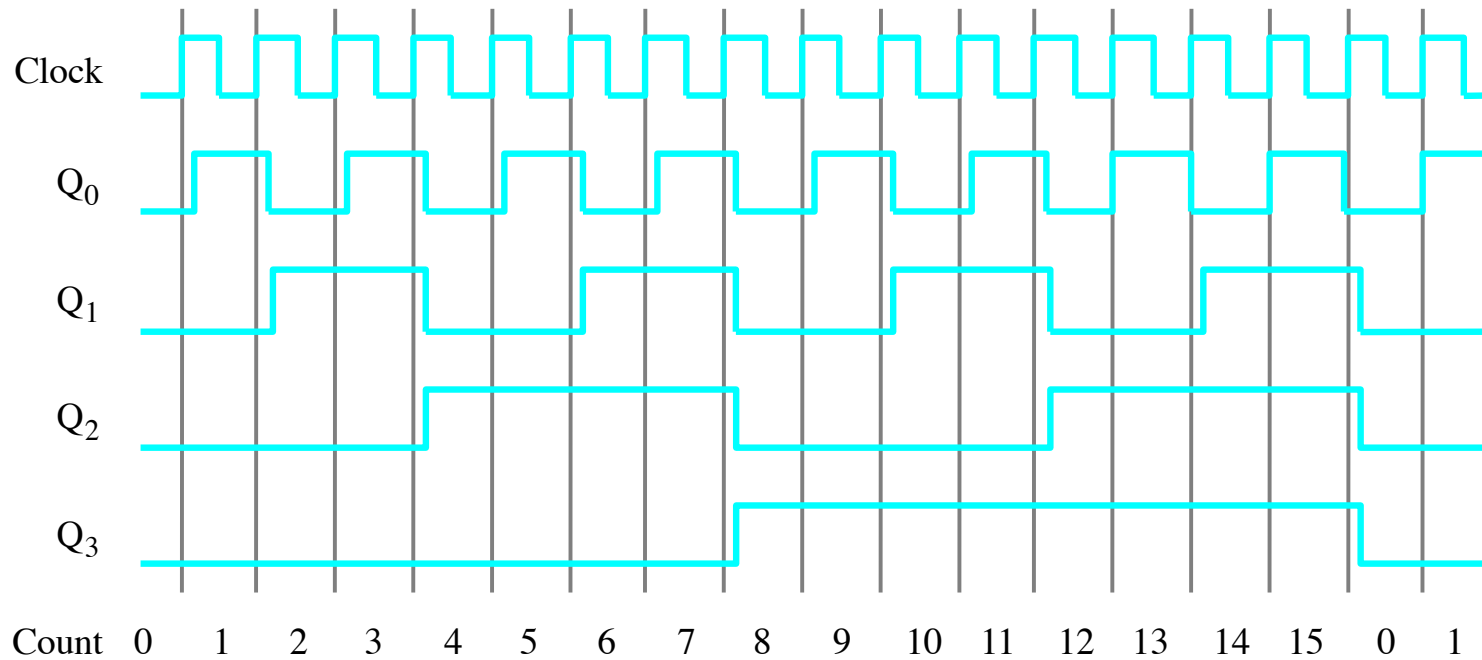

(b) Timing diagram

Derivation of the synchronous up-counter

Clock cycle	Q ₂	Q ₁	Q ₀
0	0	0	0
1	0	0	1
2	0	1	0
3	0	1	1
4	1	0	0
5	1	0	1
6	1	1	0
7	1	1	1
8	0	0	0

Q₁ changes

Q₂ changes

Derivation of the synchronous up-counter

Clock cycle	Q ₂	Q ₁	Q ₀
0	0	0	0
1	0	0	1
2	0	1	0
3	0	1	1
4	1	0	0
5	1	0	1
6	1	1	0
7	1	1	1
8	0	0	0

Q₁ changes

Q₂ changes

$$T_0 = 1$$

$$T_1 = Q_0$$

$$T_2 = Q_0 Q_1$$

A four-bit synchronous up-counter

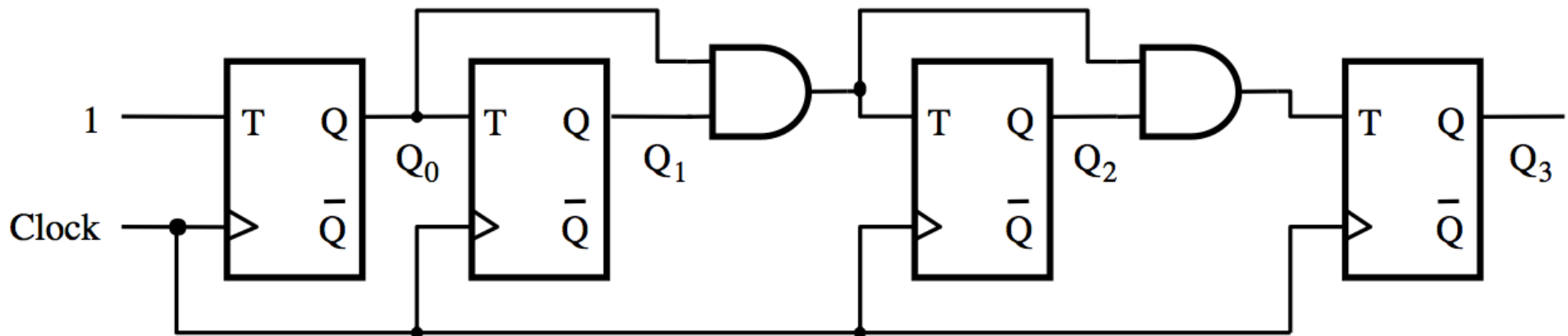

$$T_0 = 1$$

$$T_1 = Q_0$$

$$T_2 = Q_0 Q_1$$

In general we have

$$T_0 = 1$$

$$T_1 = Q_0$$

$$T_2 = Q_0 Q_1$$

$$T_3 = Q_0 Q_1 Q_2$$

...

$$T_n = Q_0 Q_1 Q_2 \cdots Q_{n-1}$$

Synchronous v.s. Asynchronous Clear

2-Bit Synchronous Up-Counter (without clear capability)

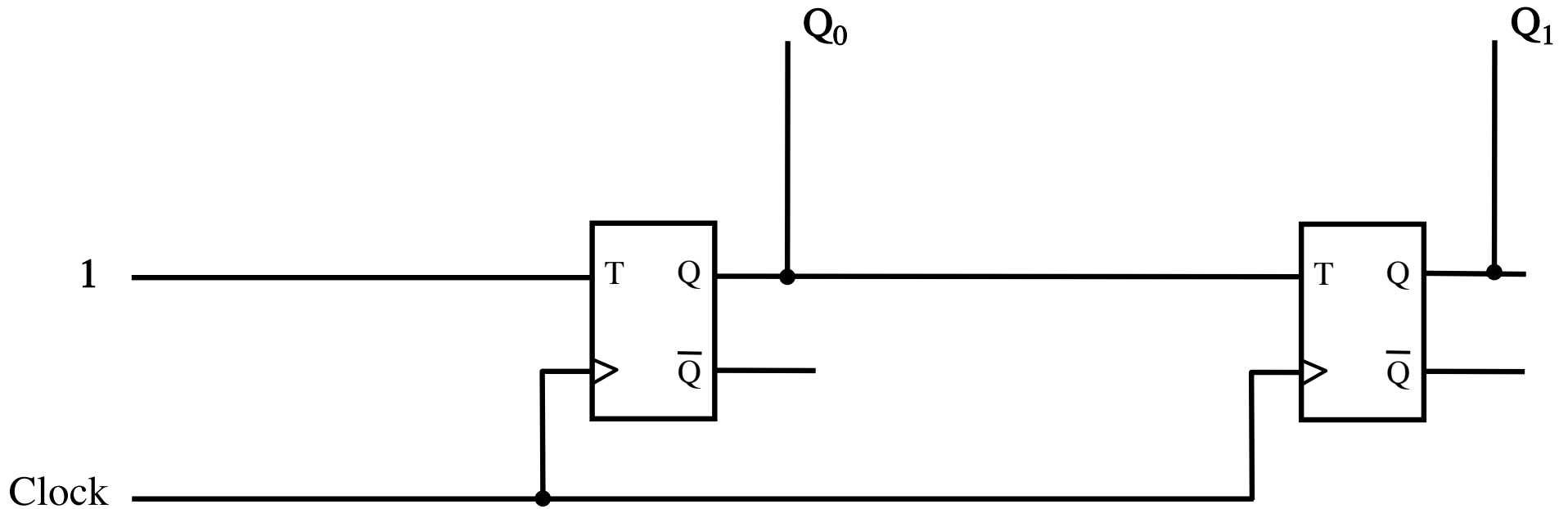

2-Bit Synchronous Up-Counter (with asynchronous clear)

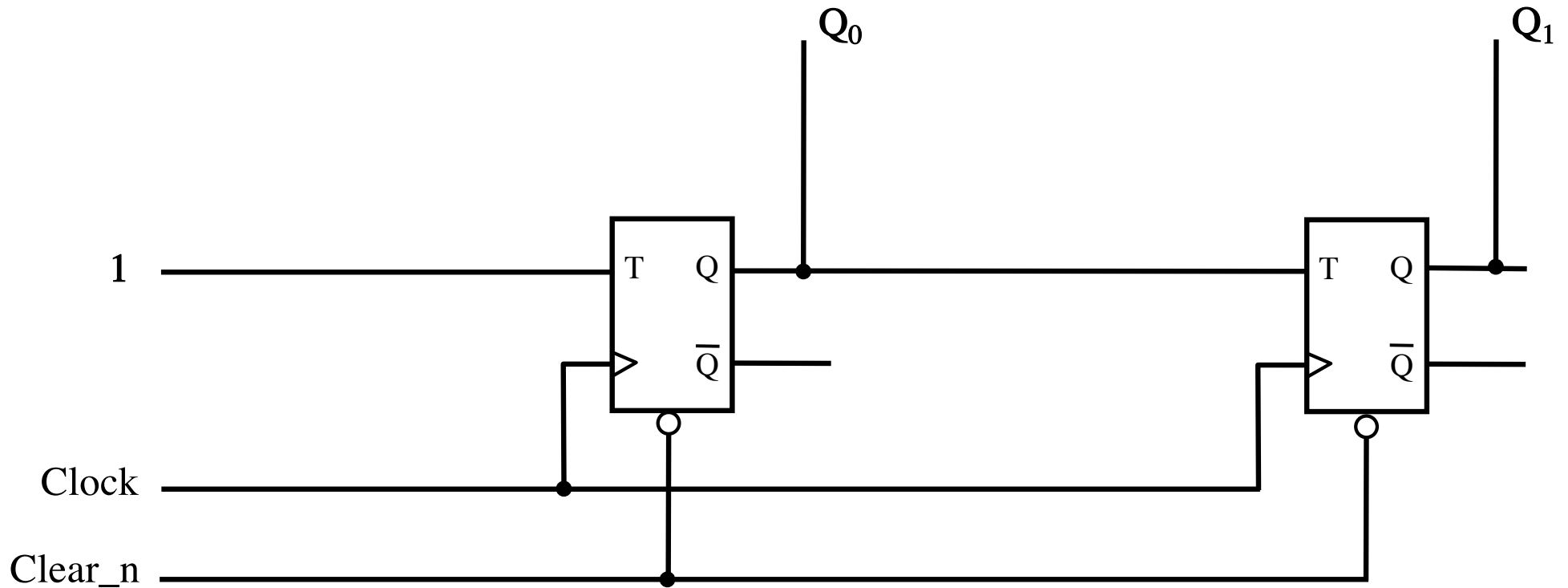

2-Bit Synchronous Up-Counter (with asynchronous clear)

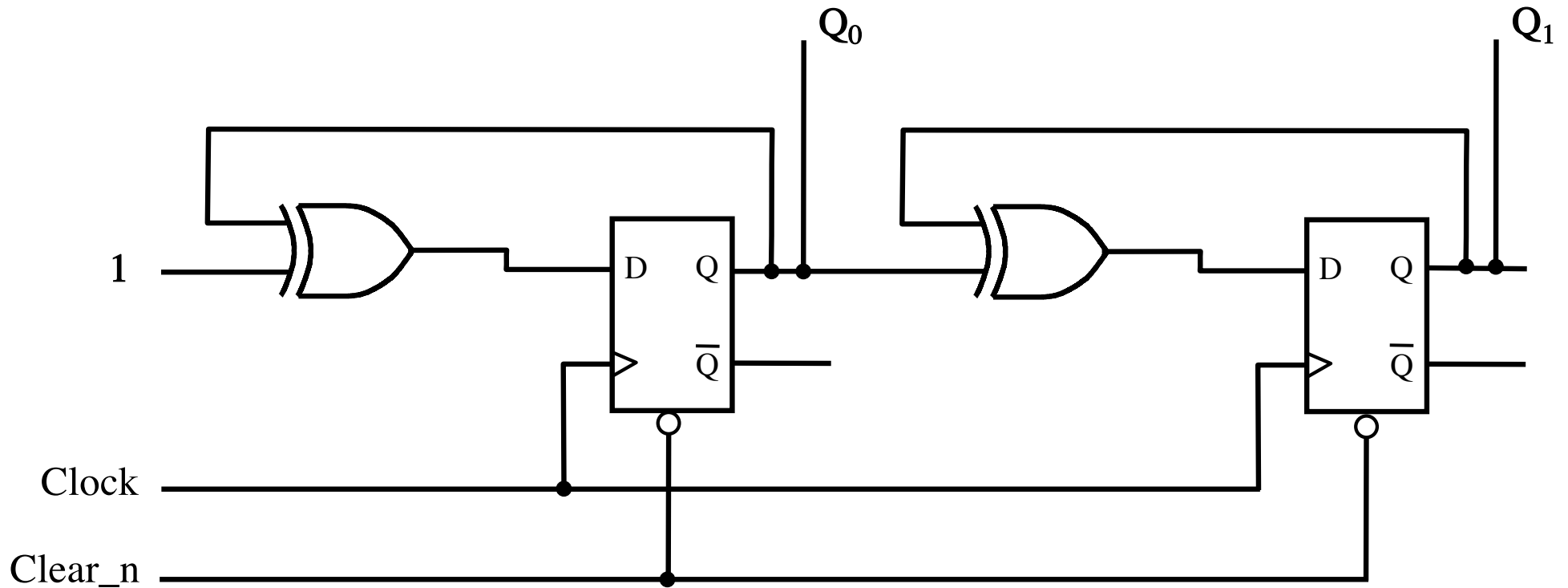

This is the same circuit but uses D Flip-Flops.

2-Bit Synchronous Up-Counter (with synchronous clear)

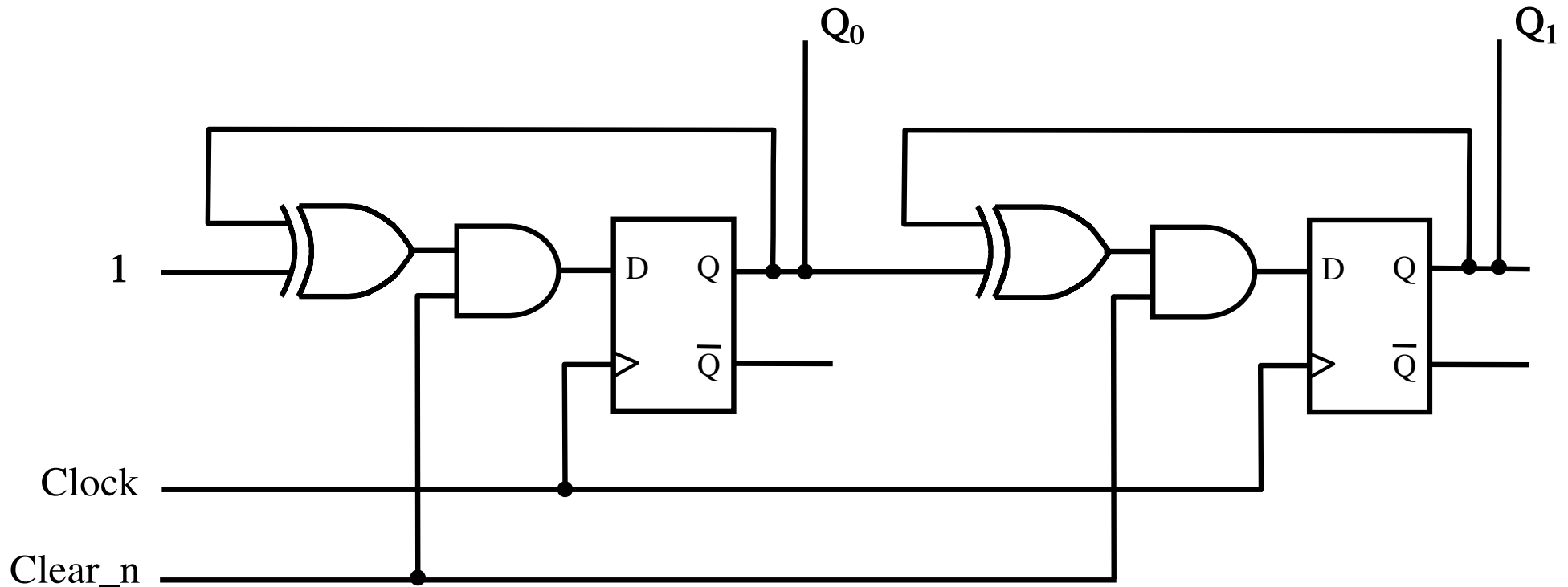

This counter can be cleared only on the positive clock edge.

Adding Enable Capability

A four-bit synchronous up-counter

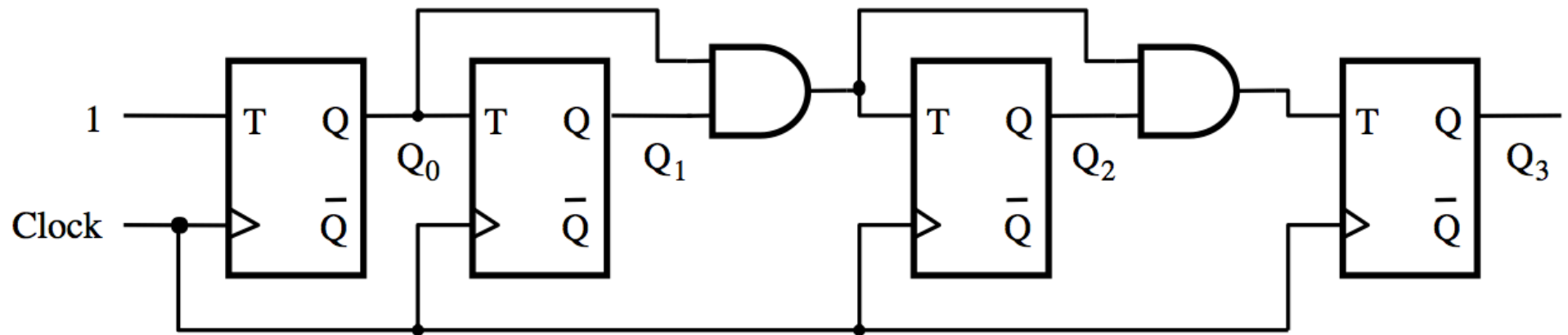

Inclusion of Enable and Clear Capability

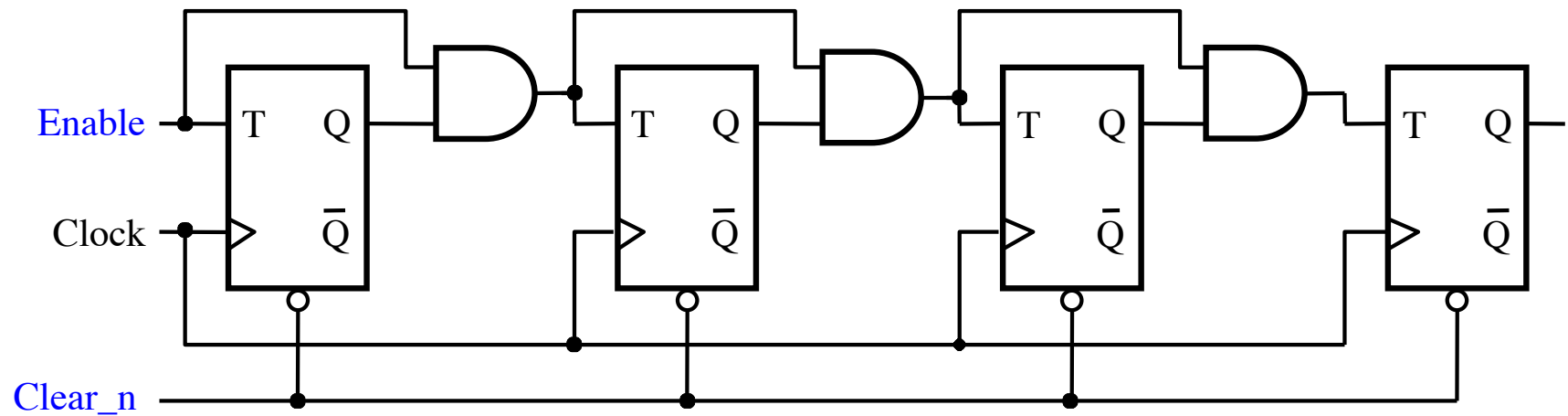

[Figure 5.22 from the textbook]

Inclusion of Enable and Clear Capability

This is the new thing relative to the previous figure, plus the clear_n line

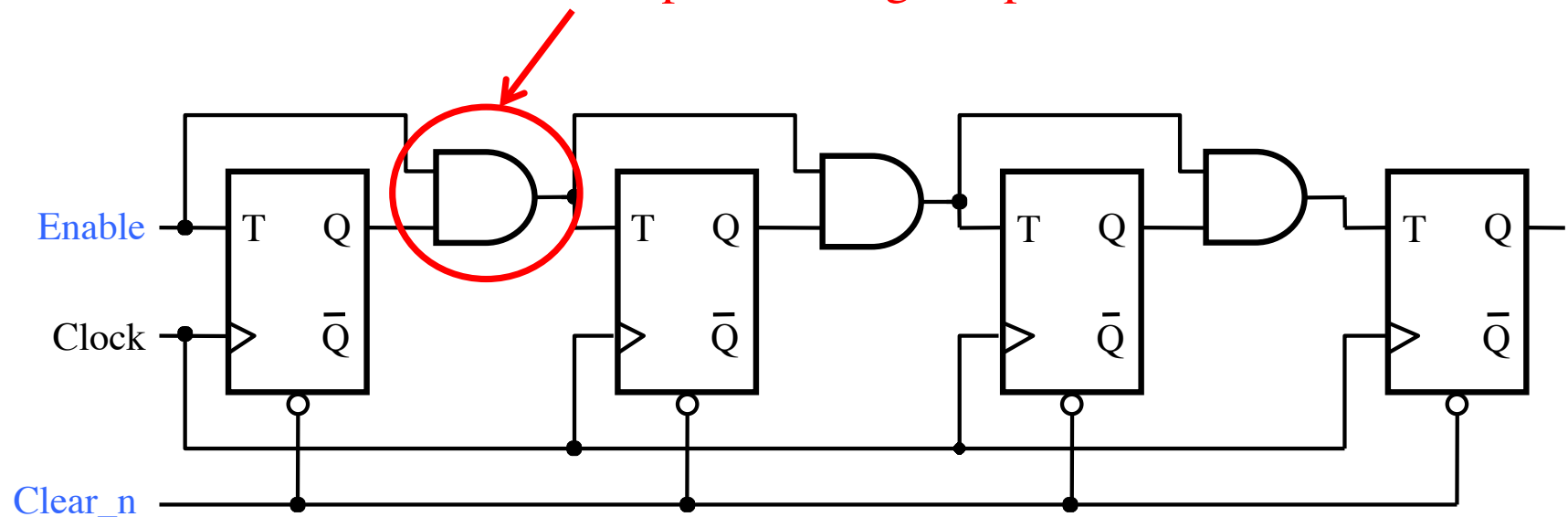

Providing an enable input for a D flip-flop

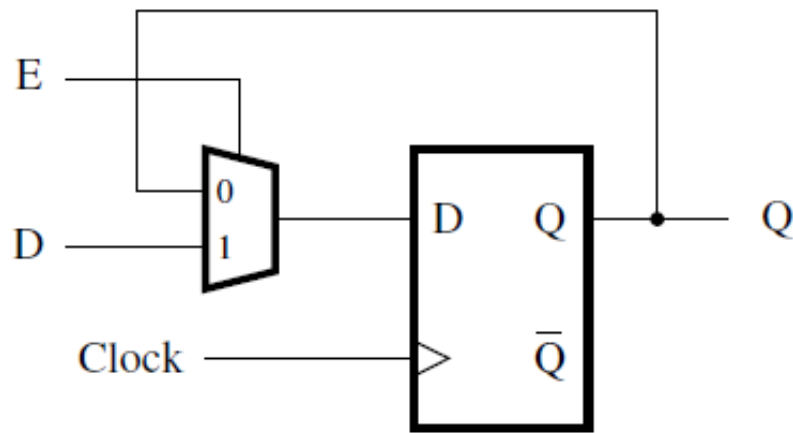

(a) Using a multiplexer

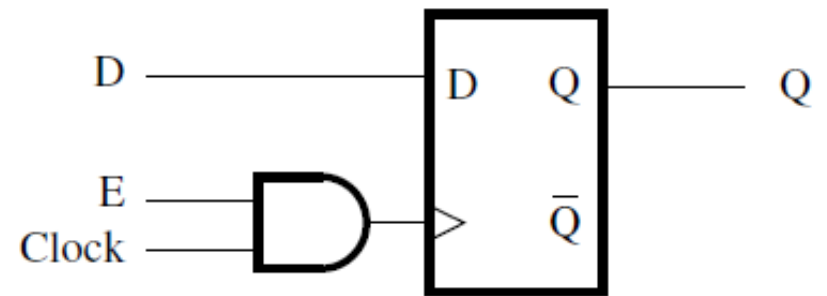

(b) Clock gating

Synchronous Counter (with D Flip-Flops)

A 4-bit up-counter with D flip-flops

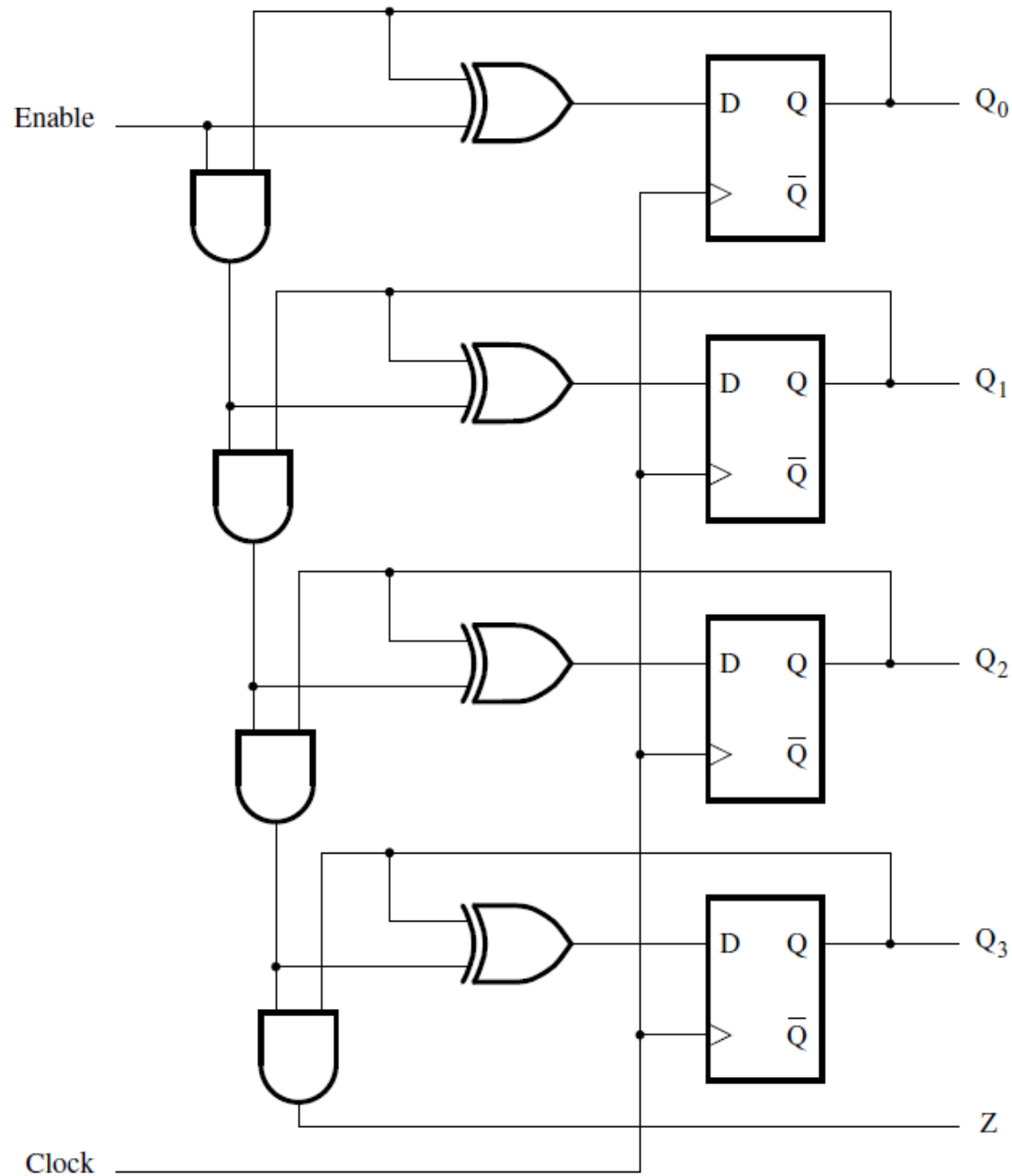

[Figure 5.23 from the textbook]

A 4-bit up-counter with D flip-flops

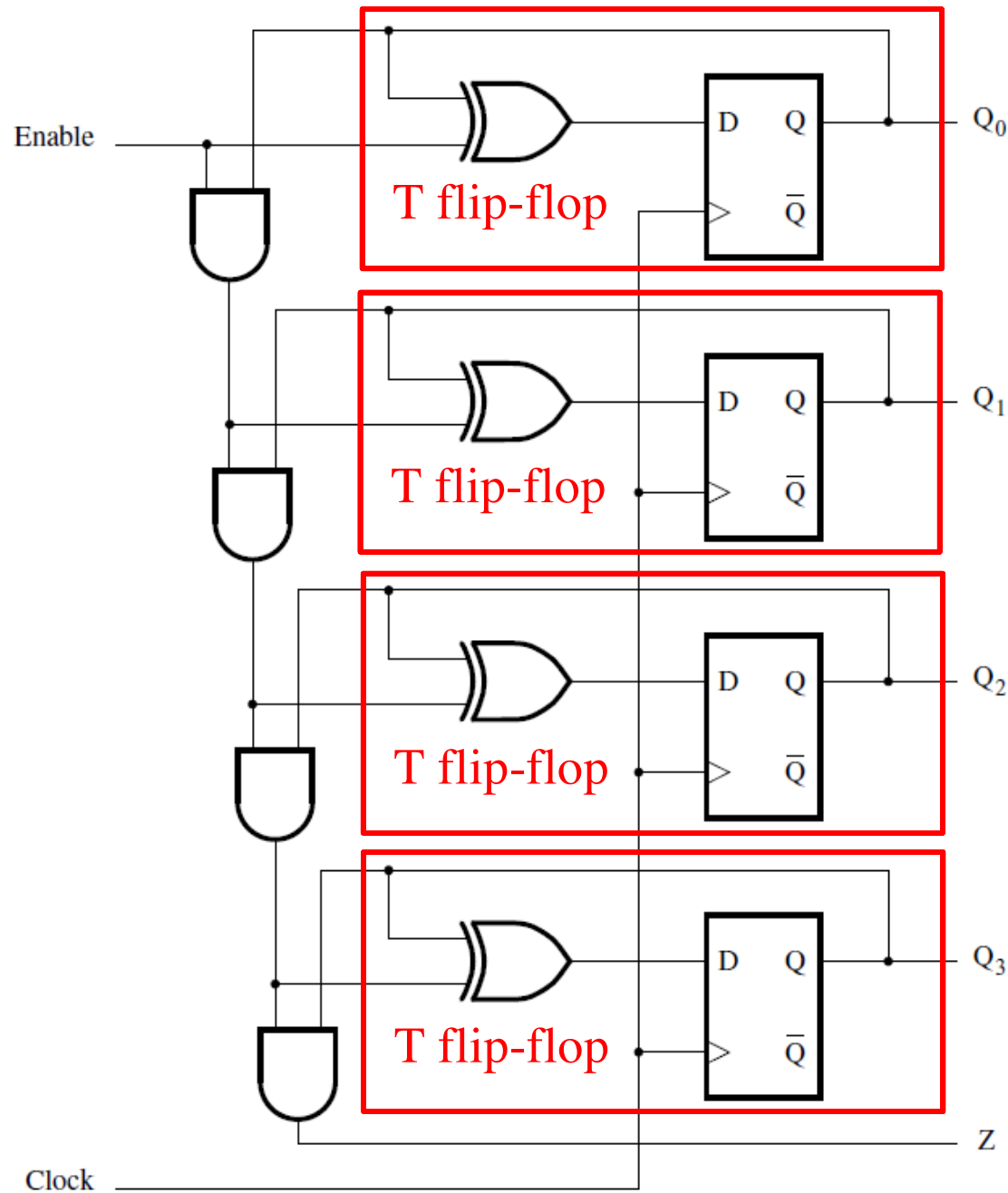

[Figure 5.23 from the textbook]

Equivalent to this circuit with T flip-flops

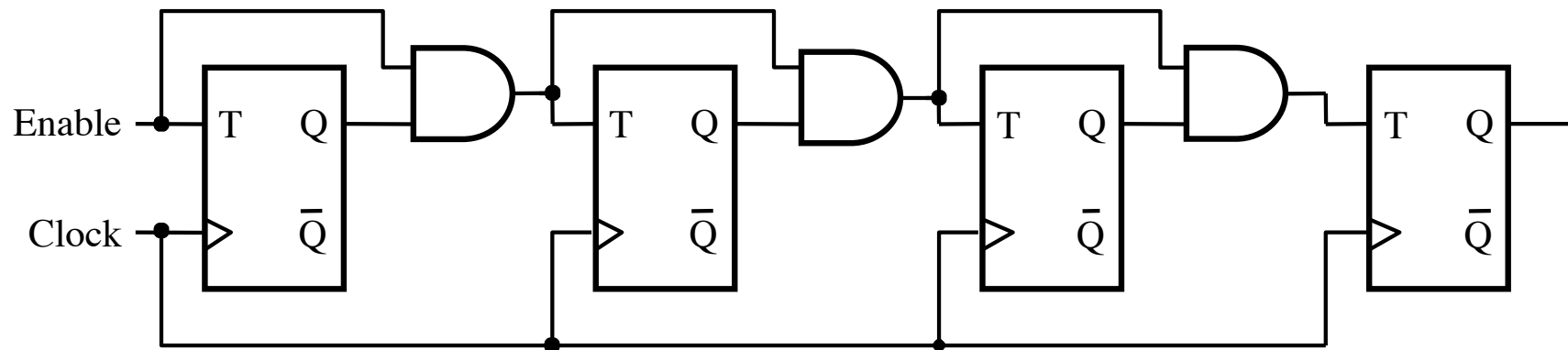

Equivalent to this circuit with T flip-flops

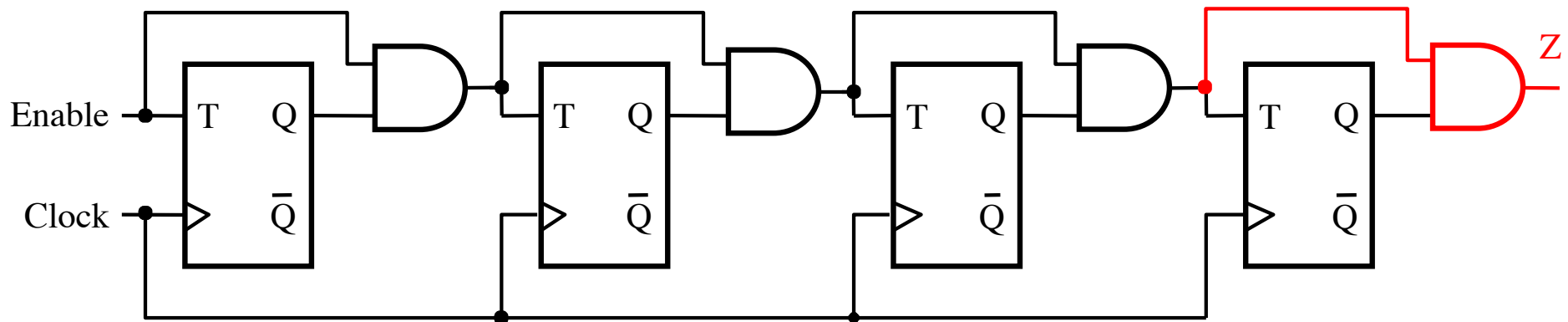

But has one extra output called Z, which can be used to connect two 4-bit counters to make an 8-bit counter.

When $Z=1$ the counter will go 0000 on the next clock edge, i.e., the outputs of all flip-flops are currently 1 (maximum count value).

Counters with Parallel Load

A counter with parallel-load capability

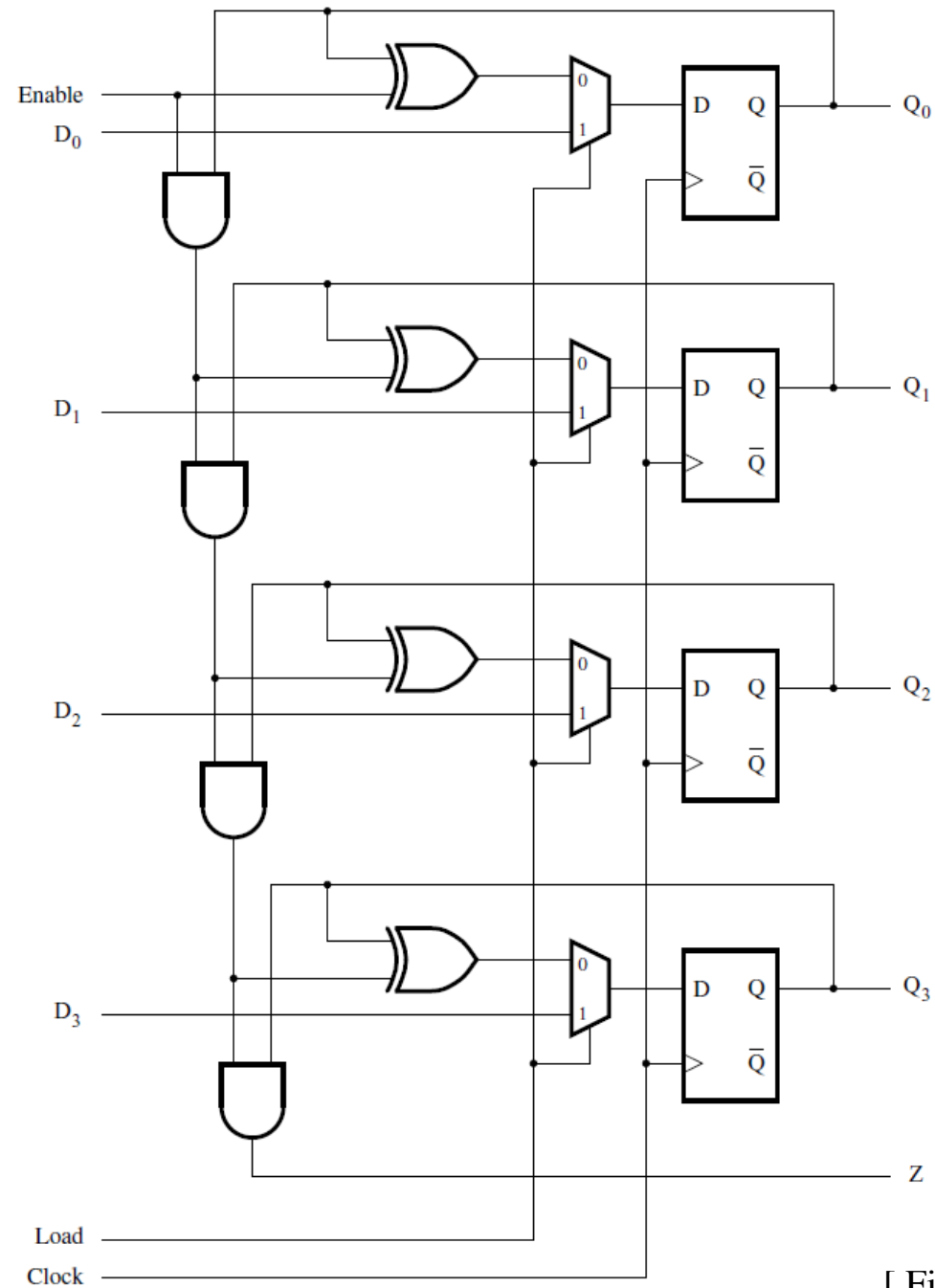

[Figure 5.24 from the textbook]

How to load the initial count value

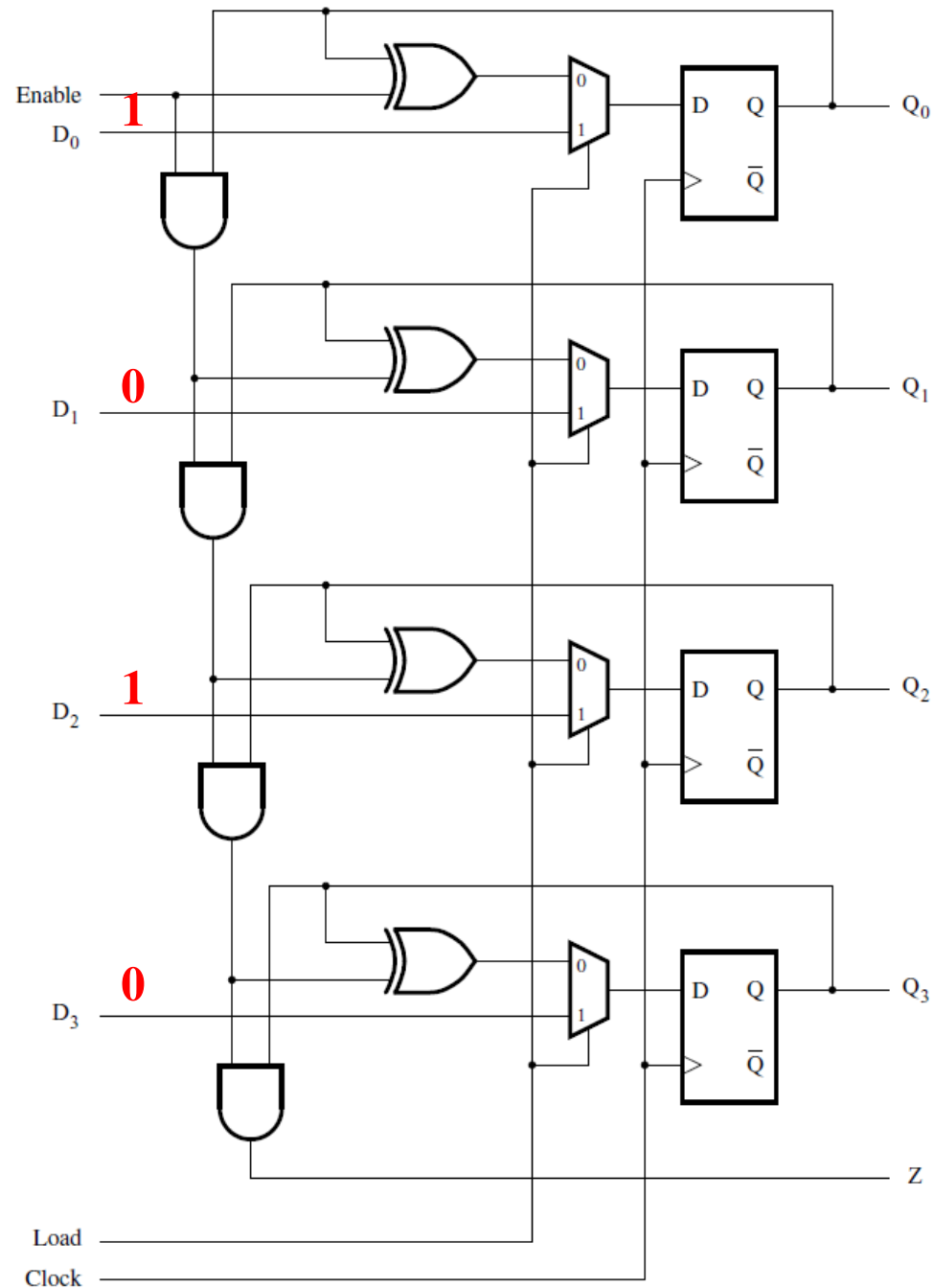

Set the initial count on
the parallel load lines
(in this case 5).

How to zero a counter

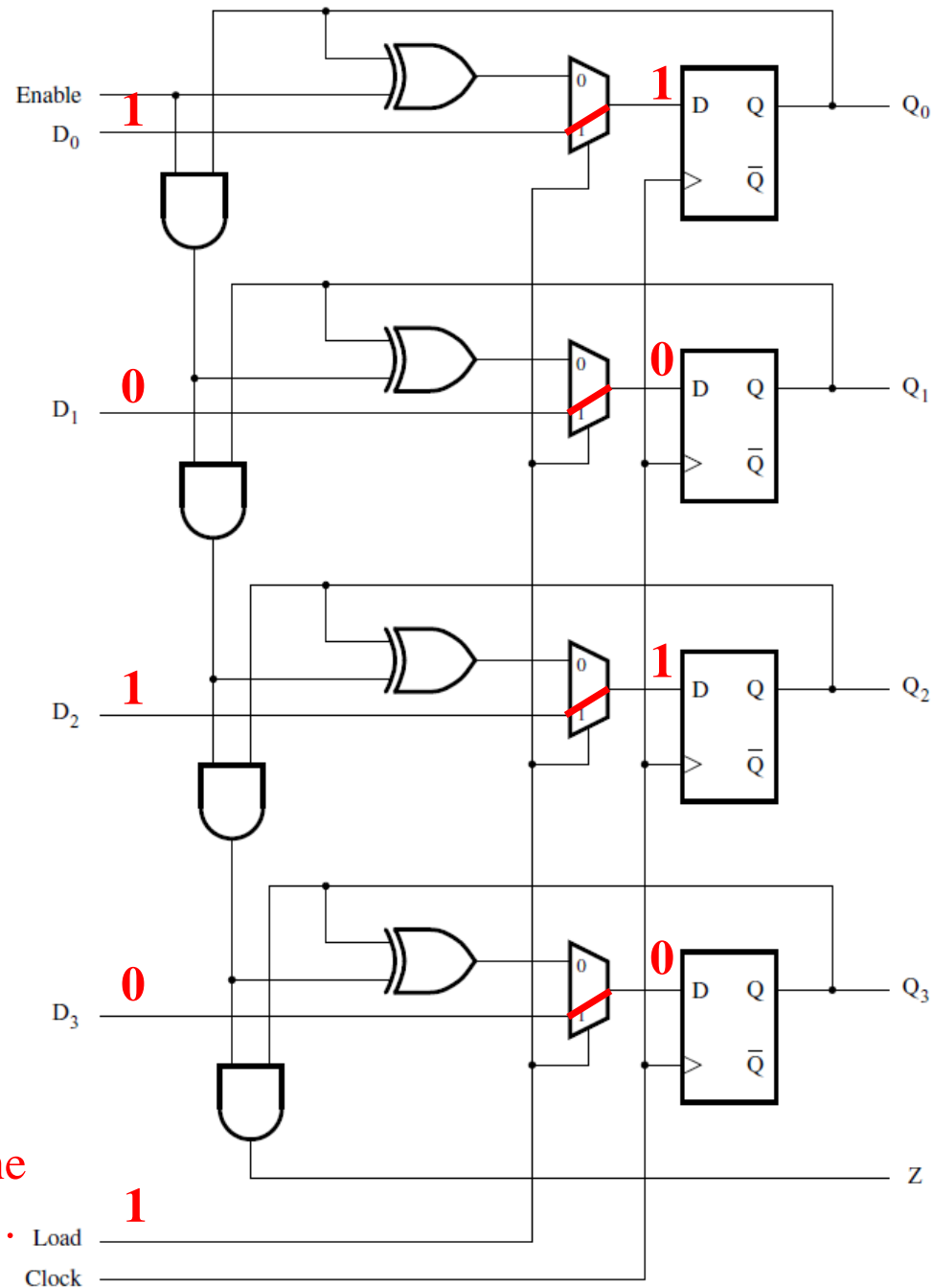

Set "Load" to 1, to open the "1" line of the multiplexers.

How to zero a counter

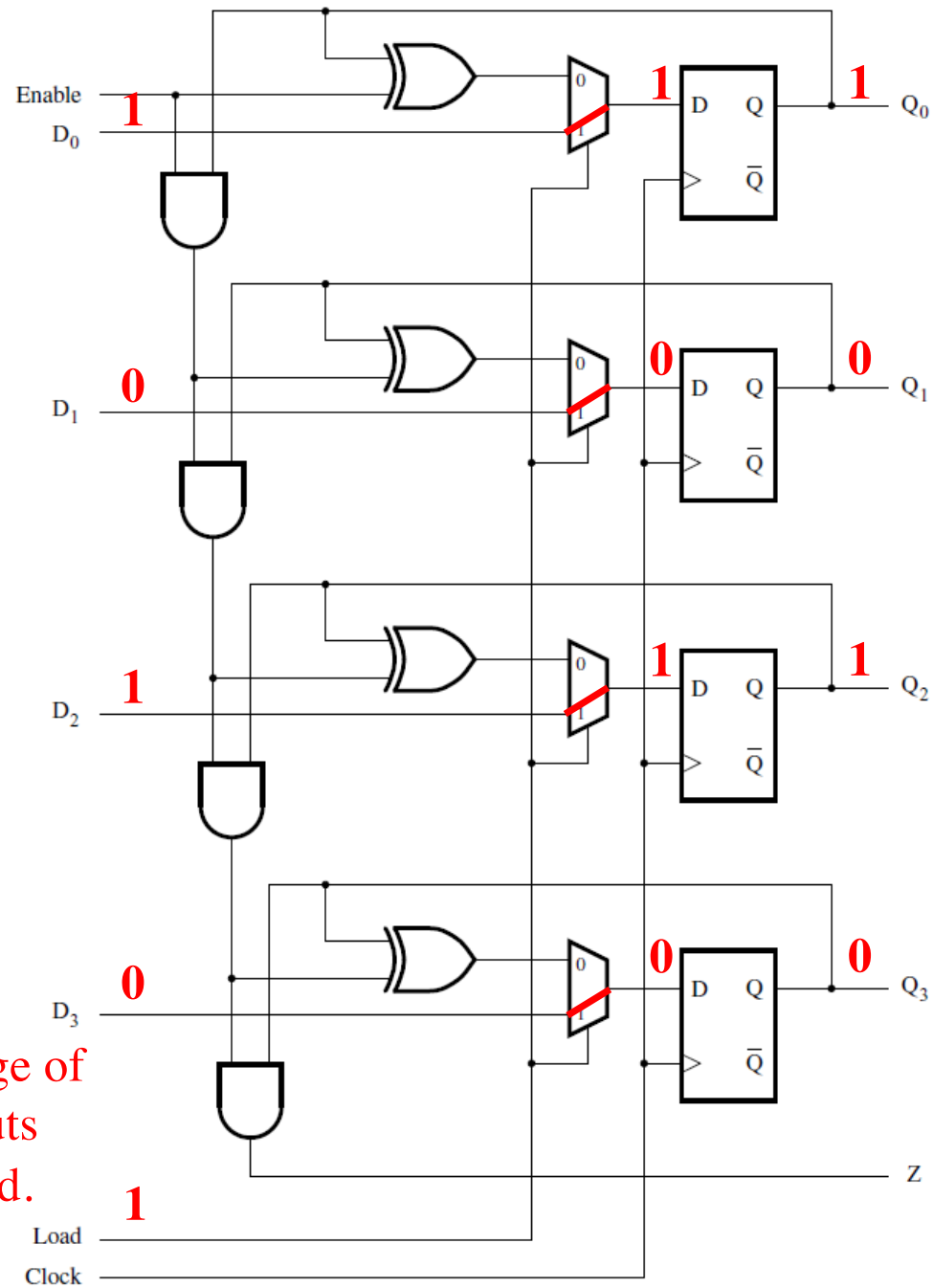

When the next positive edge of the clock arrives, the outputs of the flip-flops are updated.

Reset Synchronization

Motivation

- An n-bit counter counts from 0, 1, ..., 2^n-1
- For example a 3-bit counter counts up as follow
 - 0, 1, 2, 3, 4, 5, 6, 7, 0, 1, 2, ...
- What if we want it to count like this
 - 0, 1, 2, 3, 4, 5, 0, 1, 2, 3, 4, 5, 0, 1, ...
- In other words, what is the cycle is not a power of 2?

What does this circuit do?

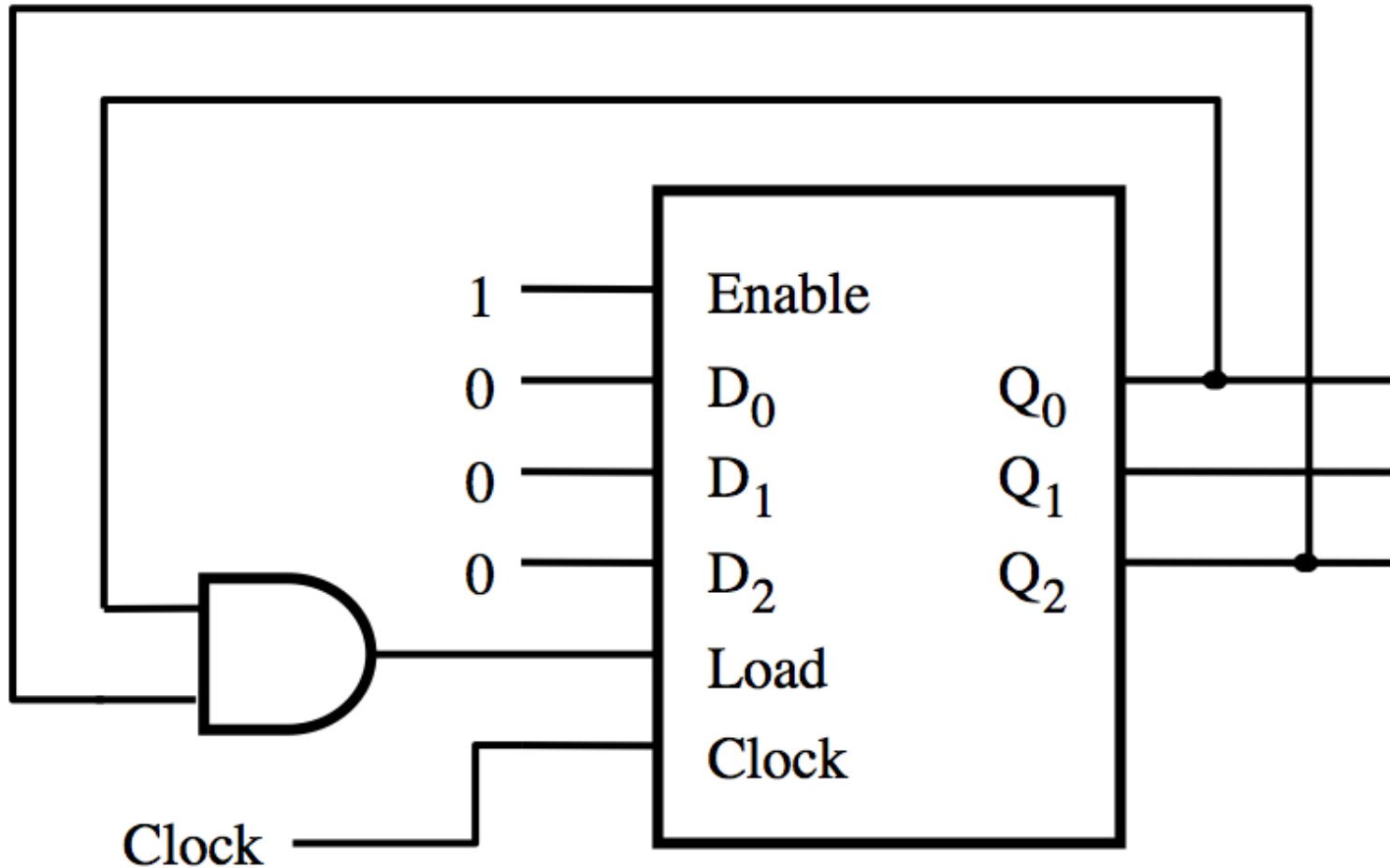

A modulo-6 counter with synchronous reset

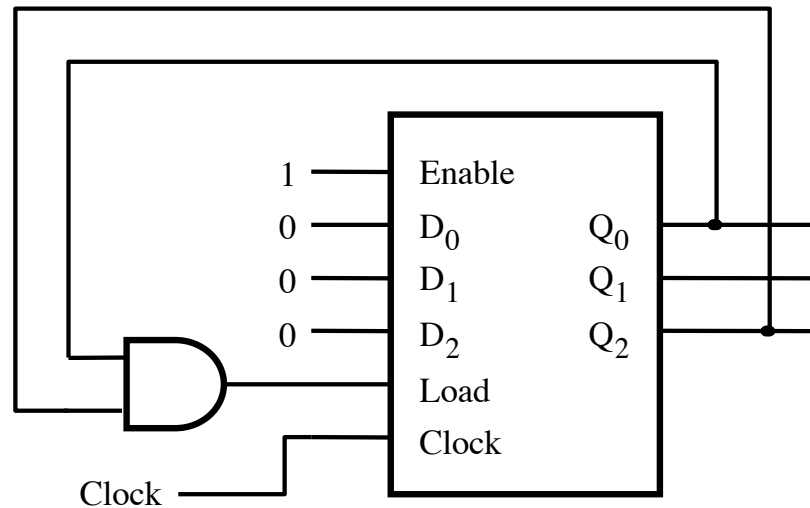

(a) Circuit

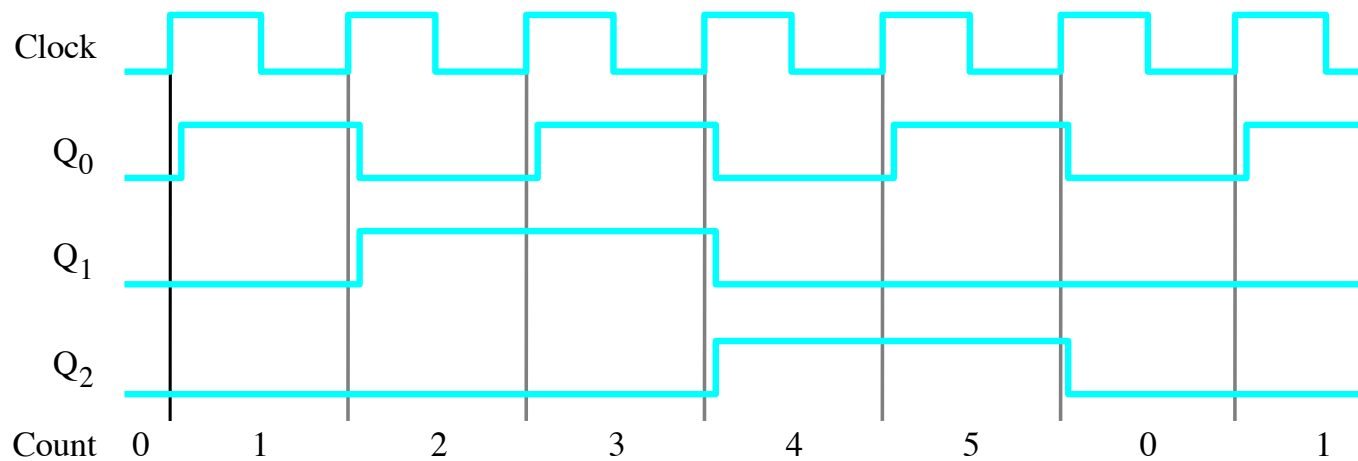

(b) Timing diagram

A modulo-6 counter with asynchronous reset

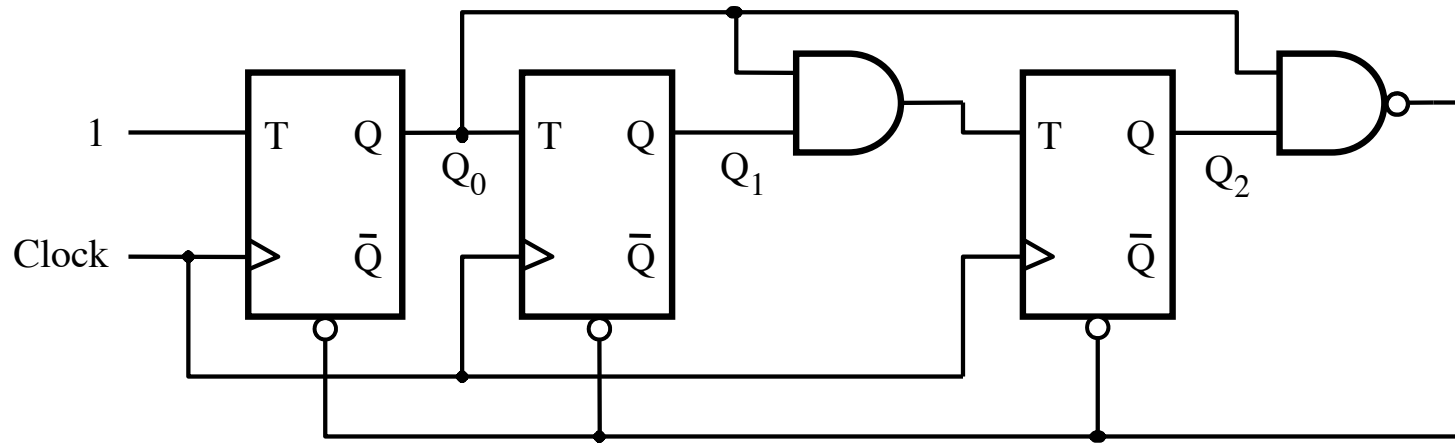

(a) Circuit

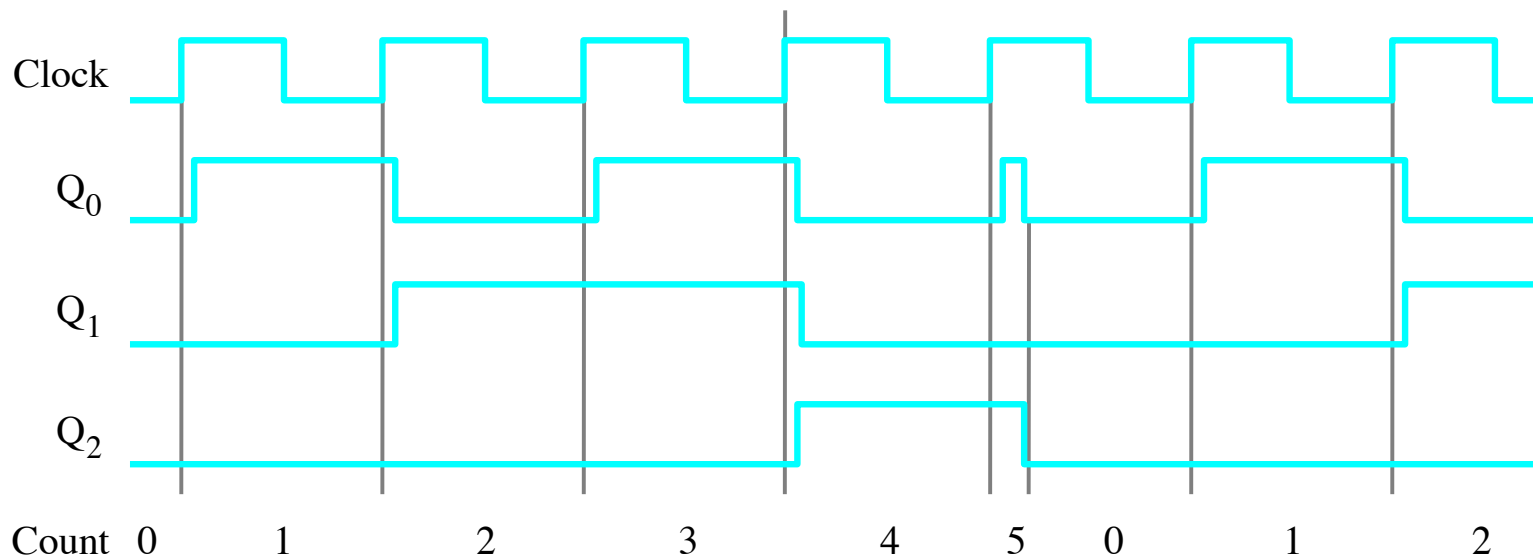

(b) Timing diagram

A modulo-6 counter with asynchronous reset

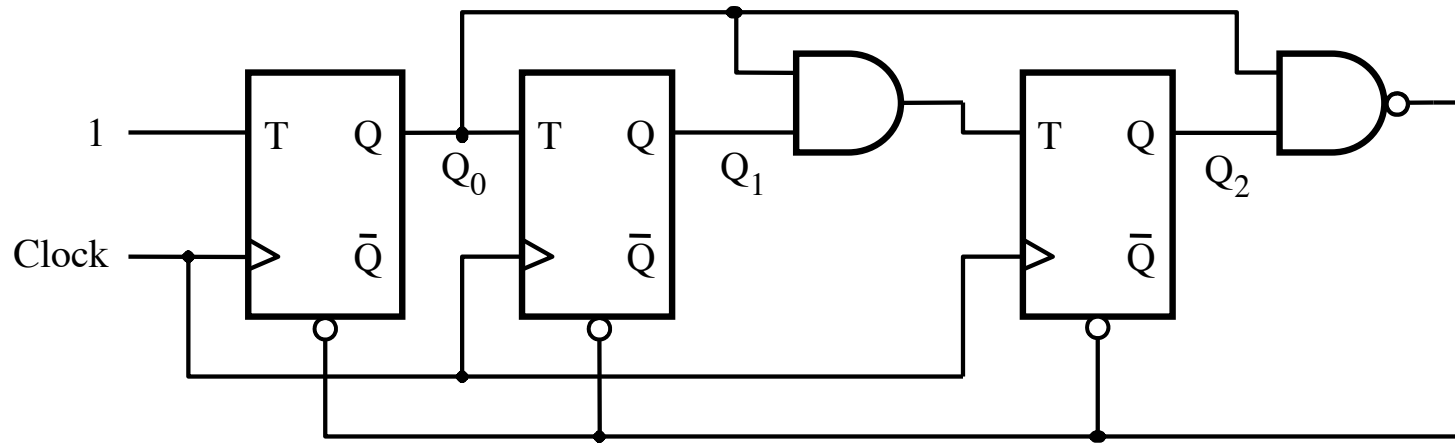

(a) Circuit

The number 5 is displayed for a very short amount of time

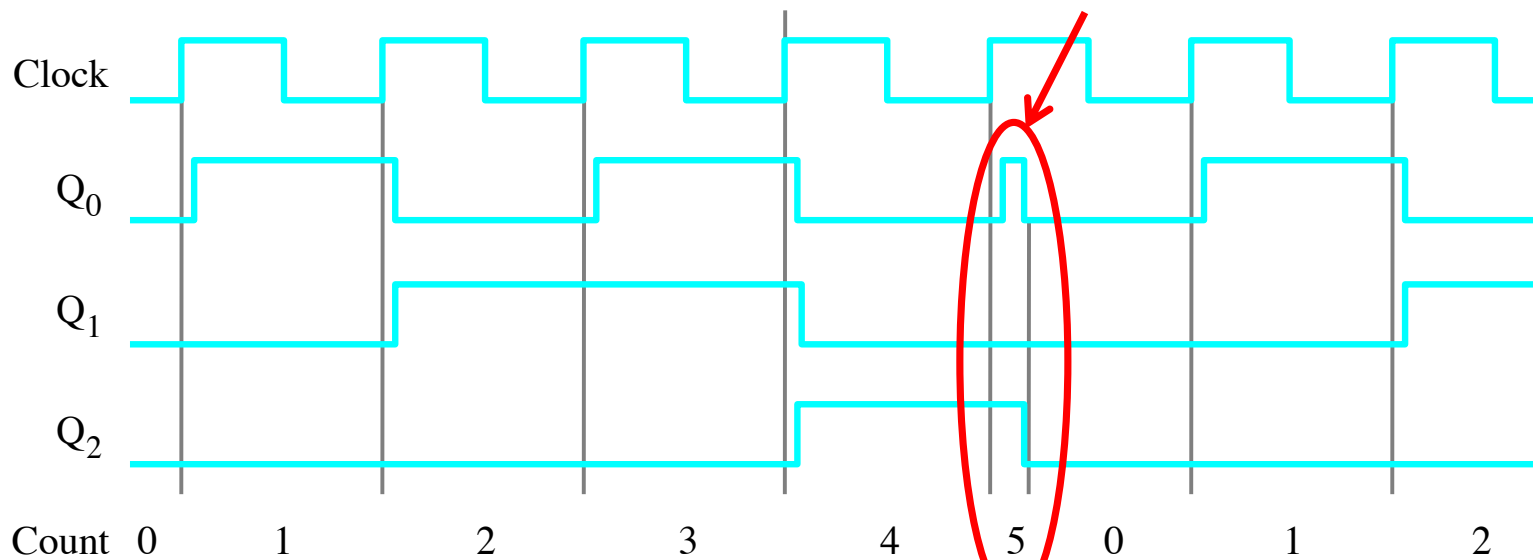

(b) Timing diagram

Questions?

THE END