

Perceiving the Unseen for Enhanced Tool Use

Body Schema Extension via a Vibrotactile Feedback Sensing System

HCI 585X Project Proposal

March 9, 2011

Prepared by: Corey Gwin

Prepared for: Alexander Stoytchev

Table of Contents

| | |
|---|----|
| Project Proposal | 1 |
| Background | 1 |
| Problem..... | 2 |
| Solution..... | 4 |
| Target Users..... | 5 |
| Previous Work..... | 5 |
| Current Systems in the Consumer Market | 6 |
| System Design | 6 |
| Preconditions..... | 7 |
| Hardware..... | 7 |
| Software..... | 9 |
| Test and Evaluation | 10 |
| Test 1: Simple Object Detection and Localization..... | 11 |
| Test 2: Object Perception in the Action of Reversing..... | 12 |
| Test 3: Complex Tool Use Perception (Parallel Parking)..... | 13 |
| Test 4: Bind Spot Object Perception | 14 |
| Qualifications..... | 15 |
| Conclusion | 15 |
| Schedule | A |
| References | B |

Project Proposal

Background

Our brain's ability to perceive is limited by the body's ability to sense information from its physical interactions with the world. We can only move what our muscles move, see what our eyes see, hear what our ears hear, or touch what our skin touches. Nevertheless, thanks to the plasticity of the human brain and continual technologic advancements, we have come to employ a plethora of tools that enhance our physical capabilities and augment our limited sensory abilities. Ranging from simple objects, like hammers that increase our strength, to extremely complex and advanced machines, like the massive United States Air Force C-17 cargo jet that can enhance our navigation, speed, maneuverability, or power. There are, however, limitations to our tool use and these limitations limit our performance, abilities, and level of perception with them.

Often instead, we utilize robots to perform tasks where the human cannot achieve the same level of precision, consistency, speed or strength. Robots, though, also have their own limitations. Unlike humans, robots lack an innate intrinsic motivation to understand their environment and adapt to the frequently occurring changes in it. A new field of robotics, developmental robotics, is attempting to design intelligent machines that learn and develop with a "brain" that understands the world just as humans develop their brain from childhood to adulthood. As a result, the nature, capability, and limitations of the brain have become the focus of roboticists hoping to design machines that will help further evolve human capability. By studying the limitations of the brain, roboticists can design intelligent machines that complement the human incapability. It will be important to understand the malleability of the human brain. From the brain, we can understand where perception of self begins and ends. Through this understanding, we can begin to remove our perceptual limitations and better employ tools in our world.

In the last few decades, neurophysiological, psychological and neuropsychological research has shown the amazing plasticity of the brain to incorporate objects into one's body schema¹ through sensorimotor experiences (i.e. tool use). Maravita et al. (2004) showed, by monitoring the somatosensory and visual receptive fields (sRF & vRF) in Japanese macaques' brains, that after extended tool use, changes in the sRF and vRF indicated "inclusion of tools in the 'Body Schema' as if the effector (e.g. the hand) were elongated to the tip of the tool" [1]. In other words, the tool was not simply an object, it was a controllable feedback providing extension of the brain's body.

In his book Phantoms in the Brain, Ramachandran (1999) shows how our own body "is a phantom, one that your brain has temporarily constructed purely for convenience." Through several demonstrations, he illustrates how "the mechanisms of perception are mainly involved in extracting statistical correlations from the world to create a model that is temporarily useful." In a simple experiment where a subject observes taps on the fake prop hand while simultaneously

¹ One's body schema is a "multicomponential, action-oriented construction" of self-perception "that besides proprioception, other sensory modalities (typically somatosensory and vision) are crucial to its construction" [1].

being tapped on their own occluded from view hand, the subject concludes, in a matter of seconds, that the fake hand is of their own body [2]. We realize from this experiment that our perception of self is not just the physical body we often feel we are constrained to, but rather a malleable and extendable representation formed by correlations of the types feedback we receive from the world.

David Clark illustrates numerous examples of modern day technologies taking advantage of the brains ability to learn new types and channels of input: Australian cyber-artist Stelarc can voluntarily control a mechanical third hand and doctors have enabled quadriplegic patients to move computer cursors through their brain activity [3]. Clark finds that due the capacity of the human brain to learn new modes of controlling action, we experience a fluid, transparent mesh between our will and motion. This fluid experience is what allows the experienced car driver, athlete, and video gamer to operate without ever contemplating the necessary actions required for using the throttle, swinging the baseball bat, or navigating the virtual world with an Xbox controller. He concludes that what we consider as “self” is really a matter of what we can continually and reliably control for our desired outcomes.

Problem

Simple tools are easy to perceive: when I hit the nail with the hammer I feel the strike, I hear the collision, and I see the nail go into the wood. However, with complex and advanced machines, our perception is still limited to the confines of our bodies while often much of the physical interaction with the world is occurring elsewhere. We are only able to perceive as far as the tool provides sensory information to us. For example, a military helicopter pilot may be able to feel the G-forces of a maneuver and the feedback from the joystick, hear the increases in the engine’s RPM and



Figure 1. The many visual cues required to fly a UH-60 Black Hawk helicopter. Source: defenseindustrydaily.com.

audible warning alerts, or see their orientation from the horizon and the optical flow outside the cockpit, but without periodically checking the many gauges around them and listening and communicating with air traffic control and other operators, the pilot may become quickly overwhelmed and unable to operate the helicopter [4] (Figure 1). The leading cause of recent military helicopter mishaps has been due to brownouts². The loss of spatial awareness and reliance on gauges in this rapid and crucial phase of flight causes many pilots to lose control of the air vehicle and crash. Because the pilot lacks the ability to see where they are, they have no easy way of knowing where to go.

² A brownout is a dense cloud of swirling sand and dust that blinds helicopter pilots as they attempt to land.

Of course we have developed robots that eliminate these perceptual complications for us. The United States Navy's MQ-8B Fire Scout Vertical Takeoff Unmanned Aerial Vehicle (VTUAV) is an autonomous helicopter that can takeoff, land, and fly entire missions on its own. While this "unmanned" system and others like it have their advantages over humans, they are still prone to their own perceptual limitations as allowed, designed or, many times, unforeseen by their designers. For example, Fire Scout does not have the ability to sense, avoid, or track objects and targets on its own. While machines may be able to perform and detect in greater capacity than humans, their ability to know what to do with what information they can detect is limited. For now, it seems only animals have the ability to intelligently use information they perceive to influence and understand their world (i.e. learn). By continuing to study how humans perceive, perhaps we can design more intelligent machines that learn do the same.

Close examination reveals that perception requires action. Visual perception specifically is the "activity of exploring the environment in ways mediated by mastery knowledge of the relevant sensorimotor contingencies" [5]. In other words, we only see that with which we physically turn our attention to and, importantly, understand. We cannot simply glance at a panoramic photograph of a cityscape, for example, and then instantly report all the details of the scene. To do so would require us to actively explore the scene in order to gain the information we can understand from it. Visual perception requires that we physically align our bodies to move our heads and then focus our eyes on a particular region of interest. Herein lies a significant problem for human tool use: [with the growing complexity and size of tools, the perceptual reliance on vision to keep tabs on the world outside our tools limits our capability with them.](#)

As humans, we have come up with creative ways of extending our perceptual awareness to the world outside of our tools primarily by use of various visual and audible cues. We use mirrors, gauges, blinking lights, or high pitched tones, but even still, these types of visual and audible cues are not sufficient. Due to automobile blind spots, 50 children are backed over by vehicles each week. Between 2004 and 2008, motor vehicle blind spots caused 41.6% of all children auto deaths. A majority of these accidents occur while the car is coming out of a driveway or parking space [6]. The major factor in these accidents is the driver's inability to perceive what is occurring outside of their vehicle because their vision is occluded (even when the vehicles have mirrors). To respond to this problem, automakers have begun to install wide-angled cameras in automobile rear ends that provide drivers a view of the occluded area behind the vehicle as it reverses. While certainly better than mirrors, these camera systems still require the driver take notice of dangers. It also requires that they utilize the side mirrors in tandem since the camera can only show exactly where it is looking. In addition, the cameras do not alert the driver if an out of view object is approaching. To alleviate the object detection problem, automakers also include audible alerts that alert the driver as the vehicle approaches objects out of the driver's view. Some systems alter the pitch or frequency of the tone accordingly as the proximity to the object changes [7]. While the audible cue is capable of alerting the driver and providing useful information, it is still incapable of providing the exact location or identification of the object. Such a system would require a 3D audio system that would at least allow the driver to perceive the location of the object.

This vision problem can especially become magnified at high speeds when the driver does not have time to keep tabs on the location of objects outside of their visual and perceptive field. Formula 1 drivers, for example, must maintain awareness of other vehicles around them while vigorously navigating and frequently communicating with team members. The race driver does not have time to constantly check their mirrors or cameras or listen for audible alerts since the navigation of the course is taxing their attention. The driver cannot afford to hesitate at the risk of a slower lap time but if they can't detect danger in their blind spot, they may be risking their own and other's safety. Perhaps an easy way the driver could perceive other vehicle locations would be if he could simply *feel* their presence around him.

Solution

The following proposal describes vibrotactile feedback sensing system (VFSS) that attempts to extend the nervous system of the operating user to the surrounding outer surfaces of the tool they are actively using for enhanced perception and performance. For the purposes of this project, that tool will be an automobile. Recall from earlier that if a system can sense what the user cannot sense and is a result of the agent's actions and control, then that system can enhance the agent's perception and become an extension of the agent's body schema. The VFSS will not attempt to replace vision; it will only enhance their overall perception of the world around their tool. The VFSS will allow for further study of human attention and perception. It will also evaluate the utility of the human nervous system as an alternative means to perceive the world in advanced tool use. Due to the availability and cost of hardware, the VFSS proposed in this project will initially consist of a single sensing sensor that detects the three dimensional nature of occluded objects and then relays that objects information with a vibrotactile array.

While visual stimuli require an agent to actively explore a specific region of interest to perceive it, a tactile stimulus only requires that the user feel it, acknowledge the location of its presence and then interpret its meaning. For example, we do not have to continually see the chair or ground under us; we just feel that it is there. With vision, we must make a greater physical effort to perceive. The tactile stimulus is also different from an audible stimulus since it is possible to detect the shape, form, and even identity of objects by touch alone and very difficult to do so by sound alone. Perhaps you have played the game of trying to identify objects in a bag by touching them while blindfolded – this task would be nearly impossible to do by simply listening to them (especially if they are inanimate and soundless).

Several simple uses for such a haptic system can come to mind: truck drivers who physically feel the presence of vehicles entering their occluded blind spots, helicopter pilots who feel the ground approach beneath them as they land in swirling clouds of dust, or security agents who can feel the presence of intruders while focusing their visual attention with a camera elsewhere.

Of course the haptic feedback is only as good as the system's sensors' abilities are to detect and provide feedback to the tactile array. Newer vision technologies, such as radars and infrared time of flight cameras, can collect accurate high resolution data that pervious cameras could not and are more human like in their operating nature. Using the expansive human nervous system as an input surface for feedback can provide a new opportunity for enhanced perception in tool use.

Using haptic feedback to extend the nervous system to the surfaces and capabilities of tools allows the agent to not only see, but to simultaneously “feel” the world in new ways.

Target Users

The system proposed in this project will focus primarily on enhancing an automobile driver’s ability to perceive visually occluded objects during activities such as reversing, parking and lane changing. The VFSS would be appropriate for all automobile drivers but especially for drivers with vehicles that have large visual occlusion (e.g. SUV, semi-trucks, etc.). The VFSS will also be ideal for operators whose visual and audible attentive awareness are already heavily utilized in their tool use. Race car drivers, aviators, and astronauts are all examples.

Previous Work

Most haptic feedback systems up to today have primarily been designed for telerobotics, virtual reality immersion or vision replacement systems for the blind [8]. Bach-y-Rita successfully created a high resolution tactile vision *substitution* system (TVSS) by providing electro-tactile stimulation to a user’s tongue. This system was focused primarily as being a replacement of vision for the blind [9]. They found that skilled users of the TVSS were able to track, identify objects and respond accordingly as they manipulated objects in the world. Skilled users with the TVSS also reported the sensation of altogether not even noticing the tactile nature of the sensor, simply just saw at.

Inspired by Bach-y-Rita’s pioneering work, Bird et al. created similar sensors on a much smaller scale. They call their TVSS a minimal TVSS. Their research found that a simple 5 by 4 array of vibrotactile sensors were ideal for proficient perception and object tracking, but even a 2 by 3 array was sufficient for a simple ball tracking tasks. The minimal TVSS was worn as a belt, bracelet, and vest and could be felt through clothing by simply attaching them Velcro [10]. Recently, Bird et al. have begun exploring the uses of vibrotactile systems as guides for human behavior. In a similar manner to what i wish to achieve, the minimal TVSS can provide guidance for learning in activities such as learning to play a violin or the drums (Figure 2) [11].

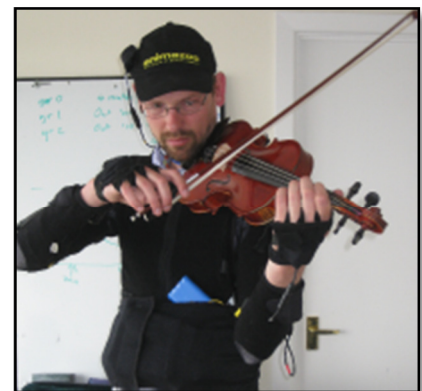

Figure 2. Vibrotactile feedback used to train novice violin players. Photo by Jon Bird.

In other work, at the University of Minnesota’s Center for Transportation Studies, the HumanFIRST program is employing the tools and methods of psychology and human factors engineering to improve driver performance and cognitive functions. In one relevant study, the HumanFIRST researchers studied a variable resistance feedback accelerator pedal that varied with how closely the driver’s vehicle followed a lead vehicle. Interestingly, they found that drivers responded much more quickly to a sudden slowdown by lead vehicle with the haptic feedback, but took longer to transition to the brake, suggesting that the driver performs a visual double-take to insure the lead vehicle is actually slowing down since they are not used to the system. The overall reaction time, however, was significantly better with haptic feedback than without it. In a follow-on study with the same system, drivers followed a lead vehicle as a primary task but also manipulated a touch screen display as a secondary task as many times

as they could within a two minute period. This secondary task was considered a relatively more perceptually demanding task than simply adjusting the stereo. Researchers found that the haptic feedback improved driver’s ability to perform both of the primary and secondary tasks, suggesting that drivers took advantage of the “newly freed resources” from the haptic system [12].

Current Systems in the Consumer Market

As mentioned, all tools provide the user some form of feedback, but for a majority of the advanced systems on the consumer market, visual perception appears to be primary designed feedback source. Current haptic feedback is weak or nonexistent for many advanced consumer market systems. This may primarily be because it is hard to implement a system that can reliably touch the user. Perhaps cell phones are the only wide users of haptic feedback. We’ve become very familiar with cell phones using vibration to discretely alert their users. Newer smartphones and video game controllers are using haptic feedback in much more realistic ways to enhance the perception of their virtual games and applications (e.g. feeling the virtual guitar vibrate when strummed or table shake when the pinball hits a bumper [13]).

For vehicle sensing, the car company Infiniti is perhaps the leading industry innovator for smart car sensing technologies but all but one of their systems do not utilize haptic feedback (and it is a rather indirect braking that provides the feedback). By utilizing various radars, ultrasonic detectors, wide angled cameras, blinking lights, and audible tones, Infiniti offers their customers a wide array of smart sensing systems for their vehicles. These systems include an intelligent brake assist that helps warn against potential collisions by automatically applying the brakes, a blind spot intervention system that monitors and detects other vehicles in the driver’s blind spot area with blinking lights and tones, and a parking aid gives the driver the ability to see a virtual 360° view of the parking environment [14]. All very helpful perception systems, but none of them providing haptic feedback for the freeing of perception resources.

System Design

An implementation schedule can be found in the appendix. The VFSS will consist of a 3D vision sensor, a vibrotactile array, and a laptop computer for image processing and vibrotactile array control. An Arduino ATmega328 microcontroller will receive commands from the laptop computer via USB. The Arduino will use the Texas Instruments 16-Channel LED integrated circuit to control the pulse width modulated (PWM) signals to vibration motors in an array (i.e. the Arduino will vary the intensity of the vibration by the motors). For this first VFSS, the vibration motors will be arranged in a 3 by 3 array and be attached to the driver’s back or seat with Velcro. The array will be tested at several other locations including the hand and neck to see if the location sensitivity aids in the driver’s perception.

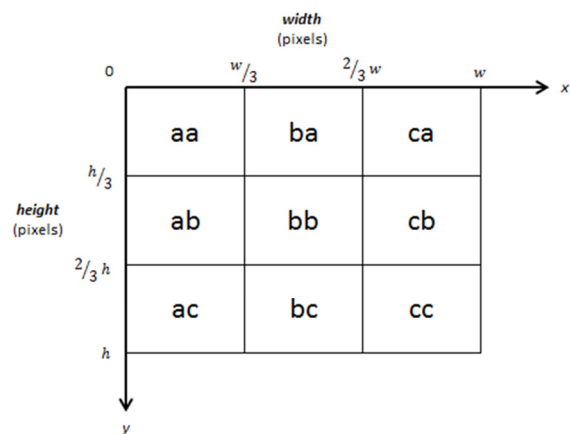

Figure 3. The VFSS 3 by 3 depth and vibrotactile grid coordinate system. The PrimeSensor depth image has a resolution of 640 by 480 (width and height).

The 3D vision system employed for this project will be the Microsoft Kinect with the PrimeSense PrimeSensor technology. The Kinect will be affixed at various angles at the rear of the automobile for sensing objects in the driver’s blind spot. The laptop will process the imagery by determining the depth of objects behind the automobile and trigger specific vibrotactile intensities to clue the driver in on the location of the objects. A 3 by 3 grid of the field of view will correlate to the 3 by 3 grid of the vibrotactile array. Each box in the grid will measure the average depth value of all the pixels in each box and then use that average value to relay the appropriate vibrotactile intensity to the driver. Figure 3 shows the 3 by 3 depth and vibrotactile grid. Note that the Kinect provides a 640 by 480 pixel capture, width and height respectively. With time and budget permitting, additional vibration motors and vision boxes will be added to the VFSS array for higher resolution depth detection³; however, gleaned from Bird et al.’s research, I suspect that satisfactory object perception will be capable from this simple 3 by 3 array.

Preconditions

In building my own prototype I require that the system will only be used in controlled environments. These environmental details include ensuring there is little or no sunlight during testing to minimize the amount infrared (IR) interference on the PrimeSensor outdoors, no adverse weather, and properly functioning hardware. These conditions ensure the reliability of the hardware, safety of the testers and produce consistent data and reliable results.

Hardware

Figure 4 shows an initial breadboard schematic of the vibrotactile array electronics that will be constructed and evaluated in this project. The following hardware and their quantities will be required for the VFSS:

- Microsoft Kinect with PrimeSense PrimeSensor x 1
- Arduino Duemilanove microcontroller board (ATmega328) x 1
- Texas Instruments 16-Channel LED Driver (TLC5940NT) x 1
- LilyPad Vibe Board x 8
- Laptop computer (Intel i3 with 4 GB memory and an ATI HD5740 with 512 MB onboard)
- 2000 Ford Focus ZX3 x 1

Table 1. Microsoft Kinect Technical Specifications [15].

| Horizontal Field of View (HFOV) (°) | Vertical Field of View (VFOV) (°) | Dead Zone of Depth Detection (m) | Field of View Range of Depth Detection (m) | Data Stream Resolution (-) |
|-------------------------------------|-----------------------------------|----------------------------------|--|--|
| 57 | 43 | 0 - 1.2 | 1.2 – 3.5 | 640x480 32-bit color @ 30 frames/sec |

³ If the human eye were a digital camera, its full angle of vision captures spatial detail with a resolution of 576 megapixels (this is just with just one eye) [18]. Compare this resolution to the PrimeSensor’s measly 640 by 480 depth image at only 0.3 megapixels. Even if we could scrounge up 576,000,000 vibration motors, I’m not sure we would have enough real estate one’s body to relay the amount of detail through touch that the eye can effortlessly detect. Even though we do not perceive all of this detail, it is captured by the eye nonetheless and there for us to detect (with brightness, depth, and color and all). One may begin to wonder what the sensing “resolution” of the one’s own skin is.

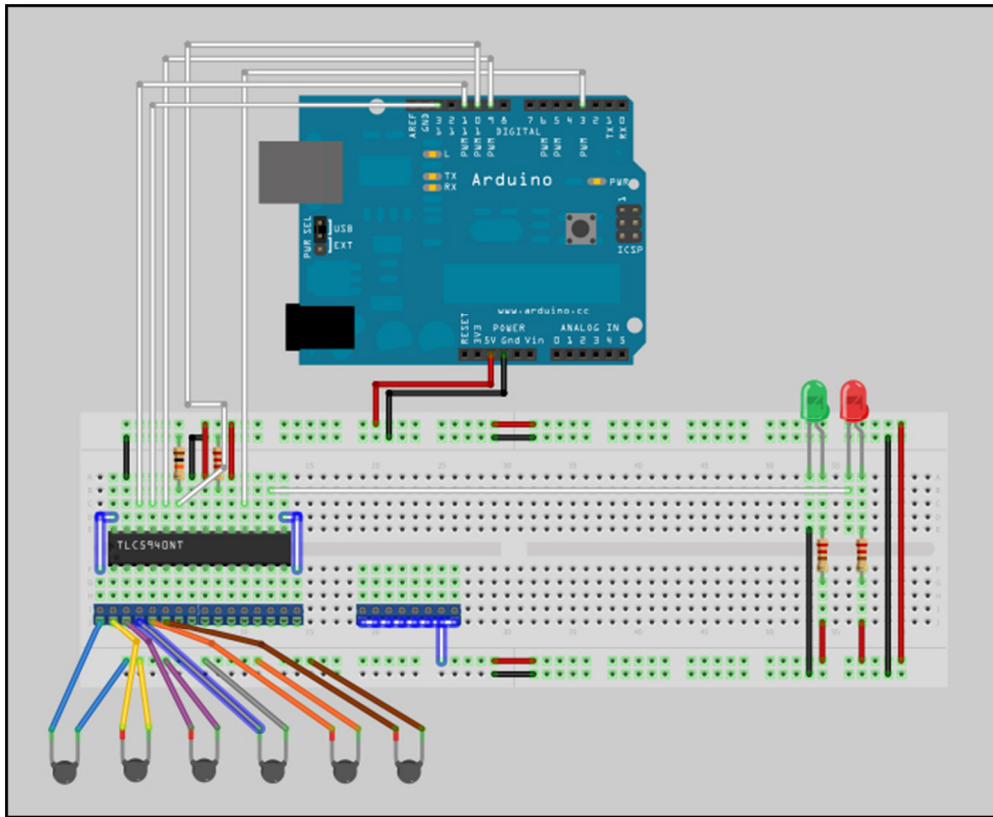

Figure 4. Breadboard schematic of the vibrotactile feedback sensing system (VFSS).

The Microsoft Kinect technical specifications can be found in Table 1. The Kinect optical subsystem, the PrimeSense PrimeSensor, consists of three components: a depth projector (high powered IR LED), a depth sensor (CMOS IR image sensor), and an RGB sensor (CMOS color image sensor). By scattering a specific pattern of coded, near-infrared, structured light into the environment, the PrimeSensor is capable of capturing a depth image based on the returns of the IR light within its field of view. It then creates a topographical view of the scene by correlating the depth pixels with each pixel of the simultaneous color image. Due to the PrimeSensor's use of IR light, VFSS will only be able to operate inside, in the shade, or during the evening when ambient IR light from the sun will not interfere. The Kinect also has a motor subsystem capable of a few degrees of vertical tilt and an audio subsystem pinpoint noise canceling audio capture, but these features will be disabled for the VFSS.

Figure 5 shows a sketch of the Microsoft Kinect mounted on my 2000 Ford Focus ZX3. The green circle indicates the start of the PrimeSensor's depth detection; everything prior to this area is considered a dead zone. The rest circle indicates the furthest depth detected by the sensor. As seen in the figure, the ground behind the vehicle will be in the sensor's field of view. This will require the sensor to be calibrated and zeroed upon installation and initialization. While the range of the PrimeSensor is likely not great enough for high speed driving awareness, it will prove useful in parallel parking, reversing, and low speed lane changes.

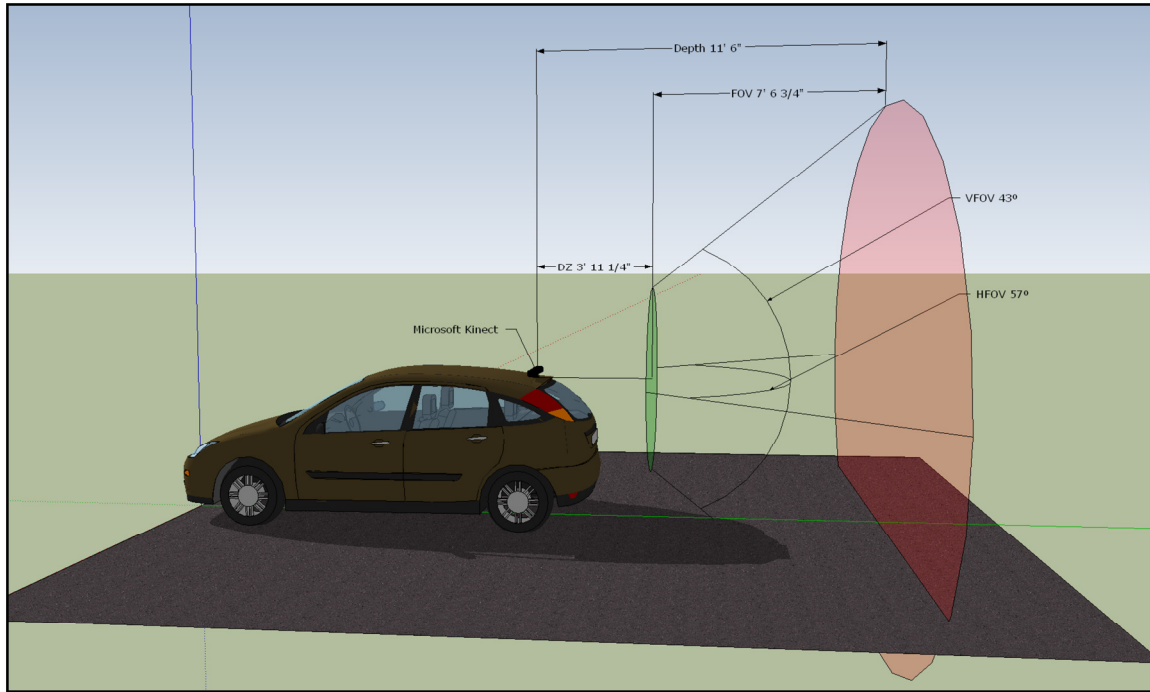

Figure 5. Microsoft Kinect mounted my 2000 Ford Focus ZX3 and the corresponding Field of View (FOV) dimensions.

Software

The VFSS will use the libfreenect drivers and libraries to communicate with the Kinect from the laptop computer running the Linux (Ubuntu 10.10) operating system. The image processing software will be written in Processing⁴ with the OpenKinect⁵ library. Figure 6 shows a depth image point cloud captured from the PrimeSensor with VFSS grid coordinate system overlaid.

Raw sensor values returned by the Kinect's depth sensor are not directly proportional; sensor values scale with the inverse of the depth. Other individuals have done relatively accurate studies to determine the necessary coefficients resulting in high accuracy depth detection. Using the appropriate formula [16], I will be able to map these raw PrimeSensor depth values (i, j, v) into world coordinates (x, y, z), where i and j are the horizontal and vertical locations of the depth value, respectively, and v is the raw depth value. The depth value, v , varies between 0 and 2047. After receiving the raw depth point cloud values in the VFSS grid, Processing will calculate the average depth of objects within each box of the Kinect's field of view.

⁴ Processing is an open source java based programming language and environment for people who want to create images, animations, and interactions. Initially developed to serve as a software sketchbook and to teach fundamentals of computer programming within a visual context, Processing also has evolved into a tool for generating finished professional work. Today, there are tens of thousands of students, artists, designers, researchers, and hobbyists who use Processing for learning, prototyping, and production. <http://processing.org/>

⁵ OpenKinect is an open community of people interested in making use of the amazing Xbox Kinect hardware with PCs and other devices. They are working on free, open source libraries that will enable the Kinect to be used with Windows, Linux, and Mac. http://openkinect.org/wiki/Main_Page

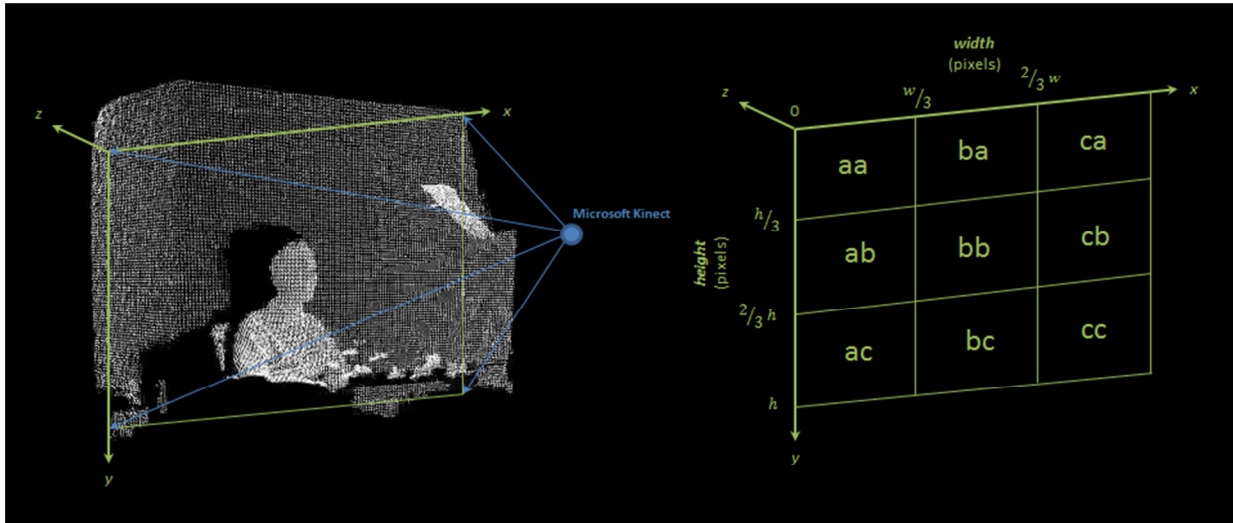

Figure 6. Point cloud capture in Processing from the Microsoft Kinect with Kinect depth and array coordinate systems.

I will also use Processing to control the Arduino with a modified version of the Firmata Arduino firmware. Firmata is a standard firmware that is uploaded to the ATmega328 for communication from the Firmata Processing library. Once the depths of objects within the grid have been determined by the Processing algorithm, the intensity of various vibration motors will be controlled by the Arduino TLC5940NT control code over serial. With each nine motors requiring two bytes per output requires 18 bytes of buffer. I expect to control these motors at around 20-30 Hz, so overall the serial will require only 360 baud. The available TLC5940NT Arduino library will serve as a starting point for generating the new firmware to control six of the TLC5940NT's PWM channels.

Test and Evaluation

The VFSS will be subjected to four different tests to evaluate the utility of the human nervous system as an alternative means to perceive the world in advanced tool use. All four tests will also concurrently evaluate two already implemented visual cues such: mirrors and a rear facing camera. The first test evaluates the VFSS's sensitivity to detection and object localization. The second test, similar to the first, but instead requires the operator perform an action (driving in reverse) to initiate the sensory input. To test both the detection and localization and utility, the driver will be required to reverse through a course, aiming to hit as many objects of various sizes as possible while simultaneously text messaging and attempting to finish in the best possible time. The third test evaluates the VFSS's ability to aid complex tool use perception (parallel parking). The final and fourth test will evaluate the VFSS's ability detect objects in the vehicle's blind spot and low speeds while performing a secondary task.

Brief test descriptions for the four VFSS tests follow:

Test 1: Simple Object Detection and Localization

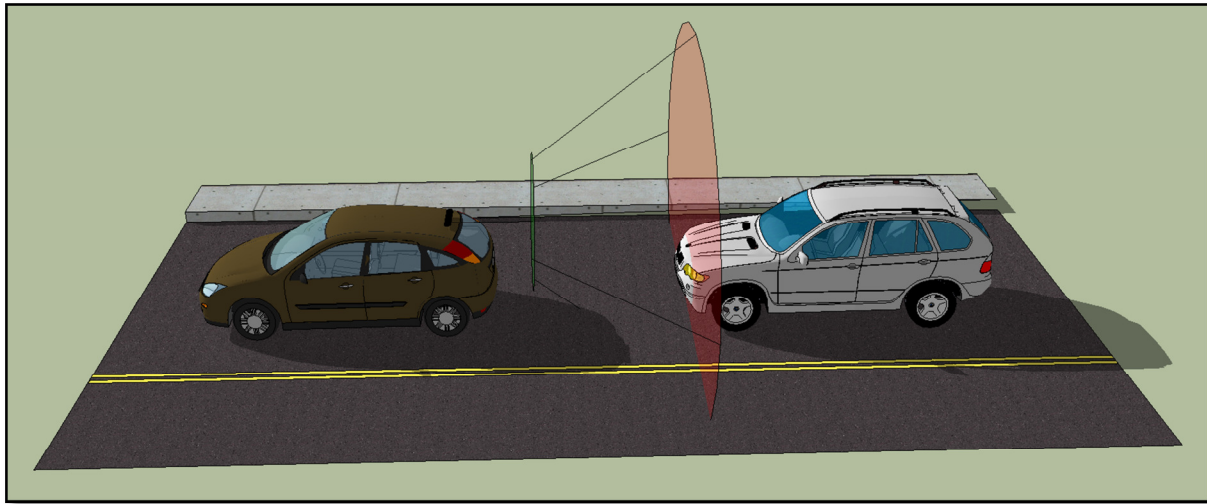

Figure 7. Test 1 object detection and localization example.

Setup: Mount the VFSS sensor facing directly backwards on the rear end of the vehicle.

Test: While the vehicle remains stationary, during a two minute period, the driver should attempt to detect and localize objects in the rear at three different heights (2 ft, 4 ft, and 6 ft) moving at random locations for the following sensory cases three times each:

- Case A: Using mirrors alone
- Case B: Using a rear facing camera alone
- Case C: Using the VFSS alone
- Case D: Using both the VFSS and rear facing camera

Evaluate: Results will be ranked by the driver's ability to successfully detect objects and, separately, successfully continually locate the object while in the field of view. A successful localization does not imply a successful detection as a driver could be guessing.

Test 2: Object Perception in the Action of Reversing

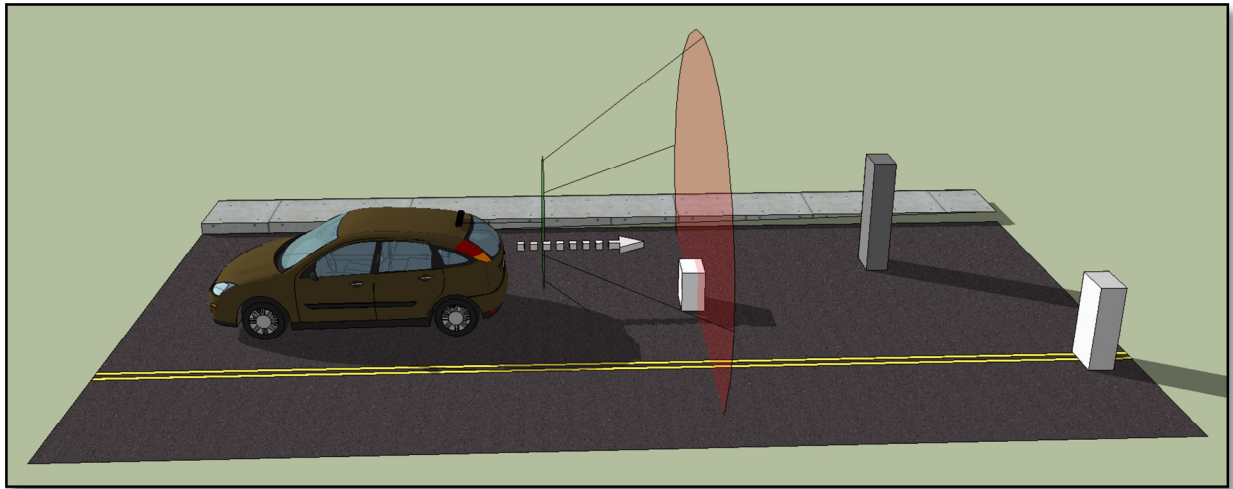

Figure 8. Test 2 object perception through the action of reversing a course.

Setup: Mount the VFSS sensor facing directly backwards on the rear end of the vehicle. Setup a 160 ft course with by randomly place objects of three different heights (2 ft, 4 ft, and 6 ft) about 8 ft apart.

Test: As a secondary task, the driver must send a standard text message as many times as possible while performing the primary task of maneuvering the vehicle in reverse, attempting for the best lap time across a 160 ft course where the driver must simultaneously run over objects for the following sensory cases three times each:

- Case A: Using mirrors alone
- Case B: Using a rear facing camera alone
- Case C: Using the VFSS alone
- Case D: Using both the VFSS and rear facing camera

Evaluate: Results will be ranked by the driver's ability to successfully detect objects and come into contact with the objects while sending the most text messages and having the fastest course. Each missed object will add 5 seconds to the overall lap time.

Test 3: Complex Tool Use Perception (Parallel Parking)

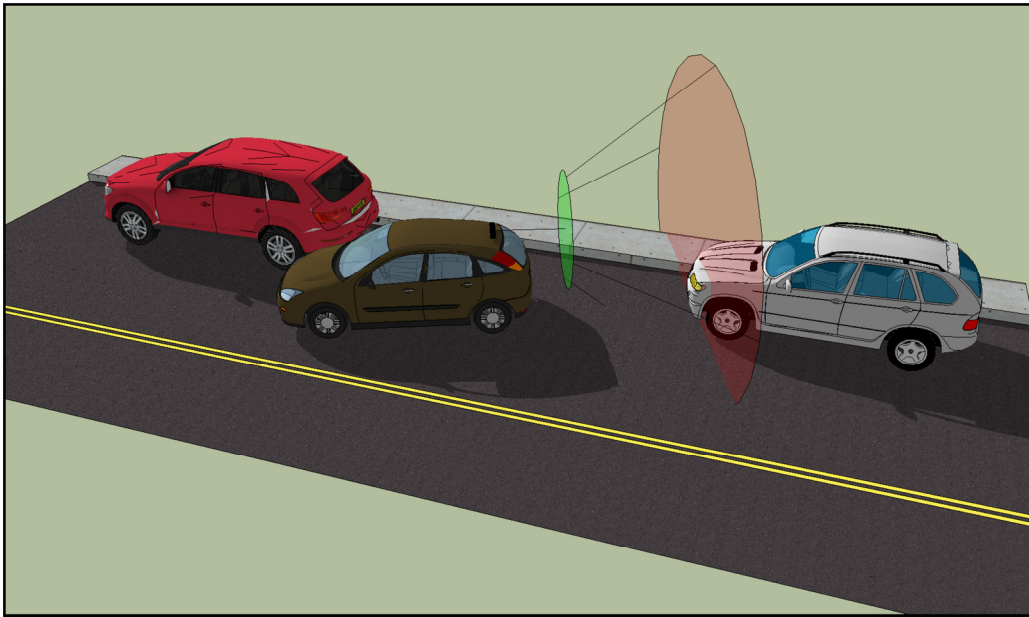

Figure 9. Test 3 complex tool use perception (parallel parking).

Setup: Mount the VFSS sensor facing directly backwards on the rear end of the vehicle. Place two cars far enough apart to allow for the test vehicle to park via a parallel parking maneuver. The driver should be unfamiliar with the vehicles parallel parking characteristics.

Test: Starting from along the side of the front vehicle, attempt to park the driver should attempt to park their vehicle using a parallel parking maneuver as quickly as possible for the following sensory cases three times each:

- Case A: Using mirrors alone
- Case B: Using a rear facing camera alone
- Case C: Using the VFSS alone
- Case D: Using both the VFSS and rear facing camera

Evaluate: Results will be ranked by the driver's the time required to park. Striking another vehicle or the curb disqualifies that test point.

Test 4: Bind Spot Object Perception

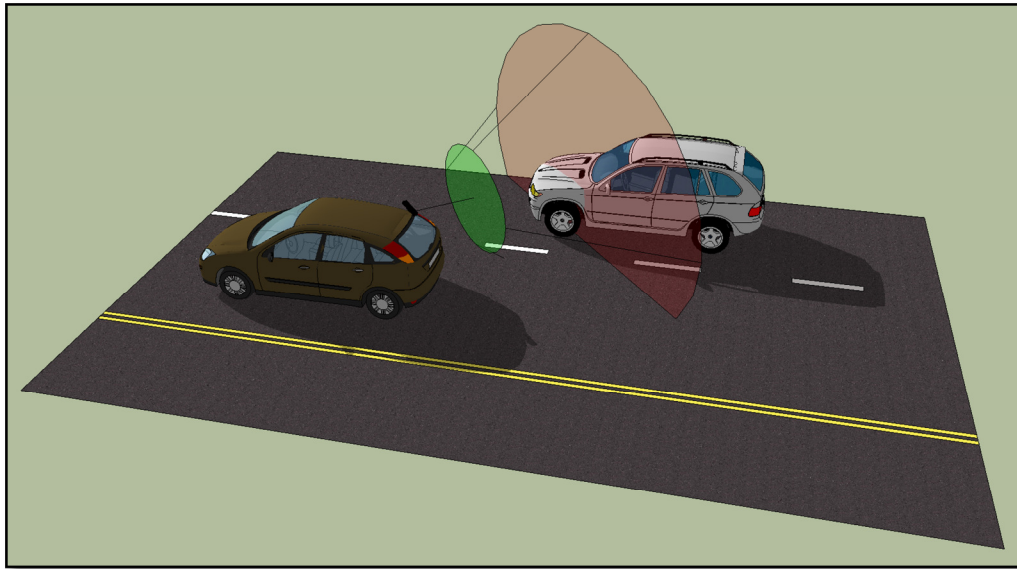

Figure 10. Test 4 blind spot object perception.

Setup: Perform this test in an empty parking lot with space and at low rates of speed. Mount the VFSS sensor on the vehicle facing backwards and slightly angled towards the passenger side (Figure 10). Place 3 cones roughly 20 ft apart. A second vehicle will tail the vehicle and attempt to pass through the blind spot and random.

Test: At low speed, the driver should attempt weave from one side of the starting cone to the other of the middle, around the end cone, and back again for following cases three times each:

- Case A: Using mirrors alone
- Case B: Using a rear facing camera alone
- Case C: Using the VFSS alone
- Case D: Using both the VFSS and rear facing camera

Evaluate: A test point is considered successful if the driver does not weave around the cone due to detection of another object in its blind spot.

Qualifications

Corey Gwin

I am a first year graduate student in the Human-Computer Interaction program via Engineering Online Learning at Iowa State University. I received my BS in Mechanical Engineering from the California Polytechnic State University, San Luis Obispo in 2009 focusing primarily in mechatronics. Among a myriad of other projects at Cal Poly, I designed, programmed and built an autonomous heliostat that tracked the sun's position across the sky and reflected its energy at specific target for solar-thermal power.

Currently, I am employed by Northrop Grumman Aerospace Systems at the Tactical Unmanned Systems division in San Diego, California. There I work as a payload and weapon systems integration engineer for the MQ-8B Fire Scout program, providing state-of-the-art reconnaissance, surveillance, and target acquisition solutions. Though my degree was in mechanical engineering, all of my professional experience, including work at the Edwards Air Force Base Flight Test Center, has primarily been electrical and software engineering based. In addition to systems design, I've designed several engineering visualization and simulation software tools. One tool visualizes Joint Direct Attack Munition (JDAM) Launch Acceptability Range (LAR) telemetry data for the B-1B test program, another simulates B-52H weapons employment hardware procedures for test engineer training, and another quickly displays and calculates and presents intuitive displays of mass properties data for various weapons configurations on the F-35 Joint Strike Fighter program.

With a strong love for technology and learning, I strive to apply my technical ingenuity and passion for innovation, advancing the capabilities and ensuring the safety of the human race. I hope to integrate new computer and sensor technologies into our human experience that allow us to further interact with the world in better ways that we previously could not. My aim is to move technology away from one's fingertips and instead into one's natural existence where the smarts are not in a device, but instead in us.

Future Work

The VFSS proposed in this project is only an initial prototype. Future works should seek to utilize more sensing sensors and corresponding vibrotactile arrays. The entire area surrounding the tool would provide feedback to clue the operator in on information from locations they do not currently perceive. An example of a future VFSS as installed on a formula 1 race is shown in Figure 11. It is possible that future VFSS could consist of entire suits, much like the G-suits worn by aviators and astronauts. With such a suit, operators could learn to attain significantly more information from the environment in all directions, constantly, and simultaneously.

A significantly more improved vision system than the one currently proposed for this VFSS should be investigated. The PrimeSensor cannot operate in outdoors during day time due to infrared interference and it's depth of detection may not be ideal for tool use situations. Also, research should investigate the ability for the user to manipulate the sensing control from their own movements in the tool or by movements of the tool.

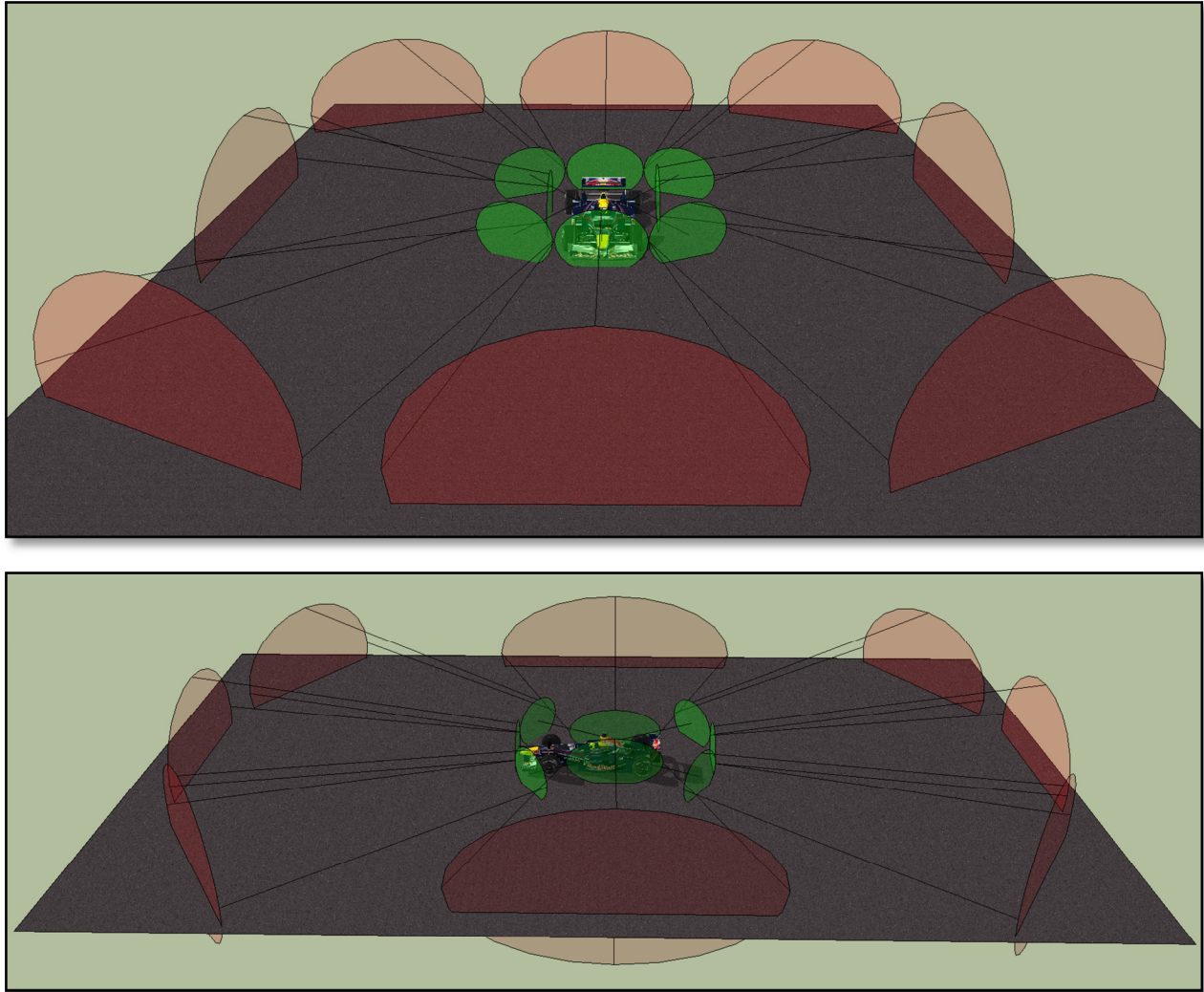

Figure 11. Future multi-sensing VFSS as installed on a formula 1 race car with enhanced sensing system.

Conclusion

The hope of this project is to allow users of the VFSS to extend their nervous system to the outer surfaces of the very tool they are actively using. With this enhanced perception through extension of their body schema, the performance and capability with their tool use will increase. Fabricating the VFSS and creating my own firmware for the Arduino to operate at the operating speed necessary could prove difficult but overall the task seems to be an achievable task with the given timeline.

I also hope that this research will help us continue understand perception. By better understanding how we see the world through touch and the VFSS, we can reveal new and other efficient ways of interacting with our world.

Schedule

As of March 12, 2011

Vibrotactile Feedback Sensing System (edit)

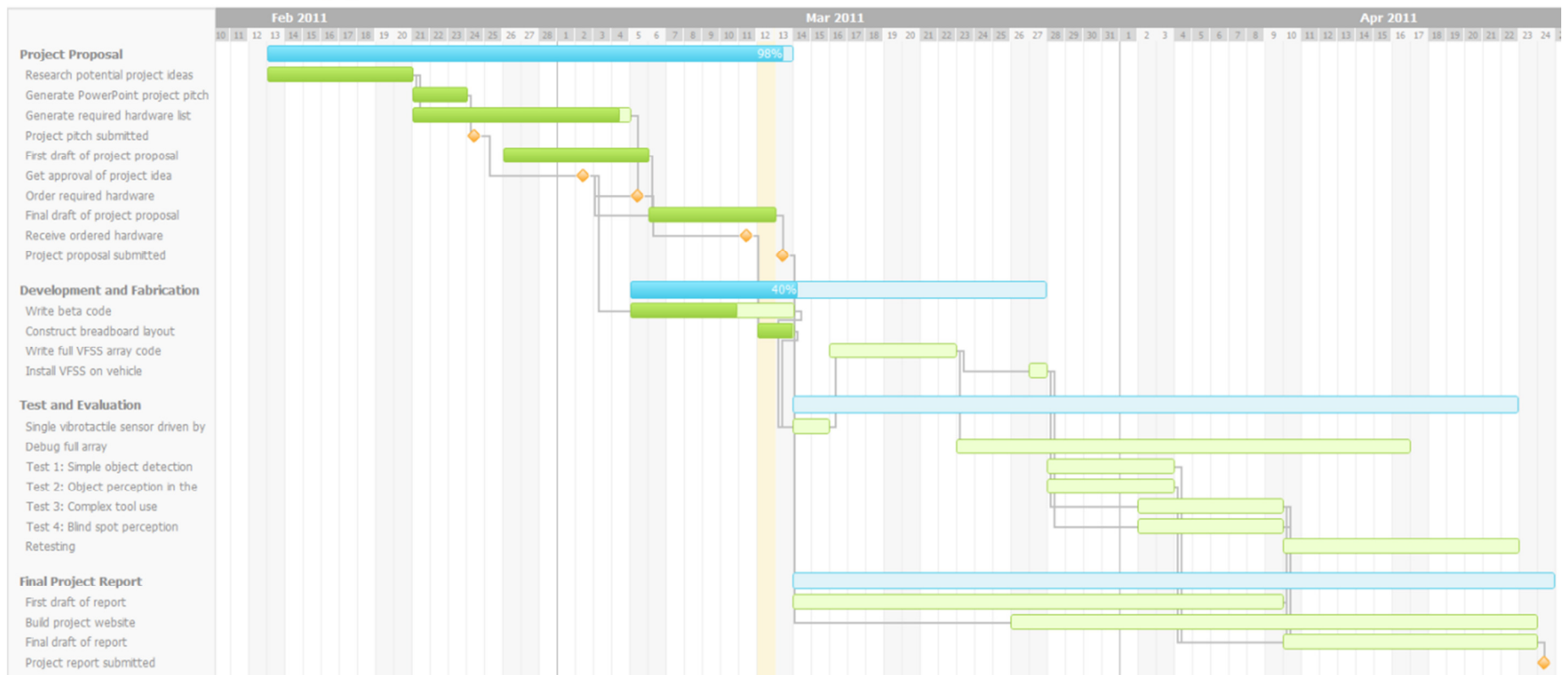

References

- [1] Angelo Maravita and Atsushi Iriki, "Tools for the body (schema)," *TRENDS in Cognitive Sciences*, pp. 79-86, 2004.
- [2] V.S. Ramachandran, *Phantoms in the Brain: Probing the Mysteries of the Human Mind*: Harper Perennial, 1999.
- [3] Andy Clark, *Natural-Born Cyborgs: Minds, Technologies, and the Future of Human Intelligence*: Oxford University Press, 2003.
- [4] Lt. Col. Steve Colby. (2005, March) Aviation Today. [Online]. <http://www.aviationtoday.com/rw/training/specialty/1418.html>
- [5] J. Kevin O'Regan and Alva Noë, "A sensorimotor account of vision and visual consciousness," *Behavioral and Brain Sciences*, pp. 939-1031, 2001.
- [6] Tatiana Morales. (2002, October) CBS News. [Online]. <http://www.cbsnews.com/stories/2002/10/22/earlyshow/living/parenting/main526462.shtml>
- [7] (2006) JDPower.com. [Online]. <http://www.jdpower.com/autos/articles/Reverse-Parking-Assist-Systems/>
- [8] Robert J. Stone, Haptic Feedback: A Potted History, From Telepresence to Virtual Reality.
- [9] Paul Bach-y-Rita and Stephen W. Kercel, "Sensory substitution and the human-machine interface," *TRENDS in Cognitive Sciences*, pp. 541-546, 2003.
- [10] Jon Bird, Paul Marshall, and Yvonne Rogers, Low-Fi Skin Vision: A Case Study in Rapid Prototyping a, 2009.
- [11] Jon Bird, Janet van der Linden, and Erwin Schoonderwaldt, Towards a Real-Time System for Teaching Novices Correct Violin Bowing Technique, 2009.
- [12] Mike Manser. (2007) ITS Institute. [Online]. <http://www.its.umn.edu/Publications/Sensor/2007/03/HapticFeedback.html>
- [13] Immersion Corporation. (2011) MOTIV. [Online]. <http://www.immersion.com/index.html>
- [14] (2011) Infiniti Technology. [Online]. <http://www.infinitiusa.com/technology/#/blind-spot-intervention/>

- [15] Luke Plunkett. (2010, June) Kotaku. [Online]. <http://kotaku.com/#!5576002/here-are-kinects-technical-specs>
- [16] Nicolas Burrus. (2010) Kinect Calibration. [Online]. <http://nicolas.burrus.name/index.php/Research/KinectCalibration>
- [17] (2011) Kids and Cars. [Online]. <http://www.kidsandcars.org/back-overs.html>
- [18] Roger N. Clark. (2009, November) ClarkVision.com. [Online]. <http://www.clarkvision.com/imagedetail/eye-resolution.html>