

## **Protection 3**

### **1.0 Introduction**

Recall there are five basic classes of relays:

- Magnitude relays
- Directional relays
- Ratio (impedance) relays
- Differential relays
- Pilot relays

We study the directional relay in these notes. This material addresses section 13.2 in your text.

### **2.0 Directional relays – Tripping Logic**

Directional relays have protection zones that include all of the power system situated in only one direction from the relay location. (This is in contrast to magnitude relays which are not directional, i.e., they trip based simply on the magnitude of the relay.)

Consider the one-line diagram in Fig. 1.

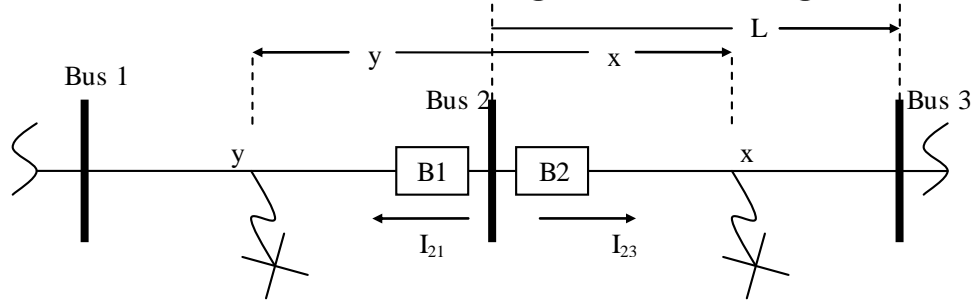

Fig. 1

If the relays R1 and R2 in Fig. 1 are directional relays, then

- R1 “looks” to the left but not to the right, and
- R2 “looks” to the right but not to the left.

In order to understand how the directional relay works, first, consider that R2 measures the phasors  $V_2$  and  $I_{23}$ . Now define the following parameters associated with Fig. 1:

- $L_{23}$ : length of circuit 2-3.
- $x$ : distance from R2 to a fault on circuit 2-3.
- $\lambda_x = x/L_{23}$ : the fraction of the circuit length between the relay R2 and the fault at point  $x$ .
- $I_{23}$ : the current in circuit 2-3 resulting from the fault  $x$  on circuit 2-3 (a phasor).
- $V_2$ : the bus 2 voltage (a phasor).
- $Z_{23}$ : total series impedance of circuit 2-3.

If a fault occurs on circuit 2-3, at point x, then the fraction of total circuit length between R2 and the fault is  $\lambda_x$ . If the circuit has uniform impedance per unit length, then the impedance between the relay R2 and the fault point is  $\lambda_x Z_{23}$ , and with the bus 2 voltage being  $V_2$ , the current flowing into circuit 2-3 from bus 2 is:

$$I_{23} = \frac{V_2}{\lambda_x Z_{23}} \quad (1)$$

But recall that for transmission lines, it is generally the case that  $R \ll X$ , and therefore

$$Z_{23} = jX_{23} \quad (2)$$

In that case, eq. (1) becomes:

$$I_{23} = \frac{V_2}{\lambda_x jX_{23}} \quad (3)$$

Recognizing that  $1/j = -90^\circ$ , eq. (3) becomes:

$$I_{23} = \frac{V_2}{\lambda_x X_{23}} \angle -90^\circ \quad (4)$$

Therefore  $I_{23}$  lags  $V_2$  by  $90^\circ$ .

Now if the fault occurs on circuit 1-2, at point y in Fig. 1, we can repeat the same analysis as eqs. (1)-(4), except for point y, where we use  $\lambda_{y=y}/L_{12}$ , The result will be

$$I_{21} = \frac{V_2}{\lambda_y X_{21}} \angle -90^\circ \quad (5)$$

But R2 measures  $I_{23}$ , not  $I_{21}$ . Reference to Fig. 1 results in the conclusion that

$$I_{23} = -I_{21} = \frac{-V_2}{\lambda_y X_{21}} \angle -90^\circ = \frac{V_2}{\lambda_y X_{21}} \angle 90^\circ \quad (6)$$

Therefore, in this case,  $I_{23}$  *leads*  $V_2$  by  $90^\circ$ .

From this simple analysis, we can establish a logic for the directional relay R1.

Define  $\theta_{23}$  as the angle of the phasor  $I_{23}$ , i.e.,

$$I_{23} = |I_{23}| \angle \theta_{23} \quad (7)$$

Then if we

- trip when current exceeds pickup AND  $\theta_{23} = -90^\circ$
  - and block if  $\theta_{23} = +90^\circ$ ,
- the relay will be directional.

In reality, of course, the circuits do have resistance, and so eq. (3), for a fault at point x, should be

$$I_{23} = \frac{V_2}{\lambda_x jX_{23}} = \frac{V_2}{\lambda_x Z_{23}} = \frac{V_2}{\lambda_x |Z_{23}|} \angle \theta_{23},$$

$$-90^\circ < \theta_{23} < -80^\circ$$
(8)

And eq. (6), for a fault at point y, should be:

$$I_{23} = \frac{-V_2}{\lambda_y Z_{21}} = \frac{V_2}{\lambda_y |Z_{21}|} \angle \theta_{23},$$

$$90^\circ < \theta_{23} < 100^\circ$$
(9)

Relations (8), (9) can be generalized as negative and positive angles, respectively. The current-plane representing the associated relay logic is in Fig. 2:

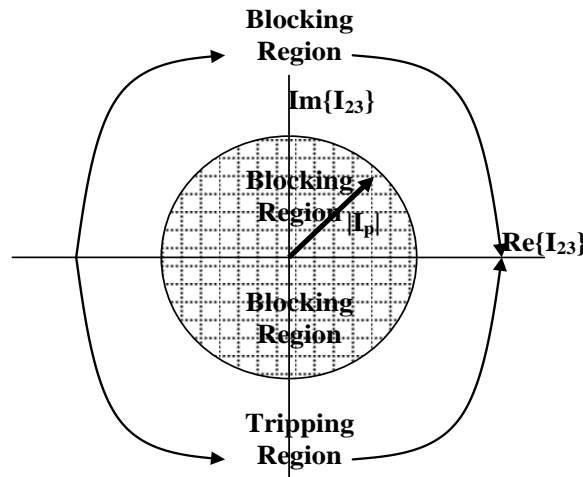

Fig. 2

The tripping logic can be stated for R2 as

$$-180 < \theta_{23} < 0, \text{ and } |I_{23}| > I_p \rightarrow \text{Trip}$$

$$0 < \theta_{23} < 180, \text{ or } |I_{23}| < I_p \rightarrow \text{Block}$$

where  $I_p$  is the pickup.

The tripping logic for R1 (which measures  $I_{21}$ ) would be:

$$-180 < \theta_{21} < 0, \text{ and } |I_{21}| > I_p \rightarrow \text{Trip}$$

$$0 < \theta_{21} < 180, \text{ or } |I_{21}| < I_p \rightarrow \text{Block}$$

### **3.0 Directional relays – when to use them**

Consider configurations where current flows from both ends of a circuit during a faulted condition. In such a case, you need breakers at both ends of the circuit because opening only one end will not isolate the fault.

For example, Fig. 3 illustrates a radial configuration having sources at both ends. Figure 4 illustrates a “single-loop” system.

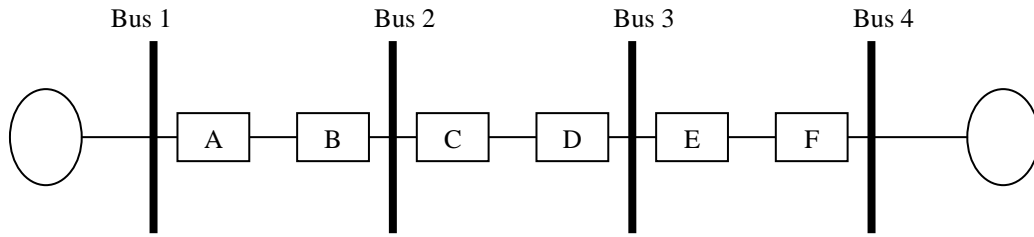

Fig. 3

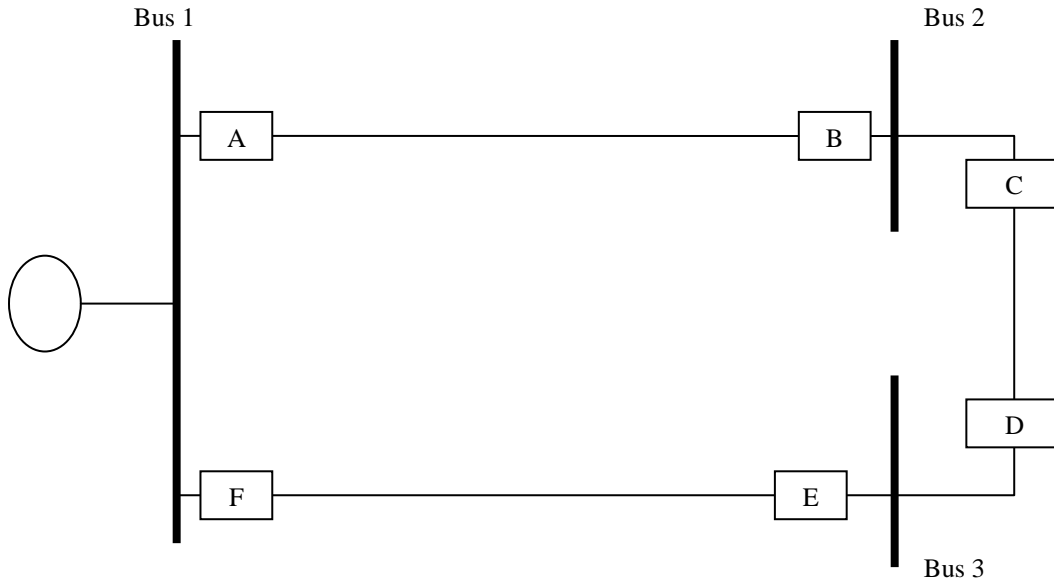

Fig. 4

One might consider using magnitude relays in these cases so that relays would open if current exceeded the pickup in either direction.

The problem is, however, that the magnitude relays are extremely difficult to coordinate in such configurations.

The following discussion applies to both.

For example, consider relay C. You might think to coordinate it with relay E, assuming that fault current comes from the bus 2 side, so that C is serving as the backup for E.

Based on the coordination approach given in the “Protection 2” notes, we would then set E to operate as fast as possible, for any fault that it sees. Then we would set C to operate more slowly for faults between E and F.

The problem with this scheme is, however, that because E is not directional, and because fault current flows from both ends, E sees faults between breakers C and D. Since E is set to operate as fast as possible, it may operate before D for a fault between C and D, thus unnecessarily de-energizing bus 3. Not cool.

The solution is to use directional relays with the various relays “looking” according to the arrows given in Figs. 5 and 6.



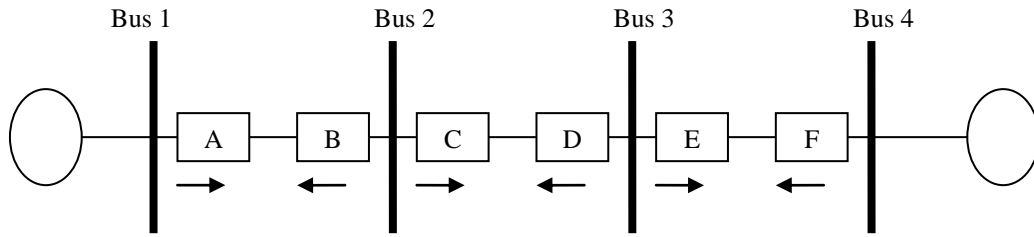

Fig. 5

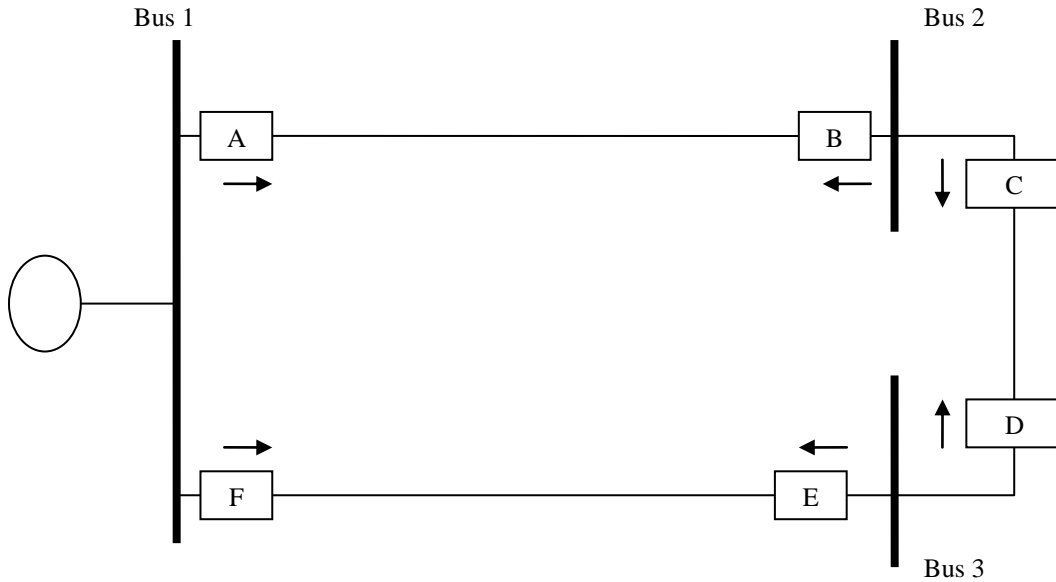

Fig. 6

Then you would coordinate relays

- A, C, and E together, assuming fault current is sourced only from the direction of relay A, and
- F, D, and B together, assuming fault current is sourced only from the direction of relay F.

## 4.0 The effects of distributed generation

Today, there is very high interest in the deployment of distributed generation (DG). DG is generation that is located in the distribution system. DG certainly includes rooftop solar, but it also includes other forms of generation, e.g., wind, gas-fired micro-turbines, diesel engines.

A large percentage of distribution load is served by radial feeders, just as we studied in the notes called “Protection2,” and as illustrated in Fig. 7 below.

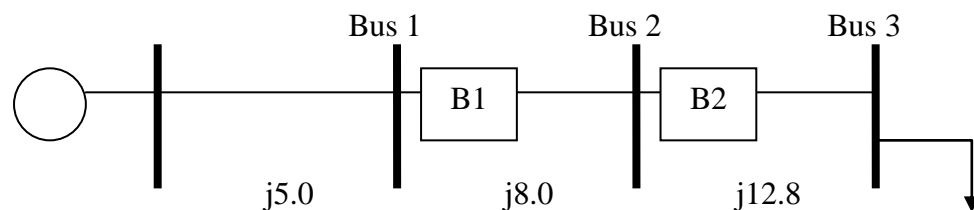

Fig. 7

Consider, however, the effects of providing a DG at bus 3, as illustrated in Fig. 8.

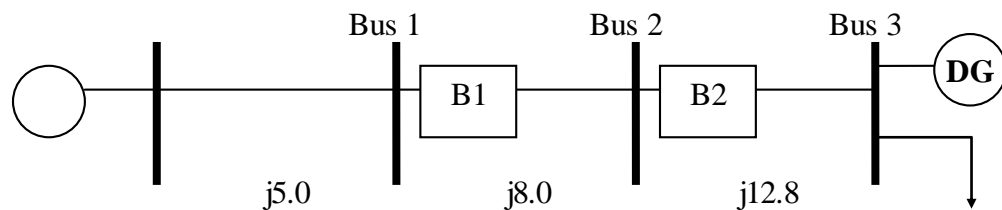

Fig. 8

When DG is installed on a radial distribution feeder, it is often the case that the feeder is protected by magnitude relays (non-directional overcurrent), but, as Fig. 8 shows, the DG may cause fault current to come from two directions. Therefore, DG installation on a radial feeder may require changes to the protection system so that

- Directional relays are used;
- Coordination for the entire protective system is revised to account for the directional relay characteristics.

I have found some recent IEEE papers that address this issue in some detail. Below are some excerpts from [1].

### Protection of distributed generation connected networks with coordination of overcurrent relays

Manjula Dewadasa, Arindam Ghosh and Gerard Ledwich  
Queensland University of Technology, Australia  
[j.dewadasa@qut.edu.au](mailto:j.dewadasa@qut.edu.au), [a.ghosh@qut.edu.au](mailto:a.ghosh@qut.edu.au), [g.ledwich@qut.edu.au](mailto:g.ledwich@qut.edu.au)

Most of the existing distribution systems are radial with unidirectional power flows from substation to customers [4]. Overcurrent protection is used for such systems because of its simplicity and low cost [1], [5]. However, once a DG or several DGs are connected within the main utility system, this pure radial nature is lost [2], [6]-[7]. Thus the protection of distribution networks using overcurrent protective devices becomes a challenging task due to the change in fault current levels and fault current direction [8]. This is because the protective devices may not respond in the way they were initially designed [5], [9].

When a fault occurs in a traditional radial feeder, the overcurrent relays respond to isolate the portion of the network resulting power interruption to the customers downstream from the fault location [15]. This customer power interruption can be minimized if DGs are allowed to supply power to the unfaulted portions in the network. To achieve this goal, the smallest possible portion of the faulted section should be isolated from the network. After the fault isolation, the DGs connected to the unfaulted sections can supply power to customers either in grid-connected or islanded mode depending on system configuration after the fault. In this case, only those customers connected to the faulted section will experience a power outage, if the DG capacity is sufficient to supply load power requirement in any islanded section. Also, islanded operation is desirable in the case of permanent faults which may take several minutes or hours to restore the system.

A faulted section can be isolated, if both upstream and downstream side protective relays respond in a DG connected radial system. In the grid connected mode, the upstream relay to a fault senses the fault current supplied by the utility, while the downstream relay to the fault senses the fault current supplied by all the downstream DGs. It is to be noted that the utility can temporarily supply a fault current that is much higher than its rated current. On the other hand, converter interfaced DGs limit the maximum current that they can supply. Therefore it can be surmised that the fault current seen by a particular relay in forward direction (i.e. when a fault occurs downstream to the relay) is much higher than it can see in the reverse direction. Therefore the relays must have the ability to distinguish between forward and reverse faults. It necessitates different relay settings in forward and reverse directions. Therefore directional overcurrent relays are proposed to isolate the faulted section.

## And some excerpts from [2].

# Future Distribution Feeder Protection Using Directional Overcurrent Elements

Doug Jones, *Member, IEEE*, and John J. Kumm, *Member, IEEE*

*Abstract*—Distribution feeder protection could soon be complicated by nonradial flows of real and reactive power available from high penetration distributed generation and potentially from microgrids. Nondirectional overcurrent protection may not provide necessary security and sensitivity for faults on remote points of the circuit. Directional supervision is necessary to set overcurrent pickups with adequate sensitivity for remote faults. Setting the directional element by traditional means provides a reliability risk at varying VAR flows within reach of specific types of distributed generation. This paper will demonstrate the limitations of nondirectional overcurrent protection and the pitfalls of an improperly configured directional element. A unique solution using directional overcurrent elements further secured by a load encroachment function can solve these problems. This approach has been validated in renewable plant collector circuit protection applications over a wide range of operating conditions.

*Index Terms*—Directional overcurrent, distributed generation, distribution protection, feeder protection, future distribution feeder, load encroachment, renewable feeder protection, smart grid, VAR control.

## I. INTRODUCTION

**D**ISTRIBUTION feeders with a high penetration of distributed generation will require different protection approaches than traditional nondirectional overcurrent elements. When interconnected generating sources provide fault current to the protected feeder, the substation relays' sensitivity is reduced. This will require the substation relay to be set as sensitively as possible to detect remote faults on the circuit. With this high degree of sensitivity, directional overcurrent elements will be necessary to prevent incorrect substation feeder relay tripping for faults on parallel feeders served by the distribution substation. Bi-directional power flow at the substation feeder connection can mean large swings in voltage and power factor during normal operation posing challenges for directional phase overcurrent elements, necessitating yet another level of supervision for greatest security. Experience with similar challenges on wind plant collector circuits suggests a solution for these potential problems. Make distribution protection upgrades with a view to these future protection challenges.

## II. PRESENT AND FUTURE DISTRIBUTION FEEDER CHARACTERISTICS

A typical distribution feeder circuit consists of a main, three-phase trunk circuit having single-phase and/or three-phase lateral taps to serve loads away from the feeder route. For higher ampacity, conductors near the substation are frequently larger than lateral and remote conductors. Laterals and remote feeder sections are often protected by fuses or automatic reclosers. Nondirectional overcurrent elements at the substation and within the reclosers have been adequate for traditional feeder protection. Development of multi-function overcurrent relays having negative-sequence nondirectional overcurrent elements relieved some compromises caused by heavy line loading [1]. Loads are served radially, with normal and fault current flowing from the substation out to the load/fault.

Interest in and practicality of distributed generation has increased steadily. More recently, microgrid development has been discussed to locally aggregate loads, storage, and generation with utility service to meet a variety of objectives. The possibility of wheeling real and reactive power across the distribution substation bus cannot be far off.

Adding sources to distribution feeders creates substantial protection challenges that often cannot be adequately addressed by nondirectional overcurrent protection alone. Consideration of another medium-voltage protection application having similar characteristics to the future distribution feeder is instructive.

- 
- [1] M. Dewadasa, A. Ghosh, and G. Ledwich, "Protection of distributed generation connected networks with coordination of overcurrent relays," IECON 2011 - 37th Annual Conference on IEEE Industrial Electronics Society. DOI: 10.1109/IECON.2011.6119434, 2011, pp. 924-929.
- [2] D. Jones and J. Kumm, "Future distribution feeder protection using directional overcurrent elements," IEEE Transactions on Industry Applications, Vol. 50, No. 2, March/April 2014.