

"Energy Systems" A Critical National Infrastructure Slide Deck #1

James D. McCalley

Professor of Electrical and Computer Engineering
Iowa State University Ames, IA

WEBPAGE:

<http://home.engineering.iastate.edu/~jdm/ee303/ee303schedule.htm>

HELPFUL BOOK:

<https://onlinelibrary-wiley-com.proxy.lib.iastate.edu/doi/book/10.1002/9781119994404>



National Academy of Engineering rankings for greatest engineering achievement of the 20th Century. Criteria: transformation of human life.

- 2 ♦ Automobile
- 9 ♦ Telephone
- 6 ♦ Radio/television
- 11 ♦ Interstate highways
- 1 ♦ Electrification
- 13 ♦ Internet
- 12 ♦ Spaceflight
- 19 ♦ Nuclear technologies
- 5 ♦ Electronics
- 8 ♦ Computer
- 3 ♦ Airplane
- 4 ♦ Water supply

See www.greatachievements.org

Content of these slides

- ◆ Evolution of electricity industry
- ◆ Integrated electric energy systems
- ◆ Power systems: how they work
- ◆ Power systems: what can go wrong?
- ◆ The 2003 NE Blackout
- ◆ The future of energy

Evolution of Electric Industry



1600: William Gilbert invents the compass.

1732: Stephen Gray discovers conduction..

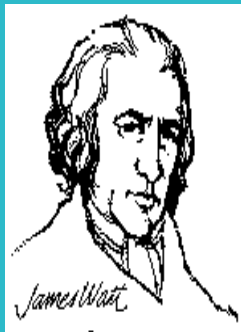

1736: James Watt invents steam engine.

1745 Musschenbroek invents Leyden jar (capacitor)



1752: Ben Franklin proves lightning is electricity

1785: Charles Coulomb discovers relation between force and charge.

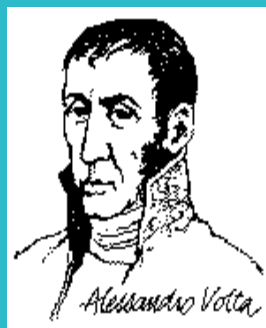

1792: Alessandro Volta invented the battery.

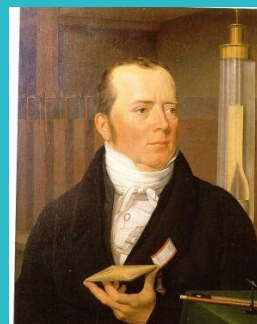

1820: Hans Oersted discovered magnetic effects of a current on a compass needle.



1820: Marie Ampere discovered a coil of wire acts like a magnet when carrying current.

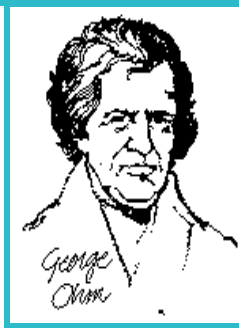

1827: George Ohm discovered the relation between voltage, current, and resistance.

1827: Joseph Henry discovered inductance.



1831: Michael Faraday discovered Faraday's law and invented the generator

1835: Johann Gauss related magnetic flux & electric charge.



1845: Gustav Kirchoff developed laws enabling the efficient calculation of currents in complex circuits.



1855: Wilhem Weber defined units for current and resistance.

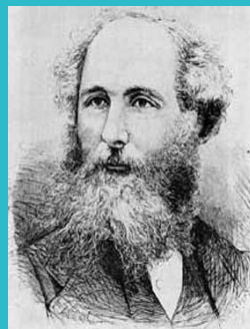

1873: James Maxwell wrote equations describing electro-magnetic fields, and predicted the existence of electromagnetic waves.



1879: Edison invented the incandescent lamp and in 1882 supplied Pearl St (NY) with light from DC generator.

1886: William Stanley invented the transformer.

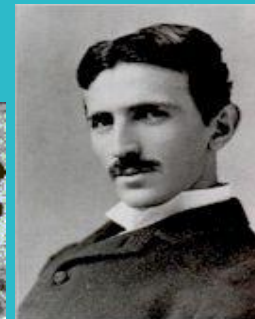

1888: Nikolai Tesla patented the AC polyphase motor.

1888: H. Hertz experimentally verified Maxwell's equations

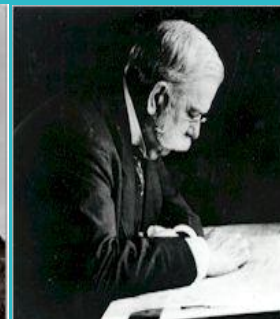

1895: George Westinghouse harnessed Niagara Falls and commercialized AC generation, transformation, and transmission.

Evolution of Electric Industry

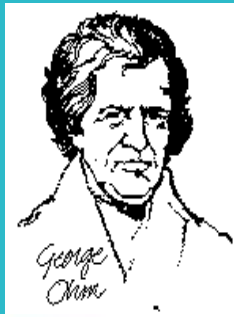
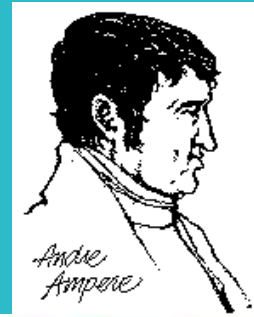
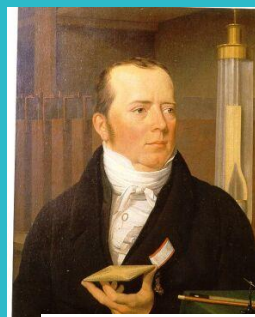
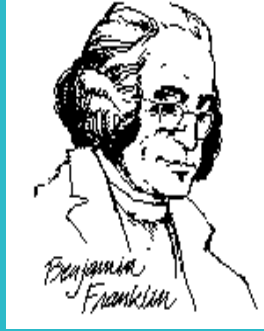
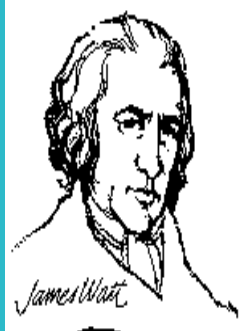

1600: William Gilbert invents the compass.

1732: Stephen Gray discovers conduction..

1736: James Watt invents steam engine.

1745 Musschenbroek invents Leyden jar (capacitor)

1752: Ben Franklin proves lightning is electricity

1785: Charles Coulomb discovers relation between force and charge.

1792: Alessandro Volta invented the battery.

1800: Galvani discovered the effect of a c...



George Ohm defined the relationship between current, voltage, and resistance. Ohm's law covered...



Niagara Falls realized AC

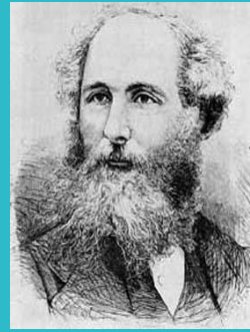
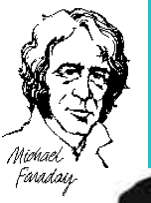

1831: Michael Faraday discovered Faraday's law and invented the generator

1835: Johann Gauss related magnetic flux & electric charge.

1845: Gustav Kirchoff developed laws enabling the efficient calculation of currents in complex circuits.

1855: Wilhem Weber defined units for current and resistance.

1873: James Maxwell wrote equations describing electro-magnetic fields, and predicted the existence of electromagnetic waves.

1879: Edison invented the incandescent light bulb

1886: William Stanley invented the transformer.

verified Maxwell's equations

transformation, and transmission.

Evolution of Electric Industry

- ◆ 1903 Samuel Insull understanding **economies of scale** (generators when scaled up produce power at a lower \$/kWhr – big is better!) installs 5 MW generator in Chicago and manages load to increase his **load factor** (avg load/max load) to increase profits
- ◆ 1907 Insull realizes that profitability from managing economies of scale and load factor grows with corporate size, and so forms Commonwealth Edison, Chicago, by buying all of his competitors.
- ◆ 1907 States begin recognizing electric companies as **natural monopolies** similar to the railroads, with large economies of scale requiring huge capital investment so that it was not socially efficient to have multiple competitors



Steam turbo-generators,
Long Island railways, c.1907



Fiske Street Station steam turbine
Chicago, c.1907

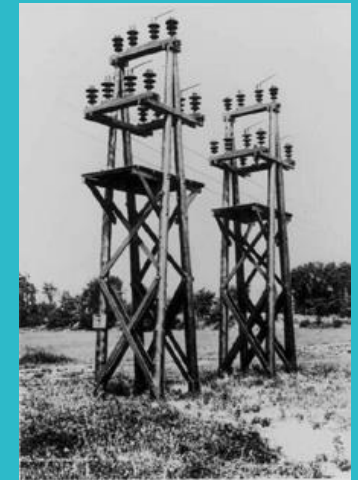

Transmission switches
on wooden towers, 1906

Evolution of Electric Industry

- ◆ 1914 About 43 states had established government oversight (**state regulation**) of electric utilities, requiring reliability and the **obligation to serve** from utilities, and giving right to recover **reasonable return** from the **rate base** on their investments, contributing to perspective that utility stocks were good for retirement.
- ◆ 1920, Congress established the Federal Power Commission (FPC) to coordinate hydroelectric projects under federal control.
- ◆ 1927 In US, 75,400 MWhr sold, from 5700 MWhr in 1907
- ◆ Equipment manufacturers (GE) started **holding companies** that would buy and manage many **operating companies**, offering them equipment and services that they could not afford themselves, & establishing **interconnections** between them.

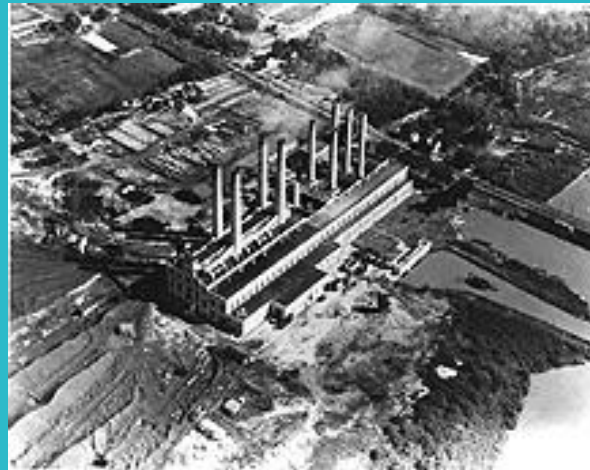

Potomac Electric Power Co.
power station near Washington DC, 1939

Evolution of Electric Industry

- ◆ 1927 There were 4400 operating companies, 180 holding companies; top holding companies in **pyramids** often overcharged subsidiary (operating) companies.
- ◆ 1929 Stock market crash caused loss among holding companies; a few survived
- ◆ 1932 Only 8 holding companies owned 75% of the operating companies, & they were exempt from state regulation since their business crossed state boundaries.
- ◆ 1932 FDR elected on promise to reform the industry of “the Ishmaels and the Insulls, whose hand is against everyman's.”
- ◆ 1935 Investor-owned utilities (**IOUs**) resisted supplying rural areas on grounds it would not be profitable. So US Rural Electrification Administration created to facilitate creation of municipals and co-operatives in rural areas.
- ◆ 1935 Public Utility Holdings Company Act (PUCHA)
 - Broke up layered interstate holding companies; allowed 1 level above operating company; required them to divest holdings that were not within a single circumscribed geographical area; reduced existing monopoly power.
 - Required companies to engage only in business essential for the operation of a single integrated utility, and eliminated non-utility generators (NUGs-didn't want companies moving into other areas); reduced future monopoly power.
 - Required companies to register with Security & Exchange Commission (SEC)₈

Evolution of Electric Industry

- ◆ 1938-1964: Golden years!
 - Holding companies declined from 216 to 18.
 - Generator max plant efficiencies increased from ~20% to ~40%.
 - Generation max size increased from ~110 MW to ~1000 MW.
 - Transmission typical voltage increased from mostly 60 kV to 230, 345, and 500 kV.
 - Load grew at ~8%/year, doubling every 10 years.
 - Price declined at 50 cents/kWhr to 10 cents/kWhr.
 - Grow and build!
- ◆ 1964 About 77% electric energy from IOUs and 23% from municipals, co-ops, and government (e.g., WAPA, BPA, TVA).

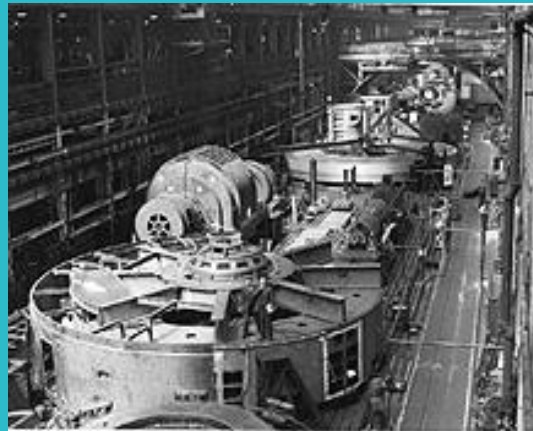

45,000 Kilovolt-ampere waterwheel
for Tennessee Valley Authority
(foreground), c.1938

Evolution of Electric Industry

- ◆ 1965, 5:27 pm, Nov 9: Northeast Blackout, 20000 MW lost, 80,000 people interrupted in northeast US, including NYC.
- ◆ 1968 North American Electric Reliability Corporation (**NERC**) created.

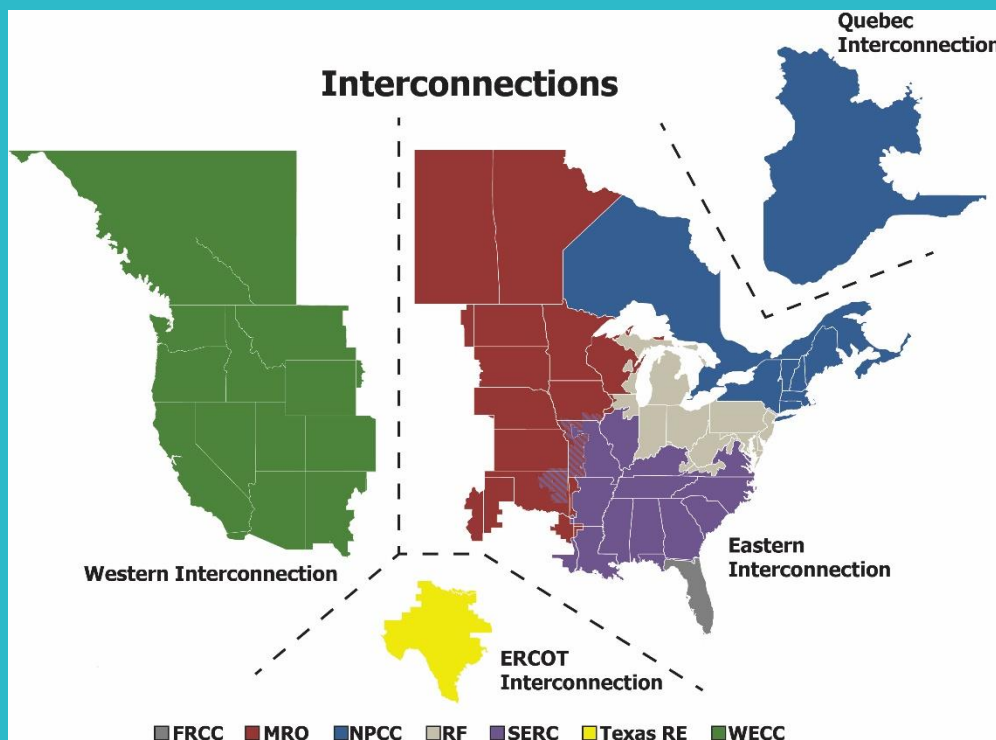
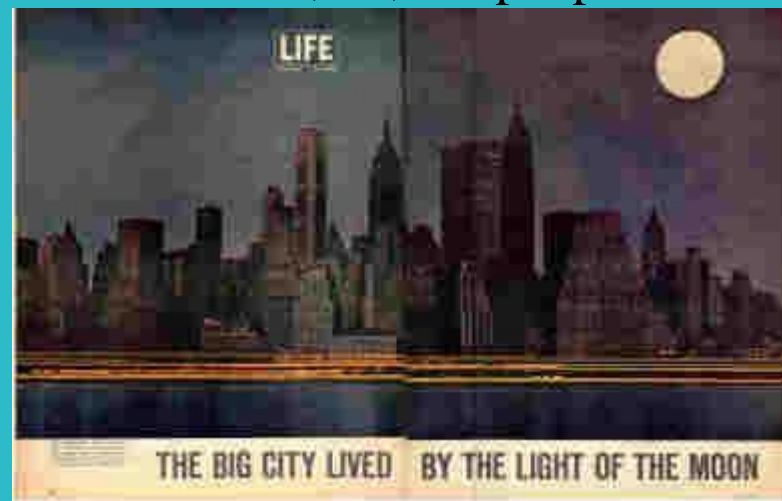

Evolution of Electric Industry

- ◆ 1970 Technical limits to economies of scale and to plant efficiencies, aversion to coal due to cheap petroleum and nuclear, & OPEC.
- ◆ 1973 Energy Crisis
- ◆ 1977 Department of Energy (DOE) created to address US policies regarding energy and safety in handling nuclear material

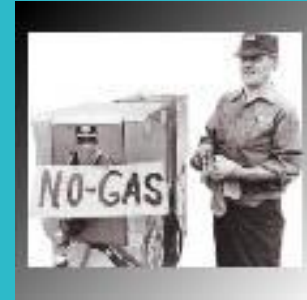

- ◆ 1977, FPC changed to FERC (regulates transmission and wholesale markets for interstate commerce).



“the moral equivalent of war.”



Schwappe initially called it “homeostatic control,” The word homeostasis combines forms of homeo, “similar,” and stasis, “standing still,” yielding “staying the same.”

- ◆ 1978, Airline industry deregulated

- ◆ 1978 Public Utility Regulatory Policies Act (PURPA): utilities had to interconnect, buy, at avoided cost from qualifying facilities (small power producers using 75% renewables or cogeneration).



- ◆ 1978: Fred Schwappe at MIT proposed “spot pricing” of electricity
- ◆ 1979 Three-mile island accident.
- ◆ 1987 Non-utility generation grows →

MAJOR QUESTION: Are electric utilities natural monopolies?

Evolution of Electric Industry

◆ 1992 Electric Policy Act

- Exempt Wholesale Generators: class of unregulated generators of any technology, utilities did not have to buy their energy.
- But utilities did have to provide transportation (**wheeling**) for wholesale transactions; no rules were specified regarding transmission service price.

U. S. Average Retail Price per Kilowatthour is 8.90 Cents

2017 U.S. Average Electricity Retail Prices (cents per kilowatt hour)

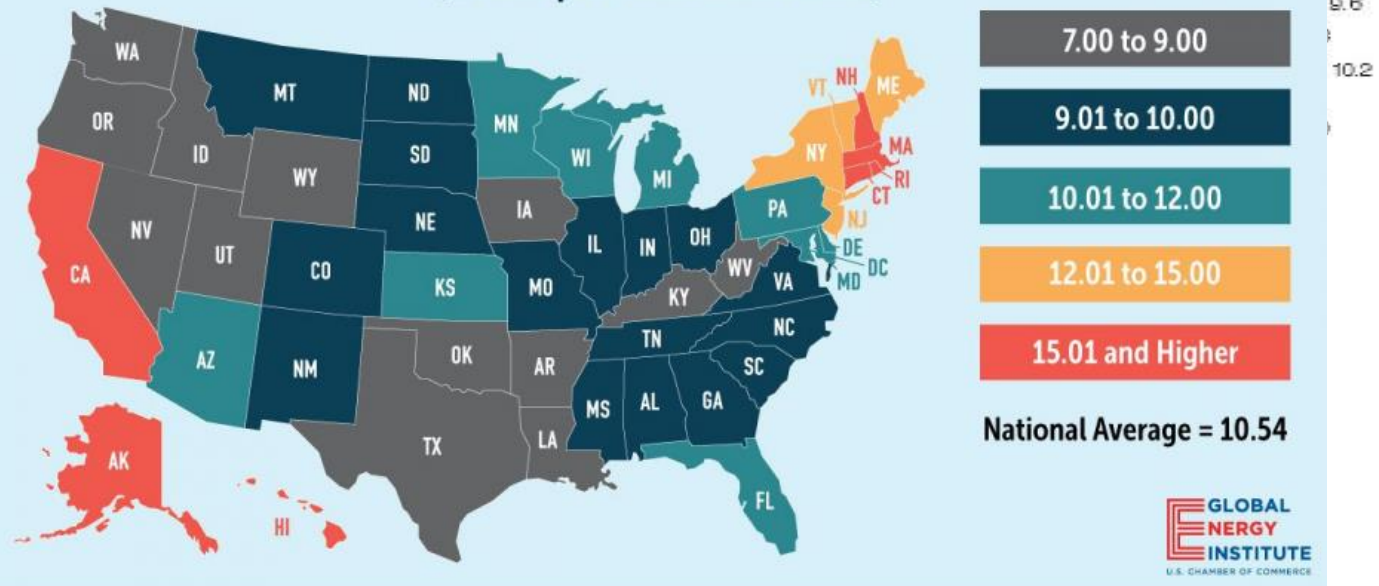

The 1992 EPA motivated by price disparity throughout the US. Large industrials were hungry for lower prices.

Evolution of Electric Industry

- ◆ 1996 FERC Orders 888, 889, required IOUs to
 - file nondiscriminatory transmission tariffs
 - pay tariffs for transmission service for their own wholesale transactions
 - maintain an information system that gives equal access to transmission information (**OASIS**)
 - functionally **unbundle** their generation from “wires”
 - FERC order did not specify how; can be done via divestiture or “in-house”
- ◆ Major outages: WSCC ('96,'97), Bay area ('98), NY ('99), Chicago ('00)
- ◆ 1997: Startup of 21 OASIS nodes across US
- ◆ 1998 (April) California legislation gave consumers right to choose supplier
 - 1999 (June) 1% residential, 3% small commercial, 6% commercial, 21% large industrial, 3% agricultural have switched providers in California
 - 2000 (Jan) 13.8% of total load switched in Cal
- ◆ 1996-2002: Independent System Operators begin: PJM, ISO-NE, ERCOT, CALISO, NYISO, MISO, SPP. ISOs own no transmission but are responsible for operating and planning the grid, and operating electricity markets. Most ISOs also obtained RTO status (see next slide).

Transmission and System Operator

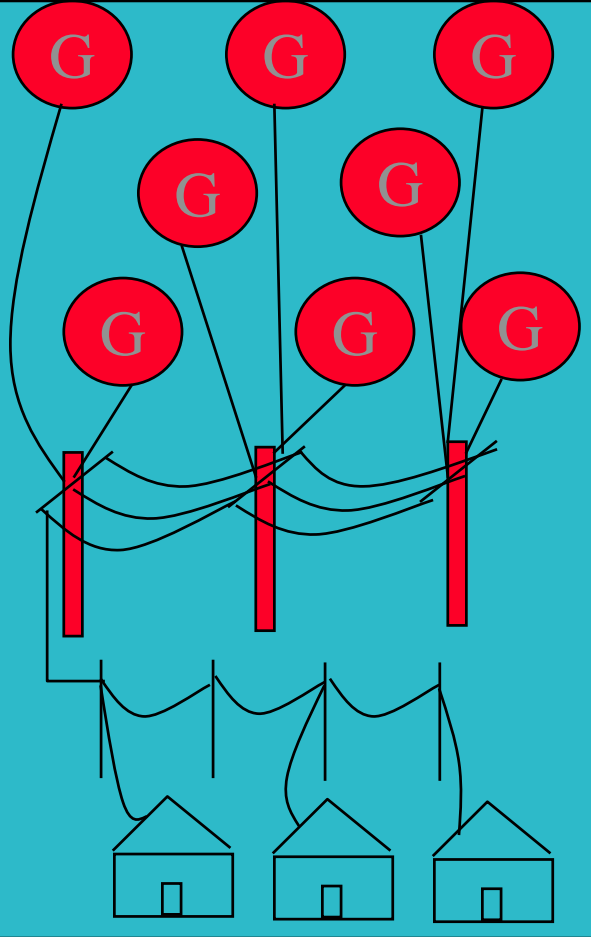

Vertically Integrated Utility

1900-1999?

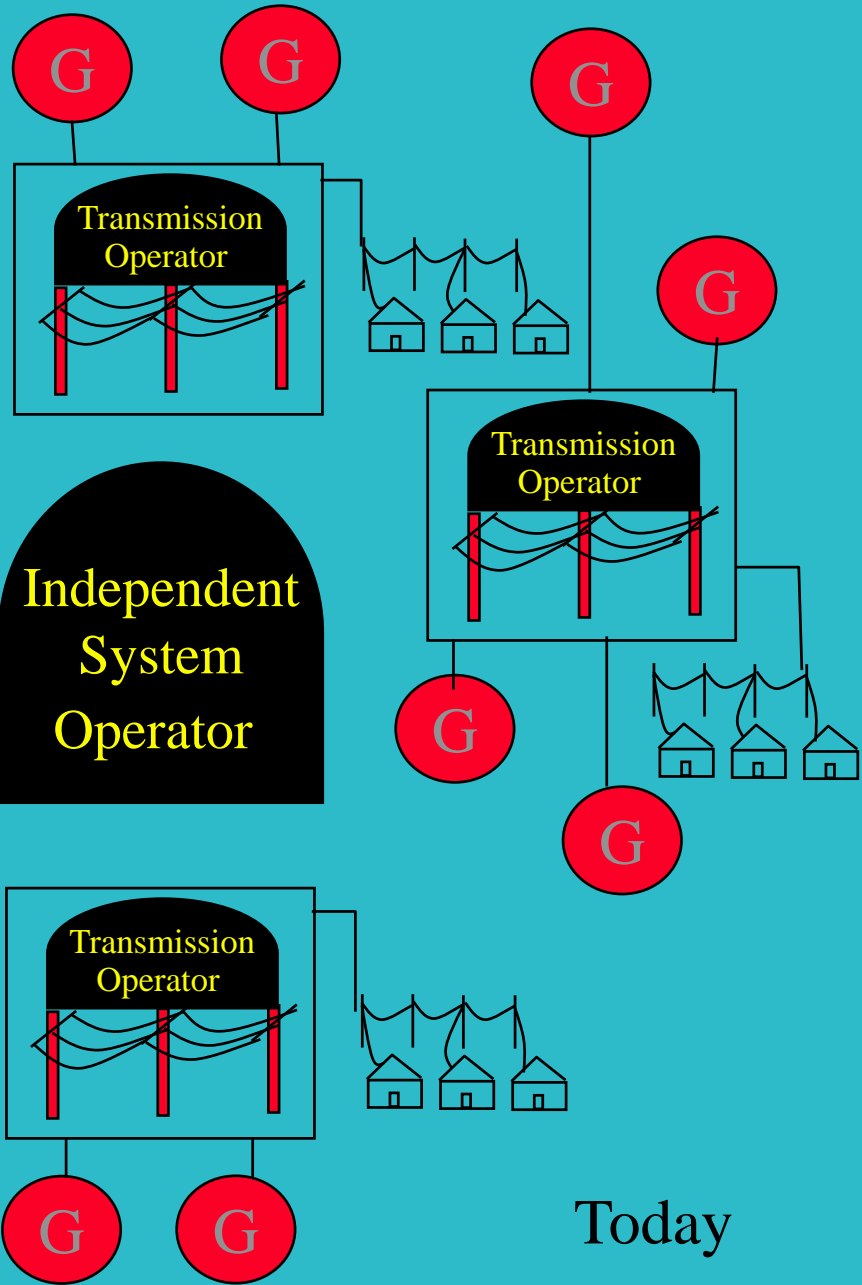

Today

Evolution of Electric Industry

- ◆ 2000 FERC Order 2000 formalized operating, planning, market functions and also required significant regional size to become a regional transmission organizations (RTO). US ISOs subject to FERC jurisdiction (not ERCOT) that satisfy a list of requirements become RTOs.

- ◆ 2000-2001 California energy crisis

- Drought, hot weather, outaged generation, natural gas shortage, transmission bottlenecks, flawed market design allowing price manipulation by some companies, problematic political forces

- ◆ 2001, April PG&E went bankrupt



- ◆ 2001, November Enron collapse (<https://www.enr.com/resources/stories/2001/11/01-enron-collapse>)
- ◆ 2002 FERC standard market design issued.
- ◆ 2003 Major blackout in the northeast US

Seeking Alpha Portfolio People News Analysis

Energy | On the Move | Top News

PG&E to file for Chapter 11 bankruptcy

Jan. 14, 2019 7:05 AM ET | About: PG&E Corporation (PCG) | By: Carl Surran, SA News Editor

- PG&E (NYSE:PCG) says it is preparing to file for Chapter 11 bankruptcy to "support the orderly, fair and expeditious resolution of its potential liabilities resulting from the 2017 and 2018 Northern California wildfires."



Evolution of Electric Industry

- ◆ 2004, First large wind farm in Iowa (160.5MW Intrepid plant in NW Iowa)
- ◆ 2005, National Energy Policy Act: Quotas on ethanol, \$\$ for clean coal R&D, large incentives to build nukes, repeals PUCHA (SEC authority to FERC).
- ◆ 2006, “An inconvenient truth” (Al Gore) about global warming

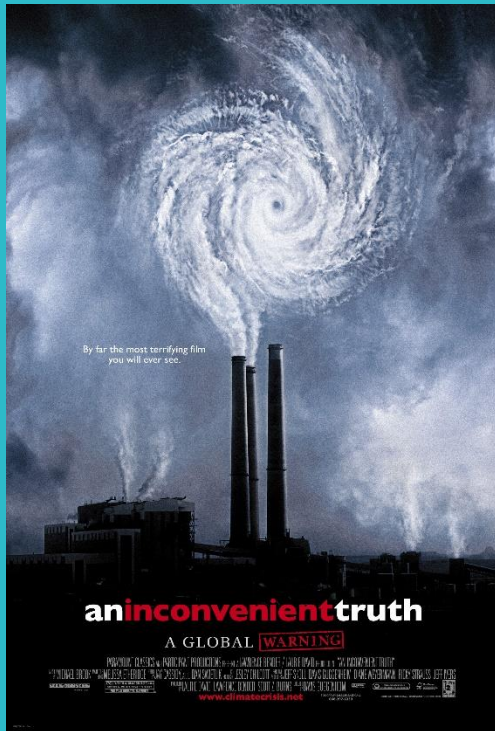
The image is a screenshot of an email client window. The window title is 'Climate change's first major financial casualty | U.S. Energy News - Tuesday, January 15 - Message (HTML)'. The email is from 'U.S. Energy News <editor@energynews.us>' to 'McCalley, James D [E CPE]'. The subject is 'Climate change's first major financial casualty | U.S. Energy News - Tuesday, January 15'. The email body contains a date 'Tuesday, January 15, 2019', a large 'U.S. ENERGY NEWS' logo, a tracking link, and a 'StorageWeek' advertisement for a summit in San Francisco, CA. The advertisement includes the text 'Sign Up for The Summit that will Drive Energy Storage Project Development and Finance' and a 'Register Now' button. Below the advertisement, the text reads 'CLIMATE: • Energy experts say [PG&E's bankruptcy filing](#) is one of the first major financial casualties from climate change, and won't be the last. (New York Times)'. The Windows taskbar is visible at the bottom of the screenshot.

“The effects of global warming on temperature, precipitation levels, and soil moisture are turning many of our forests into kindling during wildfire season.”

7/24/18, Union of Concerned Scientists, www.ucsusa.org/global-warming/science-and-impacts/impacts-global-warming-and-wildfire.html#_XD4ZYLxKq2w

Evolution of Electric Industry

- ◆ 2008, Economic depression, Obama elected
- ◆ 2009, In response to depression Obama initiated the American Recovery and Reinvestment Act of 2009, which included \$80B “energy money” as follows:
 - \$3.4B for smart grid investment
 - Launched the Advanced Research Projects Agency (ARPA-E) to fund innovative energy concepts
 - Imposed new efficiency standards for home appliances
 - Imposed fuel efficiency policies for cars
 - Increase production of biofuels
 - Required reporting of greenhouse emissions by power plants
- ◆ 2010, Obama proposed an energy security plan to reduce offshore energy need
- ◆ 2011, Obama state of union: 80% of US electricity from clean sources by 2035
- ◆ 2015, Obama’s EPA: Clean Power Plan to lower power plant CO₂ emissions
- ◆ 2016, 2/3 electric utilities support CPP, but congressional & legal pushback abounds
- ◆ 2016, Trump elected
- ◆ 2017, US withdraws from Paris Agreement
- ◆ 2018, Trump proposes Affordable Clean Energy Rule, giving CO₂ authority to states

Integrated Electric Energy Systems

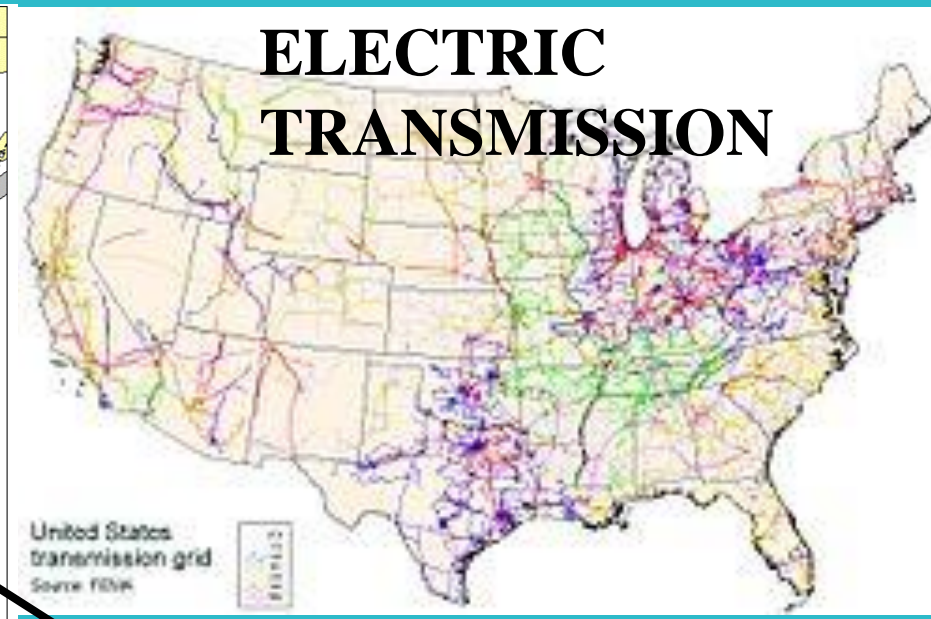
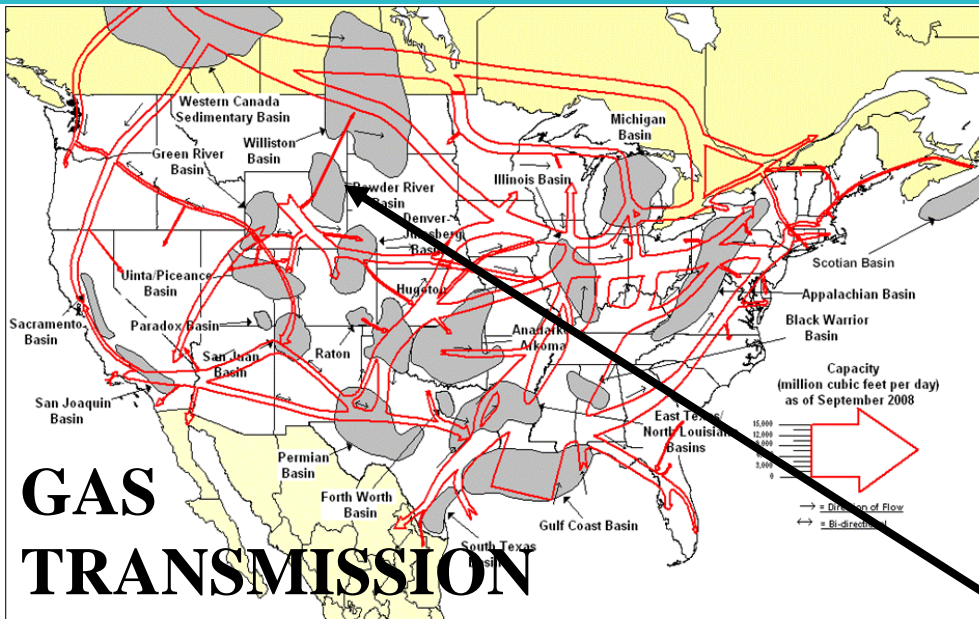

Source: Energy Information Administration, Office of Oil and Gas, Natural Gas Division, Gas Transmission Information System



Source: U.S. Energy Information Administration based on data from various published studies. Updated: April 13, 2015

The grid: High-level view

Basic Structure of the Electric System

Color Key:
Blue: Transmission
Green: Distribution
Black: Generation

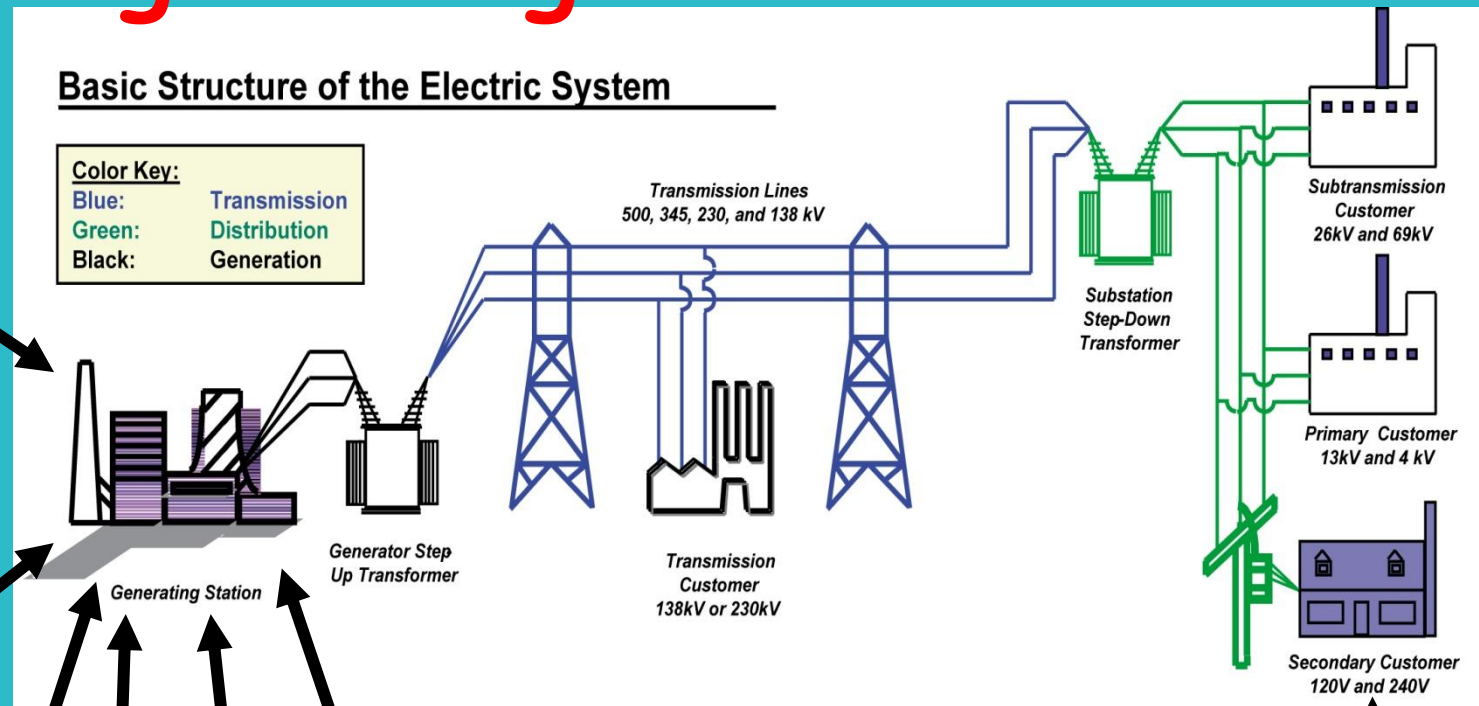

Hydro



CT or CC

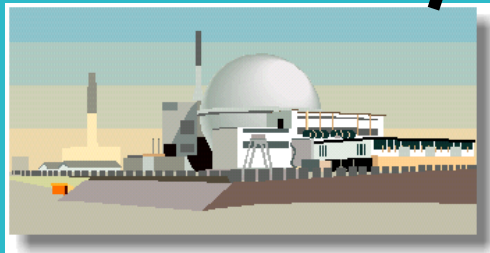

Nuclear



Coal



Wind



Utility solar PV



Distributed generation (rooftop solar)

US Generation mix

	2000	2008	2010	2015	2016	2018
FOSSIL						
OIL	1.9%	1.6%	1.0%	0.8%	0.7%	0.7
COAL	57%	49%	45%	33%	30%	27%
NAT GAS	10%	20%	23%	33%	34%	34%
OTHER GAS		0.4%		0.5%	0.5%	0.5
NUCLEAR	23%	19.4%	20%	20%	20%	19%
RNWBLES						
HYDRO	7.5%	7%	7%	6%	6%	6.8%
WIND	0%	0.6%	1.8%	4.7%	5.6%	8.3%
SOLAR	0%	0.1%	0.1%	0.6%	0.9%	1.5%
BIOMASS	0.2%	1.3%	1.5%	1.6%	1.6%	1.7%
GEOTRML	0.4%	0.4%	0.4%	0.4%	0.4%	0.4%
Coal+gas+wind	67%	69.4%	69.8%	70.7%	69.6%	69.3%

Power System Basics

- ◆ Current (amperes), is like water flow
- ◆ Voltage (volts), is like water pressure
- ◆ Resistance (ohms), is like 1/pipe diameter: $I=V/R$
- ◆ Electricity is either DC or AC

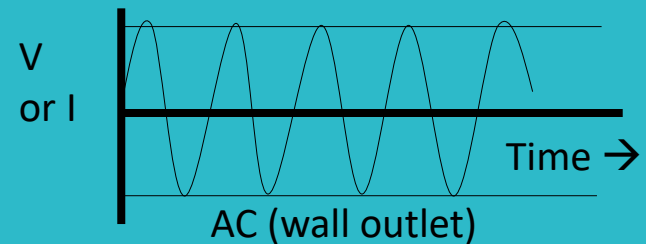
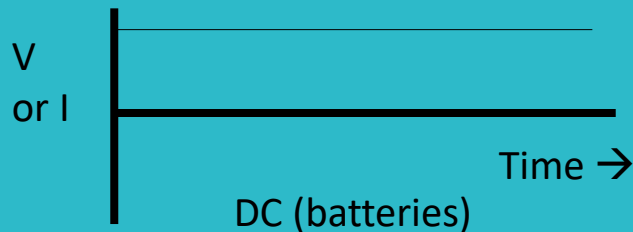

- ◆ Real power (watts), is ability to do work, light a bulb
 $P=3VI\cos\theta$
- ◆ Reactive power (vars), does no work, but anything with a winding (motor) must have them. $Q=3VI\sin\theta$

Power System Basics

AC voltages can be easily changed from one level to another using power transformers.

Power generation occurs at low voltages ($<30,000$ volts) because of insulation requirements.

Power transmission occurs at high voltages (69,000 to 765,000 volts) to minimize current for given power transfer capability and thus minimize losses in wires.

Power distribution occurs at low voltages ($\leq 34,500$ volts) for safety reasons

So power systems are mainly AC because of ability to easily transform AC voltages from low levels in the generators to high levels for transmission and back to low levels for distribution and usage.

Power System Generation & Transmission

- ◆ Power circuits can be single-phase or 3-phase

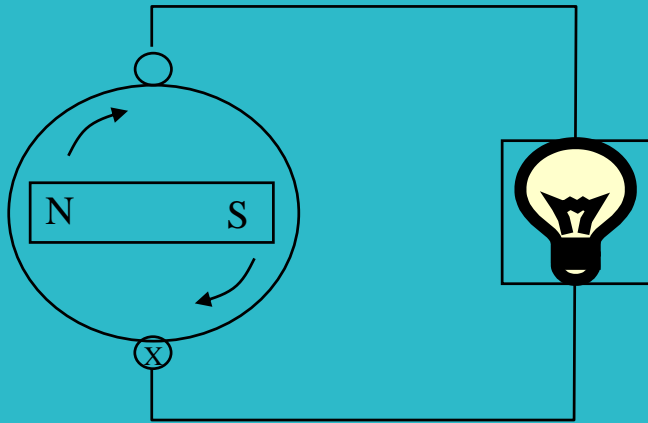

Single phase

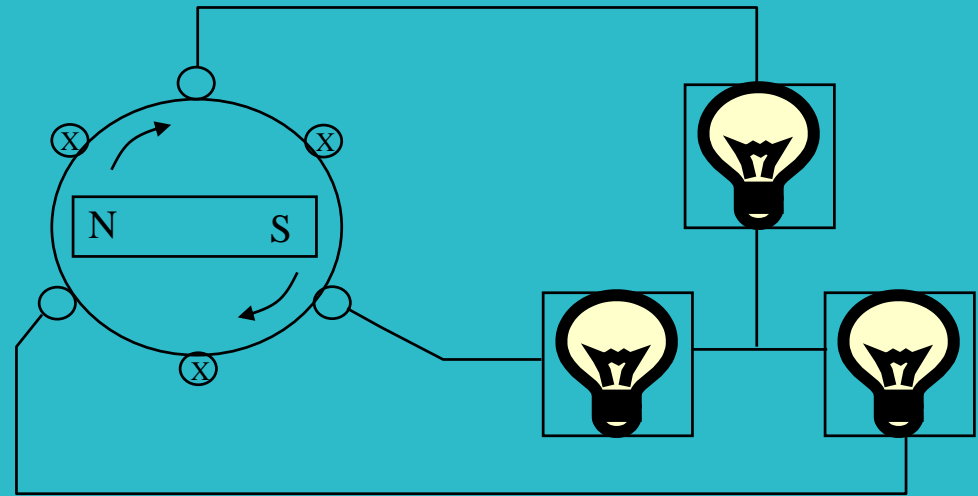

3-phase

- ◆ Generation & transmission is always 3-phase because
 - Gives the same power but requires 3 wires instead of 6
 - Power is constant and large motors run smoother

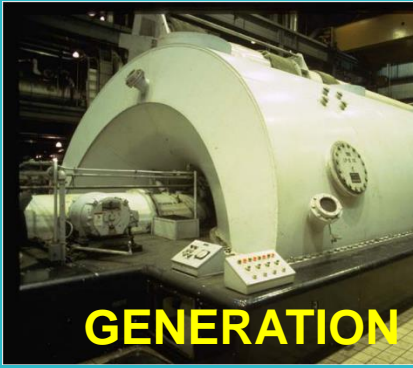

GENERATION



Repairs to the overhead insulation of this 200MW generator rotor were carried out by experienced tradesmen working on shift to ensure the earliest possible return to service.



DISTRIBUTION



TRANSMISSION



SUBSTATIONS

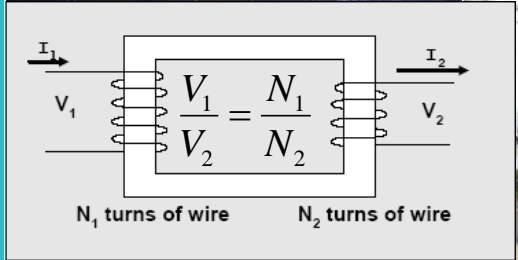

TRANSFORMERS

US Electric Transmission & Control System

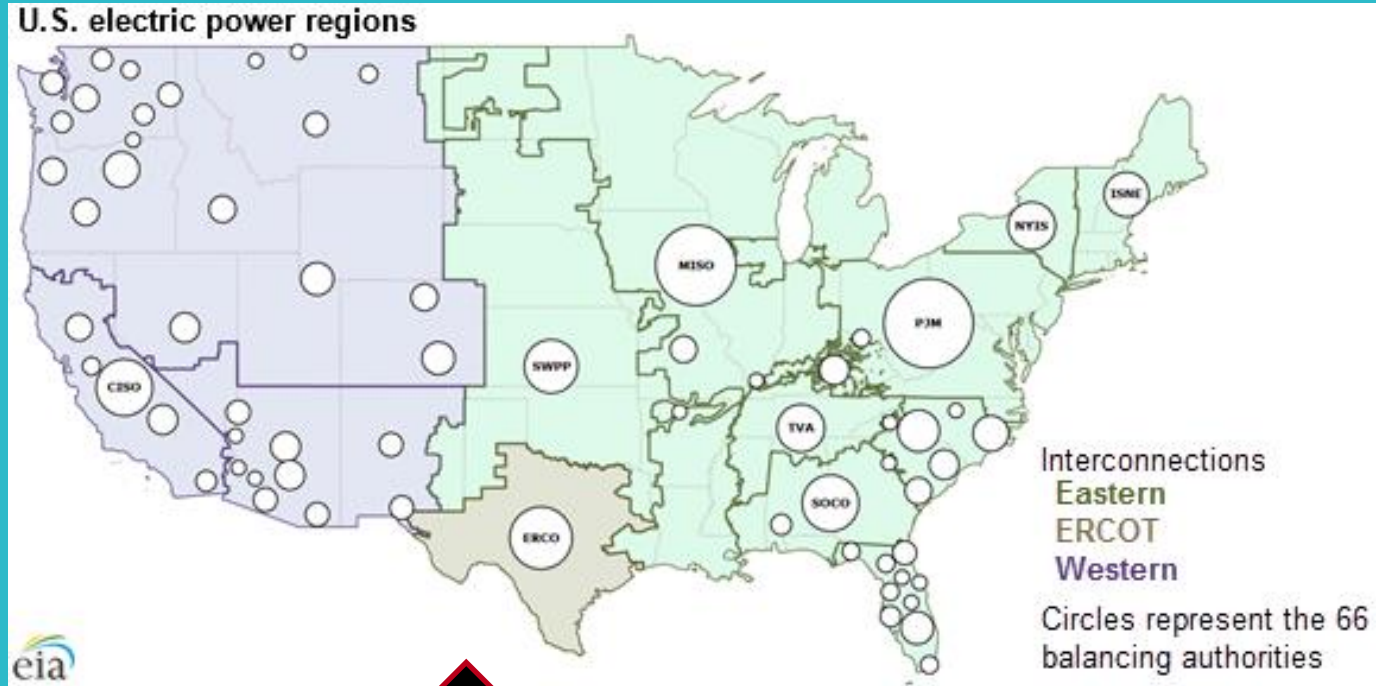

Balancing authorities (the circles): ↑
They all perform power balancing.
And they all have energy control centers.
CAISO, ERCOT, SPP, MISO, PJM, NYISO,
and ISONE also operate markets.

US Transmission System:
69, 115, 138, 161, 230, 345, 500, 765 kV
and HVDC (mostly ± 500 kV) →

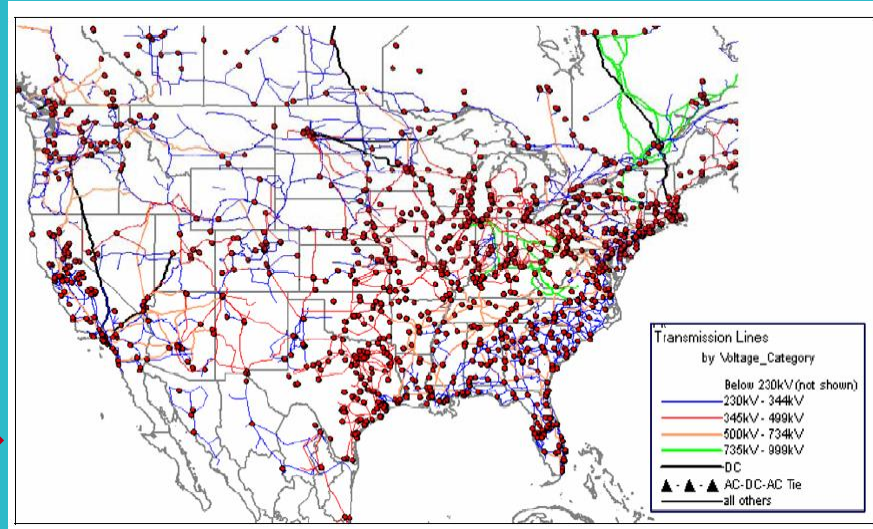

Remote terminal unit



Substation

Communication link

SCADA Master Station



Energy control center with EMS

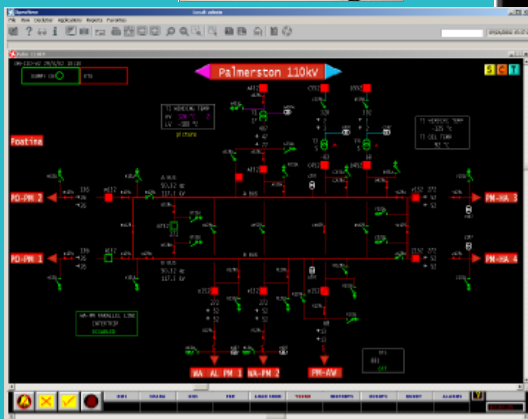

No.	EventTime	Single	Description	Event	Value
81	07/23/02 13:44:06	HORSELAKE 120kV HEL 230kV BRKT-100kV L 1W		RETURN HIGH LIMIT 3	507.8
82	07/23/02 13:44:07	MUSKOGEE 345kV MUSK 345kV UNIT 6 MW MW		HIGH RESPONSABILITY EXCEEDED	513.5
83	07/23/02 13:44:07	MUSKOGEE 345kV MU 345 PRTTBUSLINE LINE MW		RETURN HIGH LIMIT 1	1801.7
84	07/23/02 13:44:07	MUSKOGEE 345kV MU 345 90k AD SHP 3842 MW		RETURNED TO NORMAL	1801.7
85	07/23/02 13:44:07	HORSELAKE 120kV HEL 120kV FENG LINE MWTT MW		RETURN HIGH LIMIT 3	153.8
86	07/23/02 13:44:07	MTR SHP SHP SHP 1 TEST FCST1 10 MW		RETURN HIGH LIMIT 1	115.0
87	07/23/02 13:44:06	MUSKOGEE 345kV MUSK 345 90k AD SHP 3842 MW		LOW RESPONSABILITY EXCEEDED	1585.4
88	07/23/02 13:44:06	MTR SHP SHP SHP 1 TEST FCSTP 6 MW		HIGH RESPONSABILITY EXCEEDED	161.8
89	07/23/02 13:44:06	MTR SHP SHP SHP 1 TEST FCST1 8 MW		HIGH RESPONSABILITY EXCEEDED	161.8
90	07/23/02 13:44:06	MUSKOGEE 345kV MUSK 345kV UNIT 6 MW MW		LOW LIMIT 3 EXCEEDED	507.7
91	07/23/02 13:44:04	MUSKOGEE 345kV CLARK345kV LINE A PH MW		HIGH RESPONSABILITY EXCEEDED	1514.3
92	07/23/02 13:44:04	MUSKOGEE 345kV MU 345 PRTTBUSLINE LINE MW		HIGH LIMIT 3 EXCEEDED	1781.8
93	07/23/02 13:44:03	MUSKOGEE 345kV MUSK 345kV UNIT 6 MW MW		HIGH RESPONSABILITY EXCEEDED	1287.4
94	07/23/02 13:44:03	HORSELAKE 120kV HEL 120kV FENG LINE MW		HIGH RESPONSABILITY EXCEEDED	1746.4
95	07/23/02 13:44:03	HORSELAKE 80kV HEL 83 90k AD SHP 3812 MW		LOW RESPONSABILITY EXCEEDED	1730.7
96	07/23/02 13:44:03	HORSELAKE 120kV HEL 120kV FENG-100kV ST 1		HIGH RESPONSABILITY EXCEEDED	408.1
97	07/23/02 13:44:02	MUSKOGEE 345kV MUSK 345kV UNIT 6 MW MW		HIGH RESPONSABILITY EXCEEDED	111.1
98	07/23/02 13:44:02	HORSELAKE 80kV HEL 83 90k AD SHP 3842 MW		RETURNED TO NORMAL	1808.2
99	07/23/02 13:44:02	MTR SHP SHP SHP 1 TEST FCST1 8 MW		RETURNED TO NORMAL	118.8
100	07/23/02 13:44:02	MTR SHP SHP SHP 1 TEST FCST1 6 MW		HIGH LIMIT 1 EXCEEDED	143.8

EMS alarm display

Energy control centers



Energy Control Centers

Energy Control Center (ECC):

- SCADA, EMS, operational personnel
- Eyes & hands of the power system

Supervisory control & data acquisition (SCADA):

- Supervisory control: remote control of field devices, including gen
- Data acquisition: monitoring of field conditions
- SCADA components:
 - » Master Station: System “Nerve Center” located in ECC
 - » Remote terminal units: Gathers data at substations; sends to Master Station
 - » Communications: Links Master Station with Field Devices, telemetry is done by either leased wire, PLC, microwave, or fiber optics.

Energy management system (EMS)

- Topology processor & network configurator
- State estimator and power flow model development
- Automatic generation control (AGC), Optimal power flow (OPF)
- Security assessment and alarm processing

Balancing Systems

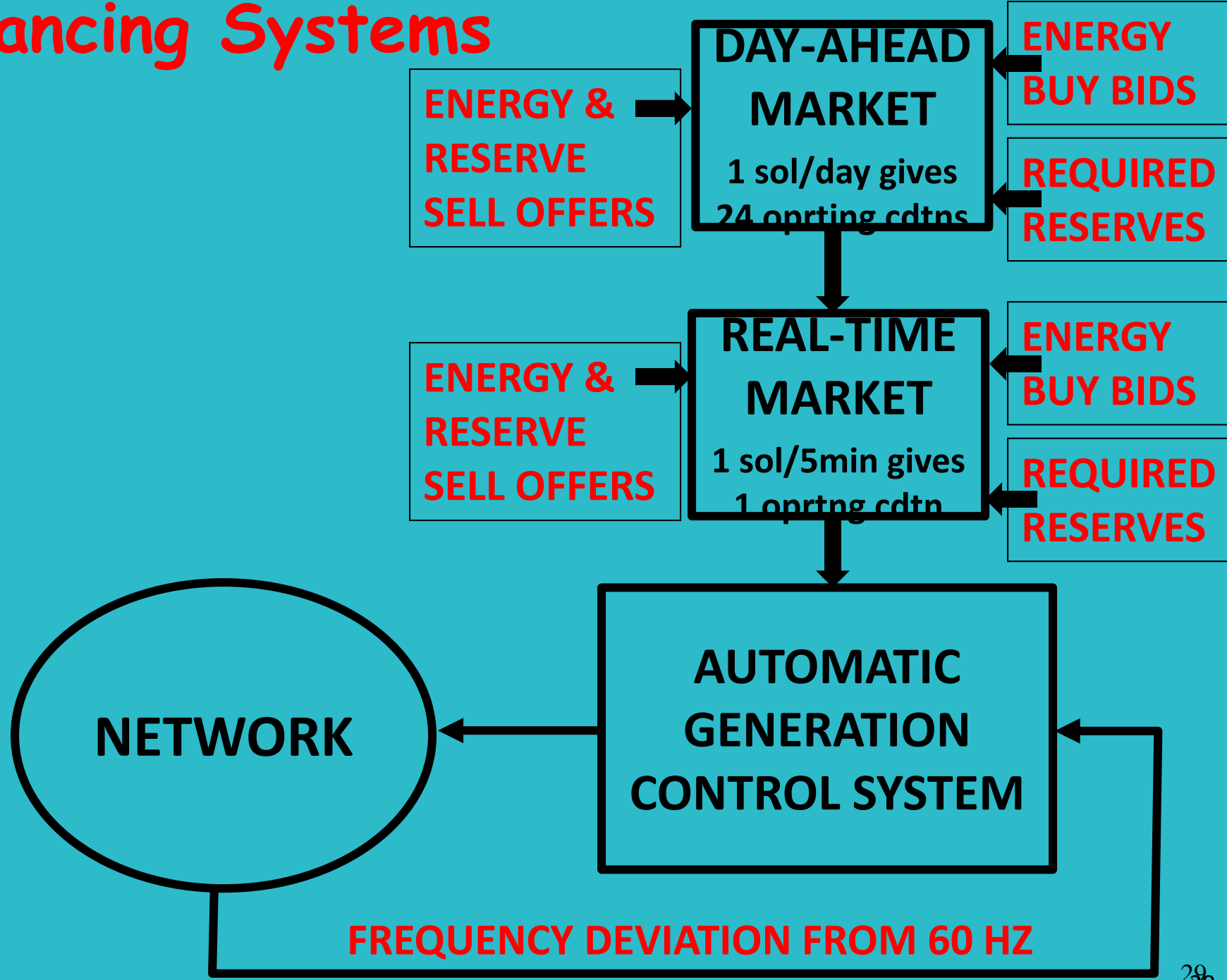

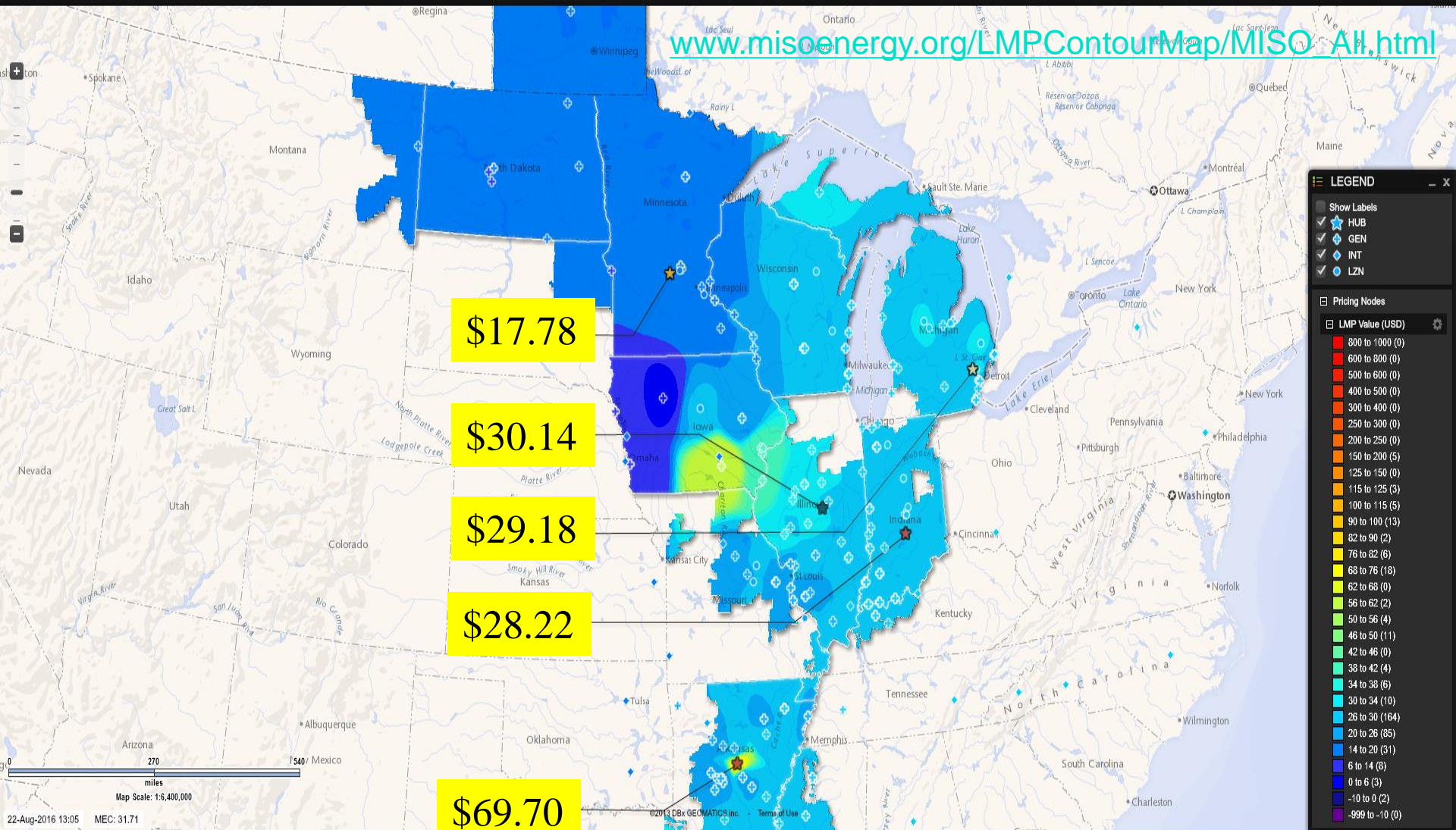

Data and prices displayed on the Midwest and South region maps and maps are preliminary representations of the entire MISO footprint. MISO makes no representations or warranties regarding the correctness or veracity of the data and prices provided on this page and shall not be responsible for any party's reliance on any such data or prices. These data and prices should not be relied upon for settlement or other purposes.

Power systems: What can go wrong?

◆ Lightning





lightning induced
flashover!

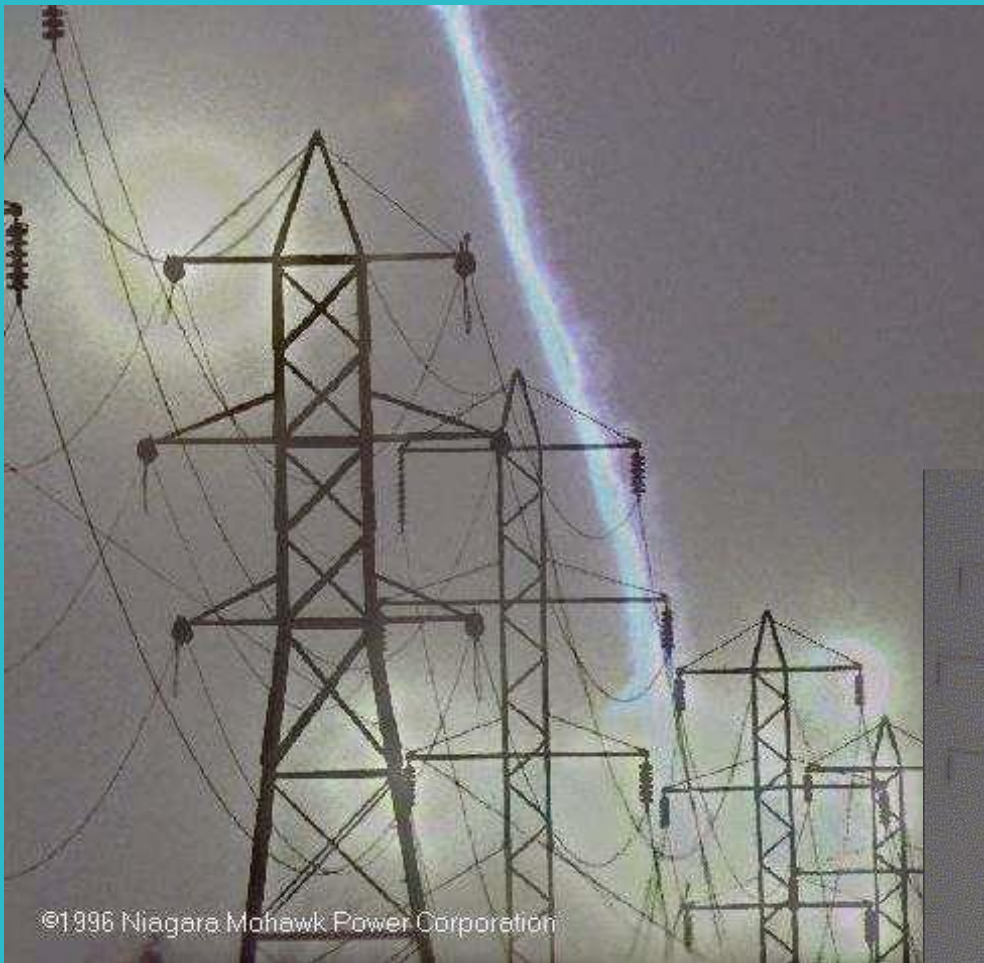

©1996 Niagara Mohawk Power Corporation



© NIAGARA MOHAWK

Power systems: What can go wrong?

- ◆ Lightning
- ◆ Natural events (wind & snow, earthquakes, wildfires...)



hurry up, I can't hold
it much longer

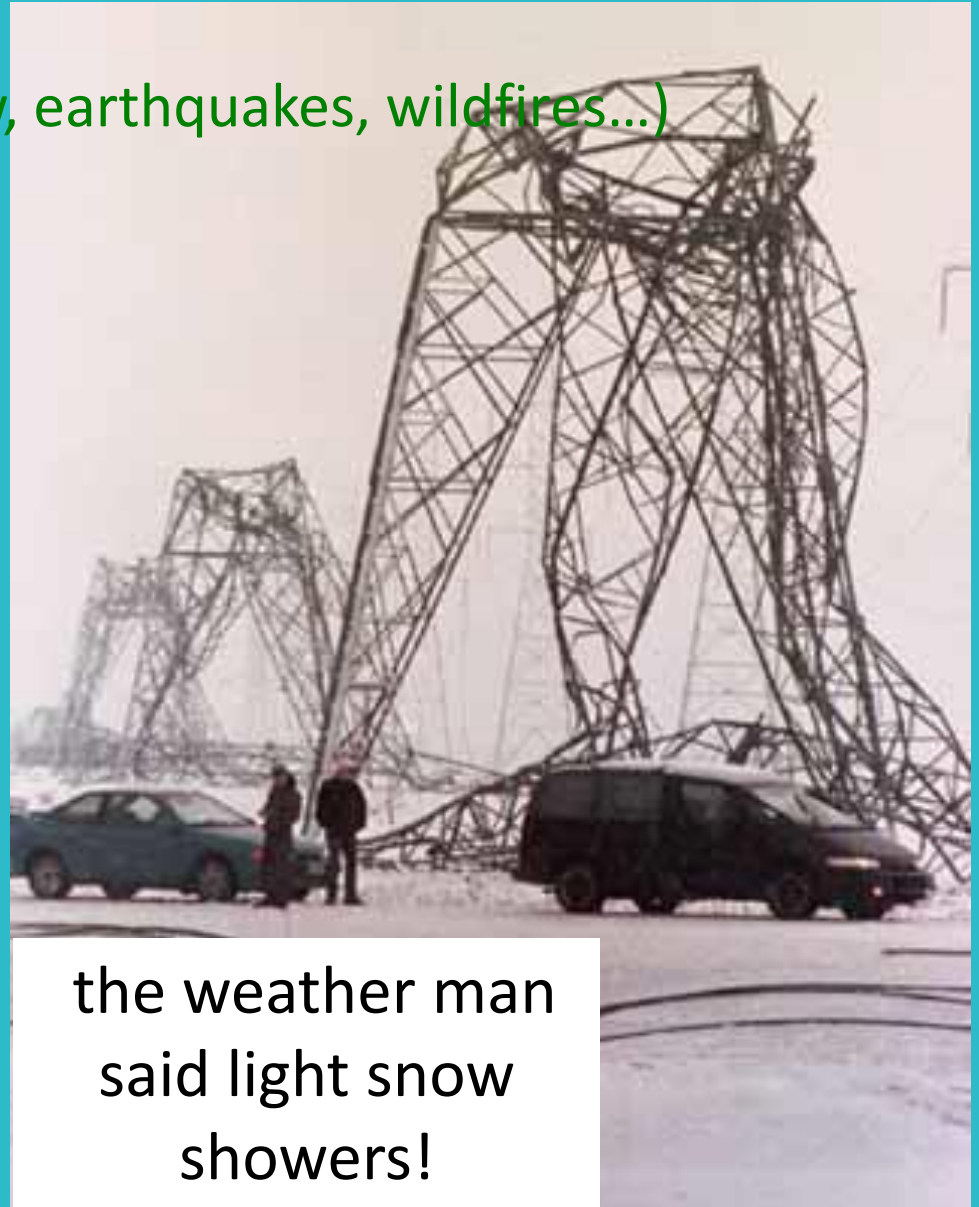

the weather man
said light snow
showers!

it was the wrong
sort of snow!

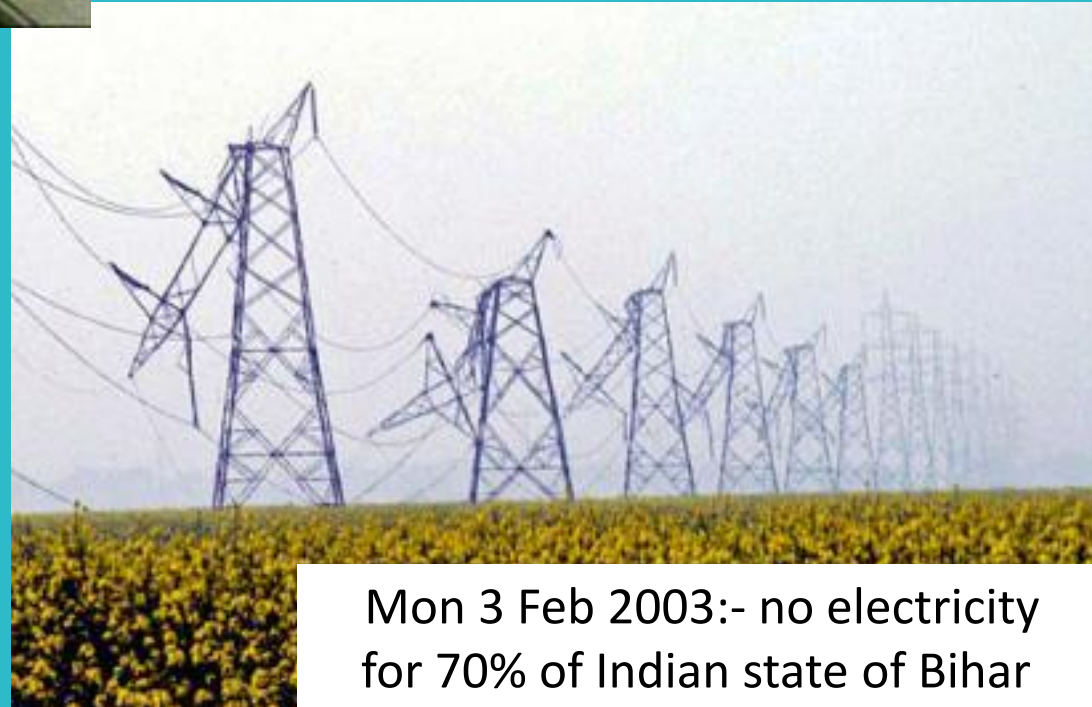

Mon 3 Feb 2003:- no electricity
for 70% of Indian state of Bihar

Power systems: What can go wrong?

- ◆ Lightning
- ◆ Natural events (wind and snow, earthquakes, wildfires...)
- ◆ Deterioration (insulation failure)





arc across 400kV insulator

Power systems: What can go wrong?

- ◆ Lightning
- ◆ Natural events (wind and snow, earthquakes, wildfires...)
- ◆ Deterioration (insulation failure)
- ◆ Animals (mainly squirrels & snakes, but sometimes....)

Time for a nap?



Power systems: What can go wrong?

- ◆ Lightning
- ◆ Natural events (wind and snow, earthquakes, wildfires...)
- ◆ Deterioration (insulation failure)
- ◆ Animals (mainly squirrels & snakes, but sometimes....)
- ◆ Vehicles and construction (accidents)

Crane contacts overhead power line during freeway construction.



46,000 volts travel through the crane and beneath the concrete road.



Power systems: What can go wrong?

- ◆ Lightning
- ◆ Natural events (wind and snow, earthquakes, wildfires...)
- ◆ Deterioration (insulation failure)
- ◆ Animals (mainly squirrels & snakes, but sometimes....)
- ◆ Vehicles and construction (accidents)
- ◆ Mistakes during maintenance



I hope you
switched it off!

Power systems: What can go wrong?

- ◆ All of the previous situations cause faults.
- ◆ Faults are dangerous situations that can hurt people and destroy equipment.
- ◆ Protection equipment removes faults:
 - Fuses detect faults and melt a wire. Must be replaced.
 - Relays detect faults and signal circuit breaker to trip.
 - Circuit breakers open lines. Can be re-used.

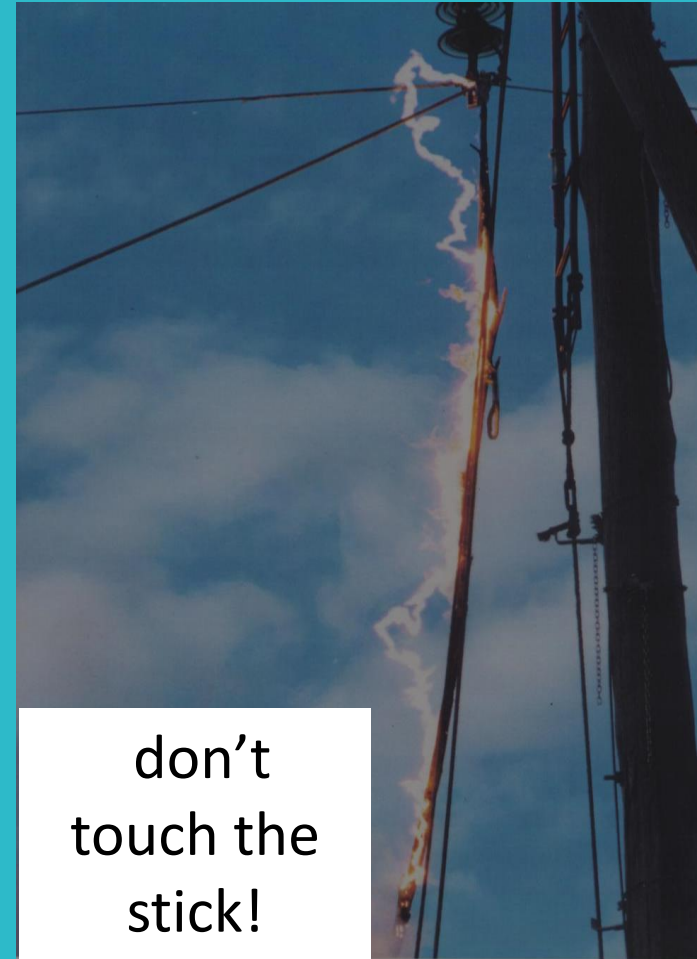

don't
touch the
stick!



Staged Faults on
400kV line



The New York Times

POWER SURGE BLACKS OUT NORTHEAST HITTING CITIES IN 8 STATES AND CANADA; MIDDAY SHUTDOWNS DISRUPT MILLIONS



In Freedom, Honor and Grief, A Powerless New York Endures

Follows Rough, Cranky System, Experts Believe

U.S. Reports Arrest of Al Qaeda Suspect For Southern Base

The Big Blackout

Blackout in America's East

The Boston Globe

Great blackout of '03

Outage hits millions in U.S., Canada

Officials find few answers but grief's fragility

New York takes chaos to stride

Tears, memories in N.H. service for slain pair

3 men arrested in second probe of 9/11 Cape killing

U.S. Reports Arrest of Al Qaeda Suspect For Southern Base

Chicago Tribune

50 million lose power

Largest blackout in history hits U.S., Canada cities

Local problem pulls plug on broad area in instant

Liberia's wait ends; U.S. troops land

Key Al Qaeda figure captured

Sky guern for other crescent with Mars

The Philadelphia Inquirer

POWERLESS

Blackout hits 50 million in U.S., Canada

NEW YORK CITY: A blackout hit U.S. cities in a first and worse of darkness

AN HOUR OF DARKNESS: Blackouts affected power stations, Chicago, which is a railroad town, came to an abrupt halt

NEW YORK STATE: Gridlock in a major thoroughfare of Manhattan

PHILADELPHIA: A 20-minute delay in a game between the Phillies and the Yankees

IN WASHINGTON: A power outage in the White House

THE NEW YORK STOCK EXCHANGE: A 15-minute delay in trading

THE NEW YORK CITY POLICE DEPARTMENT: A 15-minute delay in a game between the Yankees and the Phillies

DAILY NEWS

NEW YORK'S HOMETOWN NEWSPAPER



BLACKOUT

50 MILLION LOSE POWER

CITY SWELTERS TO A HALT

RUSH-HOUR CHAOS TODAY

LIVE FROM NEW YORK CITY



BREAKING NEWS

VOICE OF DARYN KAGAN NEW YORK

5:40p ET

TRAFFIC RUNNING SMOOTHLY; PEDESTRIANS CALMLY DISPERSED

NEW YORK POST

SPECIAL EDITION

PARALYZED



NY'ers stranded by huge blackout

1,000 252-2876

CALL TODAY 252-2876

Blackouts

Summary of well-known blackouts

Location	Date	Scale in term of MW or Population	Collapse time
US-NE[1]	10-11/9/65	20,000 MW, 30M people	13 mins
New York[2]	7/13/77	6,000 MW, 9M people	1 hour
France[3]	1978	29,000 MW	26 mins
Japan[4]	1987	8,200 MW	20mins
US-West[5]	1/17/94	7,500 MW	1 min
US-West[5]	12/14/94	9,300 MW	
US-West[5]	7/2/96	11,700 MW	36 seconds
US-West[5]	7/3/96	1,200 MW	> 1 min
US-West[5]	8/10/96	30,500 MW	> 6 mins
Brazil[6]	3/11/99	25,000 MW	30 secs
US-NE[7]	8/14/03	62,000 MW, 50M people	> 1 hour
London[8]	8/28/03	724 MW, 476K people	8 secs
Denmark & Sweden [9][10]	9/23/03	4.85M people	7mins
Italy[11]	9/28/03	27,700 MW, 57M people	27mins

1. 12:05
2. 1:14
3. 1:31
4. 2:02
5. 3:05
6. 3:32
7. 3:41
8. 3:45
9. 4:05

Conesville Unit 5 (rating 375 MW)
 Greenwood Unit 1 (rating 785 MW)
 Eastlake Unit 5 (rating: 597 MW)

Stuart – Atlanta 345 kV
 Harding-Chamberlain 345 kV
 Hanna-Juniper 345 kV
 Star-South Canton 345 kV
 Canton Central-Tidd 345 kV
 Sammis-Star 345 kV

**INITIATING
EVENT**

**SLOW
PROGRESSION**

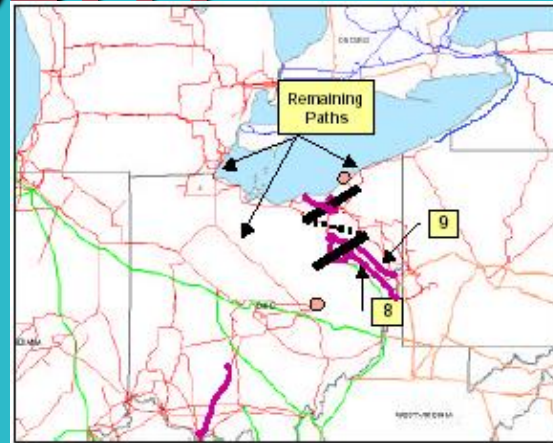
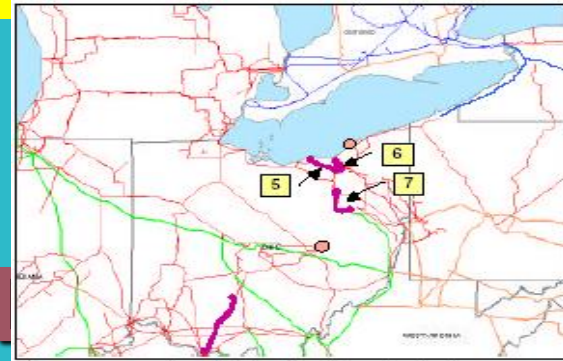
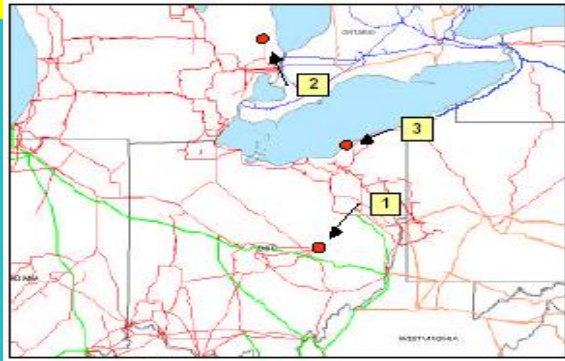

**PPENEI
AUGUST 14, 2003???**

1. 12:05	Conesville Unit 5 (rating 375 MW)	INITIATING EVENT
2. 1:14	Greenwood Unit 1 (rating 785 MW)	
3. 1:31	Eastlake Unit 5 (rating: 597 MW)	
4. 2:02	Stuart – Atlanta 345 kV	SLOW PROGRESSION
5. 3:05	Harding-Chamberlain 345 kV	
6. 3:32	Hanna-Juniper 345 kV	
7. 3:41	Star-South Canton 345 kV	
8. 3:45	Canton Central-Tidd 345 kV	
9. 4:05	Sammis-Star 345 kV	
10. 4:08:58	Galion-Ohio Central-Muskingum 345 kV	FAST PROGRESSION (cascade)
11. 4:09:06	East Lima-Fostoria Central 345 kV	
12. 4:09:23-4:10:27	Kinder Morgan (rating: 500 MW; loaded to 200 MW)	
13. 4:10	Harding-Fox 345 kV	
14. 4:10:04 – 4:10:45	20 generators along Lake Erie in north Ohio, 2174 MW	
15. 4:10:37	West-East Michigan 345 kV	
16. 4:10:38	Midland Cogeneration Venture, 1265 MW	
17. 4:10:38	Transmission system separates northwest of De	
18. 4:10:38	Perry-Ashtabula-Erie West 345 kV	
19. 4:10:40 – 4:10:44	4 lines disconnect between Pennsylvania & New York	
20. 4:10:41	2 lines disconnect and 2 gens trip in north Ohio, 1868MW	
21. 4:10:42 – 4:10:45	3 lines disconnect in north Ontario, New Jersey, isolates NE part of Eastern Interconnection, 1 unit trips, 820 mw	
22. 4:10:46 – 4:10:55	New York splits east-to-west. New England and Maritimes separate from New York and remain intact.	
23. 4:10:50 – 4:11:57	Ontario separates from NY w. of Niagara Falls & w. of St. Law. SW Connecticut separates from New York, blacks out.	

Immediate causes of the 8/14/03 blackout

- 1:30 Loss of East Lake generator (over-excitation)
- 2:02 Loss of Stuart-Atlanta (tree contact)
- 2:02 MISO system model becomes inaccurate
- 2:14-3:08 Loss of software in FE control center
- 3:05 Loss of Harding-Chamberlain (tree contact)
- 3:32 Loss of Hanna-Juniper (tree contact)
- 3:41 Loss of Star-S.Canton (tree contact)
- 4:06 Loss of Sammis-Star (high overload looked like fault to “zone 3” of the protection system)

Why so much tree-contact?

- ◆ Trees were overgrown because right-of-ways had not been properly maintained.
- ◆ Lines expand and sag due to heat; more prone in summer with high temperature & low winds; more prone with high current.
- ◆ Each successive line trip requires that the power it was carrying be transferred to flow elsewhere, resulting in increased power on remaining lines.

Figure 5.10. Cause of the Hanna-Juniper Line Loss



This August 14 photo shows the tree that caused the loss of the Hanna-Juniper line (tallest tree in photo). Other 345-kV conductors and shield wires can be seen in the background. Photo by Nelson Tree.

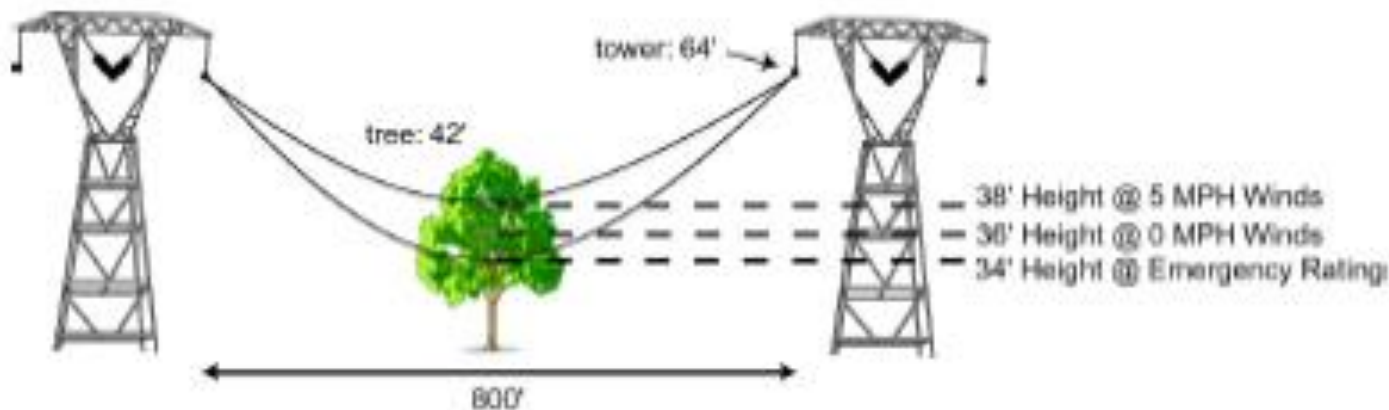

Another influence: insufficient reactive power

Another contribution to the blackout was insufficient reactive power in the Cleveland area, i.e., the reactive power (vars) in the Cleveland area generation was insufficient to meet the reactive power demand of its motors. Conditions that make a system prone to this include:

- ◆ High load, especially induction motors (air conditioners)
- ◆ Loss of generation in load-intensive area and/or loss of transmission into that load-intensive area

This results in voltage decline in the load-intensive area, and because $P \sim VI$, when voltage V declines, current I must increase in order to maintain the same power P .

When I goes up, lines load up more heavily.

Another influence: insufficient reactive power

Figure 5.6. Voltages on FirstEnergy's 345-kV Lines: Impacts of Line Trips

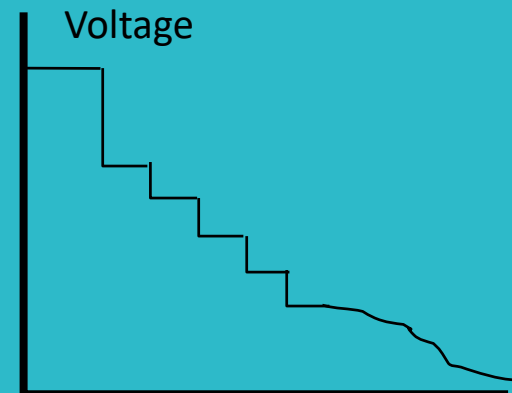
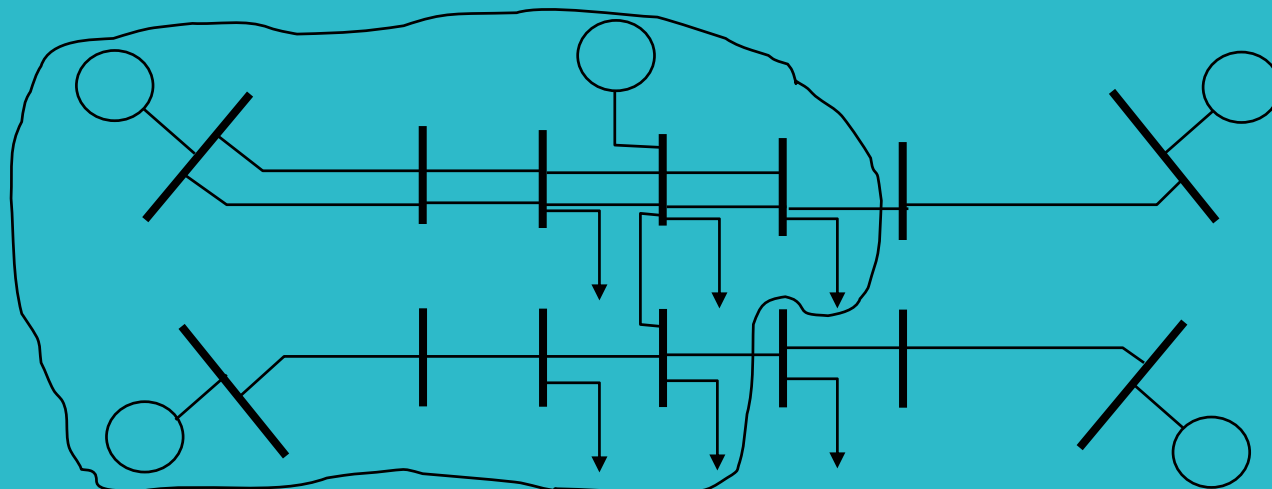
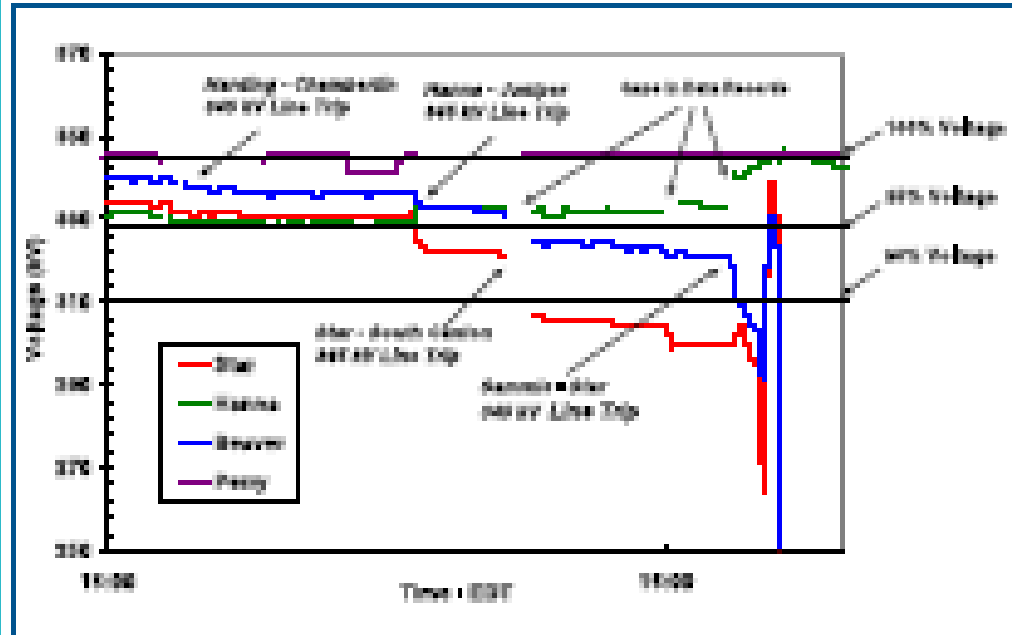

Another influence: Backup protection

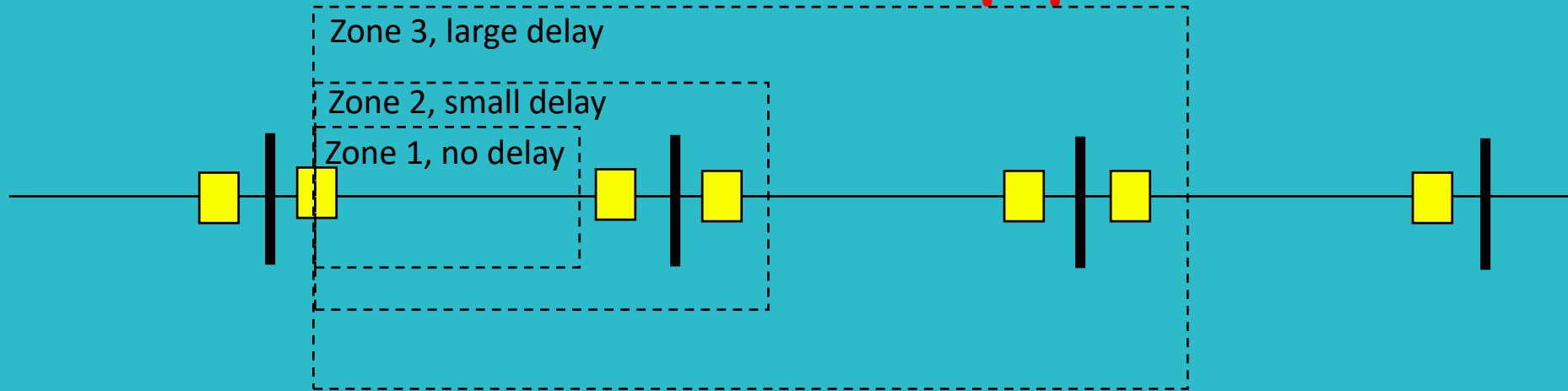

- ◆ Relays sense V/I and trip if it is too low; good approach because fault conditions are low voltage, high current.
- ◆ Relays are directional; trip only for faults “looking” in one direction.
- ◆ Zone 1 trips instantly; trip zone for primary protection
- ◆ Zone 2 has small delay. Zone 3 has large delay; these are trip zones for “backup” protection

Why did the cascade happen (events 10-23)

◆ Oscillations in voltages and currents, and/or very high currents caused many transmission line zone 2,3 protection systems to see what appeared to be faults & trip the line.

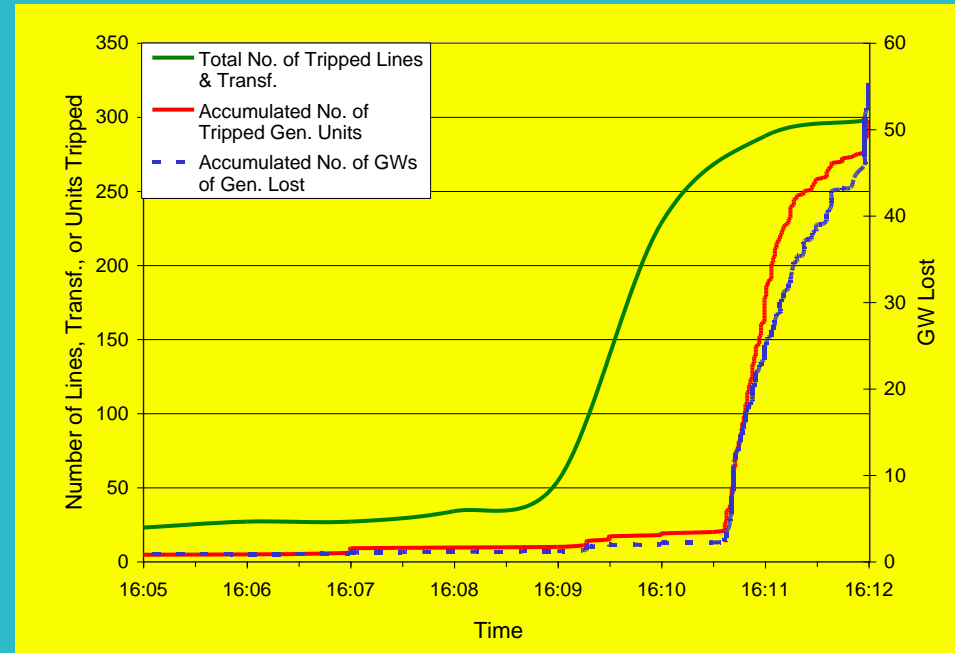

◆ As a few generators tripped, load > gen imbalance caused underfrequency and lower voltages.

◆ Generators tripped for 1 of following reasons:

- ◆ Underfrequency
- ◆ Under-voltage
- ◆ Overexcitation
- ◆ Out-of-step
- ◆ Over-voltage

Units tripped and areas outaged



The blackout outaged parts of 8 states & Ontario.

The blackout shut down 263 power plants (531 units)

Total cost: ~10 billion \$.

Half of DOE annual budget

Twice NSF annual budget

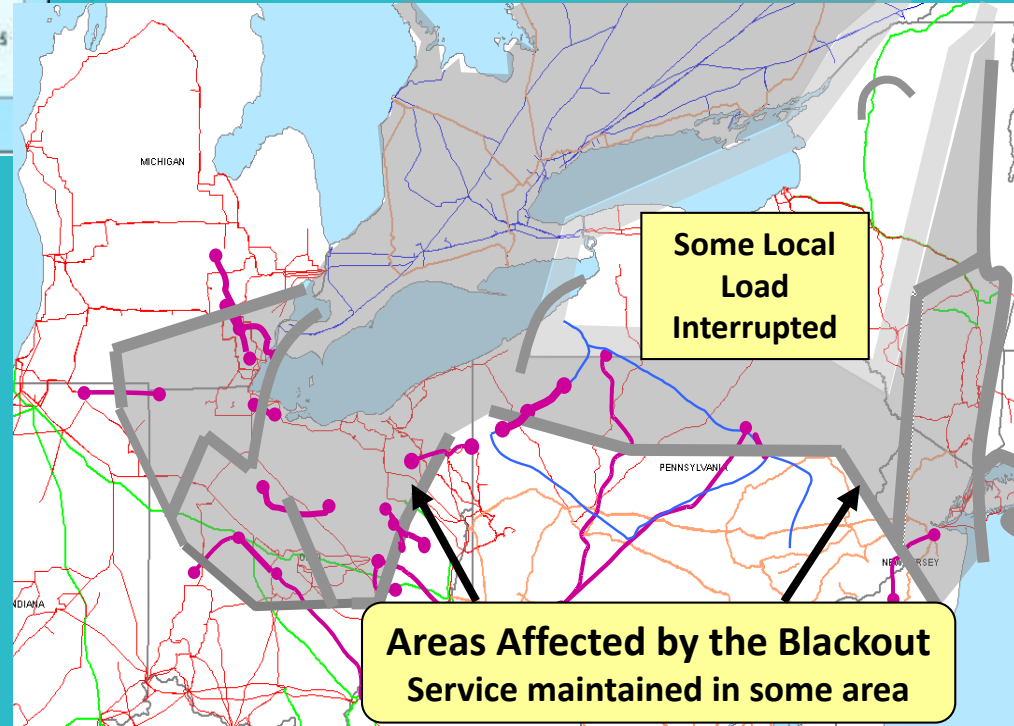

Final List of Main Causes

- ◆ There was inadequate situational awareness at First Energy (FE). FE did not recognize/understand the deteriorating condition of its system.
- ◆ FE failed to adequately manage tree growth in its transmission rights-of-way.
- ◆ Failure of the interconnected grid's reliability organizations (mainly MISO) to provide effective real-time diagnostic support.
- ◆ FE and ECAR failed to assess and understand the inadequacies of FE's system, particularly with respect to voltage instability and the vulnerability of the Cleveland-Akron area, and FE did not operate its system with appropriate voltage criteria.
 - No long-term planning studies w/ multiple contingencies or extreme conditions
 - No voltage analyses for Ohio area and inappropriate operational voltage criteria
 - No independent review or analysis of FE's voltage criteria and operating needs
 - Some of NERC's planning & operational requirements were ambiguous

A few of the 46 Recommendations

1. Make reliability standards mandatory and enforceable, with penalties for noncompliance.
2. Develop a regulator-approved funding mechanism for NERC and the regional reliability councils, to ensure their independence from the parties they oversee.
3. Strengthen the institutional framework for reliability management in North America.
4. Clarify that prudent expenditures and investments for bulk system reliability (including investments in new technologies) will be recoverable through transmission rates.
8. Shield operators who initiate load shedding pursuant to approved guidelines from liability or retaliation.
11. Establish requirements for collection and reporting of data needed for post-blackout analyses.
12. Commission an independent study of the relationships among industry restructuring, competition, and reliability.
13. DOE should expand its research programs on reliability-related tools and technologies.
16. Establish enforceable standards for maintenance of electrical clearances in right-of-way areas.
19. Improve near-term and long-term training and certification requirements for operators, reliability coordinators, and operator support staff.
21. Make more effective and wider use of system protection measures.
23. Strengthen reactive power and voltage control practices in all NERC regions.
24. Improve quality of system modeling data and data exchange practices.
26. Tighten communications protocols, especially for communications during alerts and emergencies. Upgrade communication system hardware where appropriate.
33. Develop and deploy IT management procedures.